

Boletín de la

SOCIEDAD MATEMÁTICA MEXICANA

Tercera Serie

Volumen 15

Número 2

Octubre de 2009

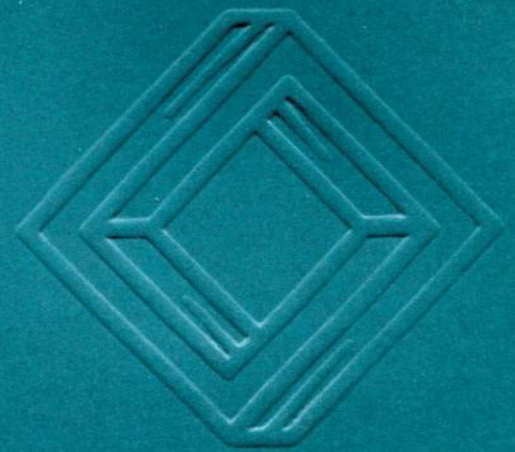

Contenido

ARTÍCULOS DE INVESTIGACIÓN

The necessary and sufficient condition for the solvability of the Diophantine matrix equation $A^{mx} + A^{my} + A^{mz} = A^{mw}$

A. Grytczuk and I. Kurzydło 109

Reproducing kernels of weighted poly-Bergman spaces on the upper half plane II

J. Ramírez Ortega 117

An optimal control problem on the Lie group $SE(2, \mathbb{R}) \times SO(2)$

A. Aron, C. Pop, and M. Puta 129

A trigonometric-hyperbolic functional equation and its application

J. Y. Chung 141

Orthogonal polynomials on rays: Christoffel's formula

A. E. Choque Rivero and S. M. Zagorodnyuk 149

Rotundity and connectedness in two dimensions

F. J. García-Pacheco 165

The spectral mapping formula in Arens-Michael-Fréchet algebras

A. Velázquez González 175

Random solution of nonlinear random multivalued operator inclusion

I. Beg and M. Abbas 179

Continúa/Continued on back cover

SOCIEDAD
MATEMÁTICA
MEXICANA



THE NECESSARY AND SUFFICIENT CONDITION FOR THE SOLVABILITY OF THE DIOPHANTINE MATRIX EQUATION

$$A^{mx} + A^{my} + A^{mz} = A^{mw}$$

ALEKSANDER GRZYTCZUK AND IZABELA KURZYDŁO

ABSTRACT. Let A be an integral 2×2 matrix. The equation

$$A^{mx} + A^{my} + A^{mz} = A^{mw}$$

has a solution in positive integers $x, y, z, w, m > 2$, where x, y, z, w are distinct, if and only if the matrix A is nilpotent or $(\det A = 0$ and $\text{Tr } A = -1)$ or $(\det A = 1$ and $\text{Tr } A = 0)$ or $(\det A = 1$ and $\text{Tr } A = -2)$ or $\det A = \text{Tr } A = 1$.

1. Introduction

We give necessary and sufficient conditions for the solvability of the matrix equation

$$(1.1) \quad A^{mx} + A^{my} + A^{mz} = A^{mw}$$

in positive, distinct integers x, y, z, w and $m > 2$. The result is an extension of earlier results contained in the papers [5], [9], [11], [12].

D. Frejman in [5] and A. Grytczuk in [9] independently proved that if $A = \begin{pmatrix} a & b \\ c & d \end{pmatrix}$, then the equation

$$(1.2) \quad A^{mx} + A^{my} = A^{mz},$$

where $x, y, z, m \in \mathbb{N}$ and $m > 2$ has no solution. In [11] Le and Li proved that if $A = \begin{pmatrix} a & b \\ c & d \end{pmatrix}$ is an integral 2×2 matrix, $a + d > 0$ and $bc > ad$, then the equation (1.2) is not satisfied in natural numbers x, y, z and $m > 2$. They posed also the conjecture that the equation (1.2), where A is an integral 2×2 matrix, has solutions in positive integers x, y, z and $m > 2$ if and only if the matrix A is a nilpotent matrix. In [12] they proved a corrected version of this conjecture: if A is an integral 2×2 matrix, then (1.2) is satisfied in positive integers x, y, z and $m > 2$ if and only if A is a nilpotent matrix or $\text{Tr } A = \det A = 1$. Another proof of this result gave A. Grytczuk in [8]. In [7] A. Grytczuk and J. Grytczuk found necessary and sufficient conditions for $A \in M_n(\mathbb{Z})$, $n \geq 2$ to satisfy the equation $A^x + A^y = A^z$ for some positive integers x, y, z .

We note that for $X = A^x, Y = A^y, Z = A^z$ we obtain from (1.2) the Fermat's equation

$$(1.3) \quad X^m + Y^m = Z^m.$$

In 1966 R. Z. Domiaty [4] discovered that the equation (1.3) has infinitely many solutions in $M_2(\mathbb{Z})$ for $m = 4$. Some results relating to the equation of Fermat

2000 Mathematics Subject Classification: 15A24,15A42.

Keywords and phrases: matrix equations, Fermat's type equation on matrices, Schur's Lemma. This paper is partly supported by EFS (European Social Funds).

in the set of matrices have been described by P. Ribenboim in monograph [15]. In 1995 A. Wiles [18], R. Taylor and A. Wiles [16] proved that (1.3) has no solutions in nonzero integers X, Y, Z if $m > 2$. An important problem is to give a necessary and sufficient condition for solvability the equation (1.3) in the set of matrices. The solvability of (1.3) in $\text{GL}_2(\mathbb{Z})$ was first investigated by L. N. Vaserstein [17]. A. Khazanov in cite10 gave necessary and sufficient conditions for solvability (1.3) for X, Y, Z belonging to $\text{SL}_2(\mathbb{Z}), \text{SL}_3(\mathbb{Z}), \text{GL}_3(\mathbb{Z})$. A. Gryczuk [9] proved some necessary condition to satisfy (1.3) in integral 2×2 matrices X, Y, Z , and in [6] he gave an extension of this result. Studies connected with Khazanov's results effected too H. Qin [14]. The equation of Fermat was investigated by Z. Cao and A. Grytczuk in [2]. In [3] Z. Cao and A. Grytczuk gave a necessary and sufficient condition for the solvability (1.3) for $X, Y, Z \in \text{SL}_2(\overline{\mathbb{Z}})$. Z. Patay and A. Szakacs [13] studied the Fermat's equation (1.3) in $\text{SL}_3(\mathbb{Z})$ and in irreducible elements of the rings $M_2(\mathbb{Z})$ and $M_3(\mathbb{Z})$.

2. Basic Lemma

LEMMA (2.1) (Schur [1]). *Let A be an $n \times n$ complex matrix. Then there is a unitary matrix P such that*

$$P^*AP = \begin{pmatrix} \lambda_1 & b_{12} & \dots & b_{1n} \\ & \lambda_2 & & \vdots \\ & & \ddots & \\ 0 & & & \lambda_n \end{pmatrix}$$

where $\lambda_1, \lambda_2, \dots, \lambda_n$ are eigenvalues of the matrix A .

3. Results

THEOREM (3.1). *Let A be an integral 2×2 matrix. The equation (1.1) has a solution in positive integers x, y, z, w and $m > 2$, where x, y, z, w are distinct, if and only if the matrix A is nilpotent or ($\det A = 0$ and $\text{Tr } A = -1$) or ($\det A = 1$ and $\text{Tr } A = 0$) or ($\det A = 1$ and $\text{Tr } A = -2$) or $\det A = \text{Tr } A = 1$.*

Proof. Suppose that the equation (1.1) holds. If A is a nilpotent matrix, then $A^k = 0$ for all $k \in \mathbb{N}, k \geq 2$. Thus (1.1) is satisfied in this case.

Suppose that A is not nilpotent.

Let $r = \text{Tr } A, s = -\det A$. Then $f(\lambda) = \lambda^2 - r\lambda - s$ is the characteristic polynomial of the matrix A and

$$(3.2) \quad \lambda_1 = \frac{r + \sqrt{r^2 + ks}}{2}, \quad \lambda_2 = \frac{r - \sqrt{r^2 + ks}}{2}$$

are eigenvalues of A .

By Lemma (2.1) there exist a unitary matrix P such that

$$(3.3) \quad A = P^*TP,$$

where T is the upper triangular matrix with the eigenvalues of the matrix A on main diagonal.

From (3.3) by induction for $k \in \mathbb{N}$ we obtain

$$(3.4) \quad A^k = P^*T^kP,$$

where T^k is the upper triangular matrix which has on main diagonal characteristic roots λ_1^k, λ_2^k .

From (1.1) and (3.4) we get

$$(3.5) \quad T^{mx} + T^{my} + T^{mz} = T^{mw}.$$

Comparing the elements on the main diagonals we obtain from (3.5)

$$(3.6) \quad \lambda_1^{mx} + \lambda_1^{my} + \lambda_1^{mz} = \lambda_1^{mw},$$

$$(3.7) \quad \lambda_2^{mx} + \lambda_2^{my} + \lambda_2^{mz} = \lambda_2^{mw}.$$

Now, we assume that $s = 0$. From (3.2) we have $\lambda_1 = \frac{r+|r|}{2}, \lambda_2 = \frac{r-|r|}{2}$. If $r > 0$, then $\lambda_1 = r$ and the equation (3.6) is not satisfied. If $r < 0$, then $\lambda_1 = 0, \lambda_2 = r$. Thus (3.6) holds for $x, y, z, w, m \in N$ and $m > 2$. Analysing the equation (3.7) we obtain that it is satisfied for $r = -1$ if and only if

(3.8)

$$mx = 2k_1, my = 2k_2, mw = 2k_3, mz = 2k_4 + 1 \text{ or}$$

$$mx = 2k_1, mz = 2k_2, mw = 2k_3, my = 2k_4 + 1 \text{ or}$$

$$my = 2k_1, mz = 2k_2, mw = 2k_3, mx = 2k_4 + 1 \text{ or}$$

$$mx = 2k_1, my = 2k_2 + 1, mz = 2k_3 + 1, mw = 2k_4 + 1 \text{ or}$$

$$my = 2k_1, mx = 2k_2 + 1, mz = 2k_3 + 1, mw = 2k_4 + 1 \text{ or}$$

$$mz = 2k_1, mx = 2k_2 + 1, my = 2k_3 + 1, mw = 2k_4 + 1, k_1, k_2, k_3, k_4 \in N.$$

Let $s \neq 0$. Then the matrix A is nonsingular. Let $u = \min\{x, y, z, w\}$. Since x, y, z, w are distinct, then by (1.1) follows that

$$(3.9) \quad A^{um} = \delta_1 A^{n_1 m} + \delta_2 A^{n_2 m} + \delta_3 A^{n_3 m}, \delta_1, \delta_2, \delta_3 \in \{-1, 1\},$$

where $u < n_1 < n_2 < n_3$.

From (3.9) we give

$$(3.10) \quad A^{m(n_1-u)}(\delta_1 I + \delta_2 A^{m(n_2-n_1)} + \delta_3 A^{m(n_3-n_1)}) = I.$$

From (3.10) we have

$$(3.11) \quad (\det A)^{m(n_1-u)} \det(\delta_1 I + \delta_2 A^{m(n_2-n_1)} + \delta_3 A^{m(n_3-n_1)}) = 1.$$

Denote $B = \delta_1 I + \delta_2 A^{m(n_2-n_1)} + \delta_3 A^{m(n_3-n_1)}$. Since A, B are integral matrices, then $\det A, \det B$ are integers. Thus by (3.11) follows that $\det A = \pm 1$. So $s = \pm 1$.

We consider the following ten cases.

1. $r = 0$ and $s = 1$.

From (3.2) we have $\lambda_1 = 1$. Then the equation (3.6) does not hold.

2. $r > 0$ and $s = 1$.

Then

$$(3.12) \quad \lambda_1 \geq \frac{1 + \sqrt{5}}{2} > \frac{3}{2}.$$

By (3.6) we have

$$(3.13) \quad \lambda_1^{m(x-w)} + \lambda_1^{m(y-w)} + \lambda_1^{m(z-w)} = 1.$$

By (3.12) and (3.13) follows that exponents $m(x-w)$, $m(y-w)$, $m(z-w)$ must be negative. The equation (3.13) is not satisfied if all indices are ≤ -3 . Therefore at least one of them must be equal to -1 or -2 , which is impossible, because x, y, z, w and $m > 2$ are natural numbers.

3. $r < 0$ and $s = 1$

Then $\lambda_2 \leq -\frac{1+\sqrt{5}}{2}$, thus $|\lambda_2| \geq \frac{1+\sqrt{5}}{2}$. Hence

$$(3.14) \quad |\lambda_2|^2 \geq |\lambda_2| + 1.$$

From (3.14) we obtain

$$(3.15) \quad |\lambda_2|^3 \geq |\lambda_2|^2 + |\lambda_2|.$$

Therefore from (3.14) and (3.15) we get

$$(3.16) \quad |\lambda_2|^3 \geq 2|\lambda_2| + 1.$$

Let $\max\{x, y, z, w\} = v$. Then by (3.7) follows that

$$\lambda_2^{mv} = \delta_1 \lambda_2^{mv_1} + \delta_2 \lambda_2^{mv_2} + \delta_3 \lambda_2^{mv_3}, \text{ where } \delta_1, \delta_2, \delta_3 \in \{-1, 1\}, v > v_1 > v_2 > v_3.$$

Hence

$$|\lambda_2|^{mv} \leq |\lambda_2|^{mv_1} + |\lambda_2|^{mv_2} + |\lambda_2|^{mv_3},$$

which implies

$$(3.17) \quad 3|\lambda_2|^{mv_1} > |\lambda_2|^{mv}.$$

From (3.17) and (3.16) we get a contradiction.

4. $r = 0$ and $s = -1$.

From (3.2) we have $\lambda_1 = \sqrt{-1}$, $\lambda_2 = -\sqrt{-1}$. By an easy calculation we obtain

$$(3.18) \quad \lambda_1^{mw} = \begin{cases} 1 & \text{if } mw = 4k \\ \sqrt{-1} & \text{if } mw = 4k + 1 \\ [1pt] - 1 & \text{if } mw = 4k + 2 \\ -\sqrt{-1} & \text{if } mw = 4k + 3 \end{cases}, \quad k \in N \cup \{0\}$$

$$(3.19) \quad \lambda_2^{mw} = \begin{cases} 1 & \text{if } mw = 4k \\ -\sqrt{-1} & \text{if } mw = 4k + 1 \\ -1 & \text{if } mw = 4k + 2 \\ \sqrt{-1} & \text{if } mw = 4k + 3 \end{cases}, \quad k \in N \cup \{0\}.$$

From (3.18), (3.19), (3.6), (3.7) we observe that the equation (1.1) is satisfied if and only if the following relations are satisfied

$$(3.20) \quad \begin{aligned} mx &\equiv r_1 \pmod{4}, my \equiv r_2 \pmod{4}, mz \equiv r_3 \pmod{4}, mw \equiv r_4 \pmod{4}, \\ (r_1, r_2, r_3, r_4) &= \langle 0, 0, 2, 0 \rangle, \langle 2, 0, 0, 0 \rangle, \langle 0, 2, 0, 0 \rangle, \langle 1, 1, 3, 1 \rangle, \\ &\langle 3, 1, 1, 1 \rangle, \langle 1, 3, 1, 1 \rangle, \langle 2, 2, 0, 2 \rangle, \langle 2, 0, 2, 2 \rangle, \langle 0, 2, 2, 2 \rangle, \langle 3, 3, 1, 3 \rangle, \\ &\langle 1, 3, 3, 3 \rangle, \langle 3, 1, 3, 3 \rangle, \langle 0, 1, 2, 1 \rangle, \langle 0, 2, 1, 1 \rangle, \langle 1, 0, 2, 1 \rangle, \langle 1, 2, 0, 1 \rangle, \\ &\langle 2, 0, 1, 1 \rangle, \langle 2, 1, 0, 1 \rangle, \langle 0, 2, 3, 3 \rangle, \langle 0, 3, 2, 3 \rangle, \langle 2, 0, 3, 3 \rangle, \langle 2, 3, 0, 3 \rangle, \\ &\langle 3, 0, 2, 3 \rangle, \langle 3, 2, 0, 3 \rangle, \langle 1, 3, 0, 0 \rangle, \langle 1, 0, 3, 0 \rangle, \langle 0, 1, 3, 0 \rangle, \langle 0, 3, 1, 0 \rangle, \\ &\langle 3, 0, 1, 0 \rangle, \langle 3, 1, 0, 0 \rangle, \langle 1, 3, 2, 2 \rangle, \langle 1, 2, 3, 2 \rangle, \langle 2, 1, 3, 2 \rangle, \langle 2, 3, 1, 2 \rangle, \\ &\langle 3, 1, 2, 2 \rangle, \langle 3, 2, 1, 2 \rangle. \end{aligned}$$

5. $r = 2$ and $s = -1$.

Then $\lambda_1 = 1$ and (3.6) is impossible.

6. $r = -2$ and $s = -1$.

Then $\lambda_1 = -1$ and from (3.6) we obtain the equation

$$(-1)^{mx} + (-1)^{my} + (-1)^{mz} = (-1)^{mw},$$

which holds if and only if (3.8).

7. $r \leq -3$ and $s = -1$.

Then $|\lambda_1| \geq \frac{3-\sqrt{5}}{2}$, $|\lambda_2| \geq \frac{3+\sqrt{5}}{2}$. Therefore $\max\{|\lambda_1|, |\lambda_2|\} = |\lambda_2| > \frac{1+\sqrt{5}}{2}$. Similarly as in case 3⁰ we obtain a contradiction.

8. $r \geq 3$ and $s = -1$.

We see that $\max\{|\lambda_1|, |\lambda_2|\} = |\lambda_1| > \frac{1+\sqrt{5}}{2}$ and we get contradiction in a similar way as in case 7⁰.

9. $r = -1$ and $s = -1$.

Then $\lambda_1 = \frac{-1+\sqrt{-3}}{2}$ and $\lambda_1^3 = 1$. Analysing the exponents mx, my, mz, mw modulo 3 in (3.6) it easy to see that (3.6) is impossible.

10. $r = 1$ and $s = -1$.

Then $\lambda_1 = \frac{1+\sqrt{-3}}{2}$, $\lambda_2 = \frac{1-\sqrt{-3}}{2}$ are eigenvalues of A . We see that

$$(3.21) \quad \lambda_1^{mw} = \begin{cases} 1 & \text{if } mw = 6k \\ \lambda_1 & \text{if } mw = 6k + 1 \\ \lambda_1^2 & \text{if } mw = 6k + 2 \\ -1 & \text{if } mw = 6k + 3 \\ -\lambda_1 & \text{if } mw = 6k + 4 \\ -\lambda_1^2 & \text{if } mw = 6k + 5 \end{cases}, \quad k \in N \cup \{0\}$$

$$(3.22) \quad \lambda_2^{mw} = \begin{cases} 1 & \text{if } mw = 6k \\ \lambda_2 & \text{if } mw = 6k + 1 \\ -\lambda_1 & \text{if } mw = 6k + 2 \\ -1 & \text{if } mw = 6k + 3 \\ -\lambda_2 & \text{if } mw = 6k + 4 \\ \lambda_1 & \text{if } mw = 6k + 5 \end{cases}, \quad k \in N \cup \{0\}$$

From (3.21), (3.22), (3.6) and (3.7) we get that (1.1) holds if and only if the following relations are satisfied

(3.23)

$$\begin{aligned}
& mx \equiv r_1 \pmod{6}, \quad my \equiv r_2 \pmod{6}, \quad mz \equiv r_3 \pmod{6}, \quad mw \equiv r_4 \pmod{6}, \\
& \langle r_1, r_2, r_3, r_4 \rangle = \langle 0, 0, 3, 0 \rangle, \langle 0, 3, 0, 0 \rangle, \langle 3, 0, 0, 0 \rangle, \langle 1, 1, 4, 1 \rangle, \langle 4, 1, 1, 1 \rangle, \langle 1, 4, 1, 1 \rangle, \\
& \langle 2, 2, 5, 2 \rangle, \langle 5, 2, 2, 2 \rangle, \langle 2, 5, 2, 2 \rangle, \langle 3, 3, 0, 3 \rangle, \langle 0, 3, 3, 3 \rangle, \langle 3, 0, 3, 3 \rangle, \langle 4, 4, 1, 4 \rangle, \\
& \langle 1, 4, 4, 4 \rangle, \langle 4, 1, 4, 4 \rangle, \langle 5, 5, 2, 5 \rangle, \langle 2, 5, 5, 5 \rangle, \langle 5, 2, 5, 5 \rangle, \langle 0, 1, 3, 1 \rangle, \langle 0, 3, 1, 1 \rangle, \\
& \langle 1, 0, 3, 1 \rangle, \langle 1, 3, 0, 1 \rangle, \langle 3, 0, 1, 1 \rangle, \langle 3, 1, 0, 1 \rangle, \langle 0, 1, 4, 0 \rangle, \langle 0, 4, 1, 0 \rangle, \langle 1, 0, 4, 0 \rangle, \\
& \langle 1, 4, 0, 0 \rangle, \langle 4, 0, 1, 0 \rangle, \langle 4, 1, 0, 0 \rangle, \langle 0, 2, 3, 2 \rangle, \langle 0, 3, 2, 2 \rangle, \langle 3, 2, 0, 2 \rangle, \langle 3, 0, 2, 2 \rangle, \\
& \langle 2, 0, 3, 2 \rangle, \langle 2, 3, 0, 2 \rangle, \langle 0, 2, 5, 0 \rangle, \langle 0, 5, 2, 0 \rangle, \langle 2, 0, 5, 0 \rangle, \langle 2, 5, 0, 0 \rangle, \langle 5, 0, 2, 0 \rangle, \\
& \langle 5, 2, 0, 0 \rangle, \langle 0, 3, 4, 4 \rangle, \langle 0, 4, 3, 4 \rangle, \langle 3, 0, 4, 4 \rangle, \langle 3, 4, 0, 4 \rangle, \langle 4, 0, 3, 4 \rangle, \langle 4, 3, 0, 4 \rangle, \\
& \langle 0, 3, 5, 5 \rangle, \langle 0, 5, 3, 5 \rangle, \langle 3, 0, 5, 0 \rangle, \langle 3, 5, 0, 0 \rangle, \langle 5, 0, 3, 5 \rangle, \langle 5, 3, 0, 5 \rangle, \langle 1, 2, 4, 2 \rangle, \\
& \langle 1, 4, 2, 2 \rangle, \langle 2, 1, 4, 2 \rangle, \langle 2, 4, 1, 2 \rangle, \langle 4, 1, 2, 2 \rangle, \langle 4, 2, 1, 2 \rangle, \langle 1, 2, 5, 1 \rangle, \langle 1, 5, 2, 1 \rangle, \\
& \langle 2, 1, 5, 1 \rangle, \langle 2, 5, 1, 1 \rangle, \langle 5, 2, 1, 1 \rangle, \langle 5, 1, 2, 1 \rangle, \langle 1, 3, 4, 3 \rangle, \langle 1, 4, 3, 3 \rangle, \langle 3, 1, 4, 3 \rangle, \\
& \langle 3, 4, 1, 3 \rangle, \langle 4, 1, 3, 3 \rangle, \langle 4, 3, 1, 3 \rangle, \langle 1, 4, 5, 5 \rangle, \langle 1, 5, 4, 5 \rangle, \langle 4, 1, 5, 5 \rangle, \langle 4, 5, 1, 5 \rangle, \\
& \langle 5, 1, 4, 5 \rangle, \langle 5, 4, 1, 5 \rangle, \langle 2, 3, 5, 3 \rangle, \langle 2, 5, 3, 3 \rangle, \langle 5, 2, 3, 3 \rangle, \langle 5, 3, 2, 3 \rangle, \langle 3, 2, 5, 3 \rangle, \\
& \langle 3, 5, 2, 3 \rangle, \langle 2, 4, 5, 4 \rangle, \langle 2, 5, 4, 4 \rangle, \langle 4, 2, 5, 4 \rangle, \langle 4, 5, 2, 4 \rangle, \langle 5, 2, 4, 4 \rangle, \langle 5, 4, 2, 4 \rangle.
\end{aligned}$$

The proof of Theorem (3.1) is complete. \square

From the proof of Theorem (3.1) we obtain the following :

THEOREM (3.24). *All solutions of the equation (1.1) in positive integers x, y, z, w and $m > 2$, where x, y, z, w are distinct, are given by*

(10) *if $(\det A = 0$ and $\text{Tr } A = -1)$ or $(\det A = 1$ and $\text{Tr } A = -2)$,*

(22) *if $(\det A = 1$ and $\text{Tr } A = 0)$,*

(25) *if $\det A = \text{Tr } A = 1$, and if A is a nilpotent matrix with nilpotency index $k \geq 2$ then (1.1) holds for all natural numbers x, y, z, w and $m > 2$ such that $mx \geq k, my \geq k, mz \geq k, mw \geq k$.*

Acknowledgment

We would like to thank the Referee for his valuable remarks and comments which allowed the improvement of our paper.

Received March 04, 2008

Final version received March 21, 2009

FACULTY OF MATHEMATICS

COMPUTER SCIENCE AND ECONOMETRICS

UNIVERSITY OF ZIELONA GÓRA

65-516 ZIELONA GÓRA

POLAND

A.Grytczuk@wmie.uz.zgora.pl AND I.Kurzydlo@wmie.uz.zgora.pl

REFERENCES

- [1] R. BELLMANN, *Wedenie v teoriju matric* (Moskva: Publishing House Science) 1976.
- [2] Z. CAO AND A. GRZYTCZUK, *Fermat's type equations in the set of 2×2 integral matrices*, Tsukuba J. Math. **22** (1998), 637–643.
- [3] Z. CAO AND A. GRZYTCZUK, *Some remarks on Fermat's equation in the set of matrices*, Acta Acad. Paed. Agriensis, Sectio Math. **27** (2000), 39–46.
- [4] R.Z. DOMIATY, *Solutions of $x^4 + y^4 = z^4$ in 2×2 integral matrices*, Amer. Math. Monthly **73** (1966), 631.
- [5] D. FREJMAN, *On Fermat's equation in the set of Fibonacci matrices*, Discuss. Math. **13** (1993), 61–63.

- [6] A. GRYTCZUK, *Fermat's equation in the set of matrices and special functions*, Studia Univ. Babeş-Bolyai, Mathematica **4** (1997), 49–55.
- [7] A. GRYTCZUK AND J. GRYTCZUK, *Ljunggren's trinomials and matrix equation $A^x + A^y = A^z$* , Tsukuba J. Math. **2** (2002), 229–235.
- [8] A. GRYTCZUK, *On a conjecture about the equation $A^{mx} + A^{my} = A^{mz}$* , Acta Acad. Paed. Agrieusis, Sectio Math. **25** (1998), 61–70.
- [9] A. GRYTCZUK, *On Fermat's equation in the set of integral 2×2 matrices*, Period. Math. Hungar. **30** (1995), 67–72.
- [10] A. KHAZANOV, *Fermat's equation in matrices*, Serodica Math. J. **21** (1995), 19–40.
- [11] M. LE AND C. LI, *A note on Fermat's equation in integral 2×2 matrices*, Discuss. Math., Algebra and Stochastic Methods **15** (1995), 135–136.
- [12] M. LE AND C. LI, *On Fermat's equation in integral 2×2 matrices*, Period. Math. Hung. **31** (1995), 219–222.
- [13] Z. PATAY AND A. SZAKACS, *On Fermat's problem in matrix rings and groups*, Publ. Math. Debrecen **61** (3–4), (2002), 487–494.
- [14] H. QIN, *Fermat's problem and Goldbach problem over $M_n(\mathbb{Z})$* , Linear Algebra App. **236** (1996), 131–135.
- [15] P. RIBENBOIM, *13 Lectures on Fermat's Last Theorem* (New York: Springer-Verlag) 1979.
- [16] R. TAYLOR AND A. WILES, *Ring-theoretic properties of certain Hecke algebras*, Anals of Math. **141** (1995), 553–572.
- [17] N. L. VASERSTEIN, *Non-commutative number theory*, Contemp. Math. **83** (1989), 445–449.
- [18] A. WILES, *Modular elliptic curres and Fermat's Last Theorem*, Anals of Math. **141** (1995), 443–551.

REPRODUCING KERNELS OF WEIGHTED POLY-BERGMAN SPACES ON THE UPPER HALF-PLANE, PART II

JOSUÉ RAMÍREZ ORTEGA

ABSTRACT. Let Π be the upper half-plane. The weighted n -poly-Bergman space of Π consists of all functions in $L^2(\Pi, (\lambda + 1)(2y)^\lambda dx dy)$ satisfying the equation $(\frac{\partial}{\partial \bar{z}})^n f = 0$. In the case $\lambda = 0$ new representations of poly-Bergman kernels are given by differentiation of certain rational functions. In general, the weighted poly-Bergman kernels are given by means of the action of a certain operator group on an orthonormal basis of $L^2(\mathbb{R}^+, dx dy)$.

1. Introduction

Using Vasilevski’s methods ([6]), formulae for weighted poly-Bergman kernels of the upper half-plane Π were obtained in [4]. For instance (see [6]), the true- n -poly-Bergman kernel of Π is given by

$$(1.1) \quad K_{(n)}(z, \zeta) = \frac{-1}{(z - \bar{\zeta})^2} \sum_{j=0}^{n-1} \sum_{k=0}^{n-1} \lambda_{jkn} \left(\frac{z - \bar{z}}{z - \bar{\zeta}} \right)^j \left(\frac{\zeta - \bar{\zeta}}{z - \bar{\zeta}} \right)^k, \quad n \geq 1$$

where

$$\lambda_{jkn} = \frac{(-1)^{j+k}}{\pi \beta(j+1, k+1)} \binom{n-1}{j} \binom{n-1}{k},$$

and $\beta(x, y)$ is the usual beta function ([5]). In Section 4 we establish a new form of the poly-Bergman kernels. We will see, for instance, that the true- n -poly-Bergman kernel is given by differentiation of the rational function

$$\frac{(\bar{z} + s)^{n-1}}{\bar{\zeta} + s} \left(\frac{\zeta + s}{\bar{\zeta} + s} \right)^{n-1}.$$

For weighted poly-Bergman spaces, reproducing kernels are given by the action of the operators

$$X_\zeta = E_t D_\tau \quad (\zeta = t + i\tau)$$

onto the Laguerre polynomials with suitable weight attached, where E_t and D_τ are defined by $(E_t f)(x) = e^{-itx} f(x)$ and $(D_\tau f)(x) = \sqrt{\tau} f(\tau x)$. We point out that the operator group $\mathcal{E}\mathcal{D} = \{X_\zeta : \zeta \in \Pi\}$ is isomorphic to the semi-direct product $\mathbb{R} \rtimes \mathbb{R}^+$ of the additive group \mathbb{R} and the multiplicative group \mathbb{R}^+ , as shown in Section 5. On the other hand the Fourier transform of $K_{(n)\lambda}(z, \zeta)$ with respect to $t = \text{Re } \zeta$ was obtained in [4] as a convolution of elements of an orthonormal basis for $L^2(\mathbb{R}^+)$. From this fact the operator group $\mathcal{E}\mathcal{D}$ comes out.

Recall that the Bergman space of a domain $G \subset \mathbb{C}$ is defined as the space of all analytic functions on G belonging to $L^2(G)$. The Bergman space is denoted

2000 Mathematics Subject Classification: 31A10, 32A36, 46E22, 47B34.

Keywords and phrases: Bergman projection, kernel operator.

by $A^2(G)$. By definition, the Bergman projection B is the orthogonal projection from $L^2(G)$ onto $A^2(G)$. The following integral representation of B is well known ([1]):

$$(Bf)(z) = \int_G K(z, \zeta) f(\zeta) d\mu(\zeta),$$

where $K(z, \zeta)$ is the Bergman kernel of G , and $d\mu(\zeta) = dt d\tau$ is the usual Lebesgue measure. For instance ([6]), the Bergman kernel for Π is given by

$$K(z, \zeta) = -\frac{1}{\pi(z - \bar{\zeta})^2}.$$

Introducing generalizations, the weighted n -poly-Bergman space $\mathcal{A}_{n\lambda}^2(\Pi)$ is the subspace of $L^2(\Pi, d\mu_\lambda)$ consisting of all (n -analytic) functions $f(z) = f(x, y)$ which satisfy the equation

$$\left(\frac{\partial}{\partial \bar{z}}\right)^n f = 0,$$

where $d\mu_\lambda(z) = (\lambda + 1)(2y)^\lambda dx dy$, and as usual $2\partial/\partial \bar{z} = \partial/\partial x + i\partial/\partial y$ ([6]). Note that $\mathcal{A}_{10}^2(\Pi)$ is the Bergman space of Π . By the Riesz representation theorem we have an integral representation for the orthogonal projection B_n from $L^2(\Pi, d\mu_\lambda)$ onto $\mathcal{A}_{n\lambda}^2(\Pi)$:

$$(B_n f)(z) = \int_\Pi f(z, \zeta) K_{n\lambda}(z, \zeta) d\mu_\lambda(\zeta),$$

where $K_{n\lambda}(z, \zeta)$ is the so-called weighted n -poly-Bergman kernel of Π ([6]).

The weighted true- n -poly-Bergman space is defined as

$$\mathcal{A}_{(n)\lambda}^2(\Pi) = \mathcal{A}_{n\lambda}^2(\Pi) \ominus \mathcal{A}_{n-1,\lambda}^2(\Pi),$$

where by convention $\mathcal{A}_{0\lambda}^2(\Pi) = \{0\}$. The weighted true- n -poly-Bergman projection $B_{(n)}$ is defined as the orthogonal projection from $L^2(\Pi, d\mu_\lambda)$ onto $\mathcal{A}_{(n)\lambda}^2(\Pi)$. Obviously

$$B_n = \sum_{k=1}^n B_{(k)}.$$

The n -anti-analytic and true- n -anti-analytic function spaces $\tilde{\mathcal{A}}_{n\lambda}^2(\Pi)$ and $\tilde{\mathcal{A}}_{(n)\lambda}^2(\Pi)$ are defined along the same lines, with $\partial/\partial \bar{z}$ changed to $\partial/\partial z$. The corresponding orthogonal projections are denoted by \tilde{B}_n and $\tilde{B}_{(n)}$.

2. Bases and Isomorphisms on $L^2(\mathbb{R})$

In this section we will give orthonormal bases for $L^2(\mathbb{R})$, as well as the relationship between them, via unitary operators such as the Fourier transform, dilation and translation operators. We will express the reproducing kernels of weighted poly-Bergman spaces in terms of the action of certain operator groups on the orthonormal bases.

It is well known that the following systems of functions form orthonormal bases for $L^2(\mathbb{R})$:

$$(2.1) \quad \begin{aligned} \ell_n^\pm(y) &= (-1)^n L_n(|y|) e^{-|y|^2/2} \chi_\pm(y), \quad n \geq 0, \\ \phi_n(y) &= \frac{1}{\sqrt{2\pi}} \frac{(\phi(y))^n}{1/2 + iy}, \quad n \in \mathbb{Z}, \end{aligned}$$

where $L_n(y)$ is the Laguerre polynomial of degree n

$$L_n(y) = \sum_{k=0}^n \binom{n}{k} \frac{(-y)^k}{k!},$$

and $\phi(y)$ is a Möbius transformation defined by

$$(2.2) \quad \phi(y) = \frac{1/2 - iy}{1/2 + iy}.$$

As usual, $\Gamma(z)$ denotes the gamma function. Then for each $\text{Re } \zeta > 0$,

$$(2.3) \quad \int_0^\infty e^{-t\zeta} t^\kappa dt = \frac{\Gamma(\kappa + 1)}{\zeta^{\kappa+1}},$$

$$(2.4) \quad F^* \left(\frac{k!}{(\zeta \pm iy)^{k+1}} \right) = \sqrt{2\pi} |y|^k e^{-\zeta|y|} \chi_\pm(y),$$

where F is the Fourier transform defined by

$$(Ff)(x) = \frac{1}{\sqrt{2\pi}} \int_{\mathbb{R}} e^{-itx} f(t) dt.$$

Formulae (2.3)-(2.4) can be used to prove the following theorem.

THEOREM (2.5). ([4]) *We have*

$$\begin{aligned} (F^* \phi_n)(y) &= \ell_n^+(y), \quad n \geq 0, \\ (F^* \phi_n)(y) &= \ell_{|n|-1}^-(y), \quad n < 0. \end{aligned}$$

At first sight the system of functions (2.1) has nothing special about it other than its simplicity. Actually we can use, instead of ϕ , any Möbius transformation keeping the reals invariant. The resulting system will be an orthonormal basis, which can be obtained by means of unitary operators defined in terms of dilation and translation operators, as we will show. For $\delta > 0$, and b any real number, we will introduce three unitary operators acting on $L^2(\mathbb{R})$:

$$(2.6) \quad (D_\delta f)(y) = \sqrt{\delta} f(\delta y), \quad (E_b f)(y) = e^{-iby} f(y), \quad (T_b f)(y) = f(y - b).$$

Let ζ be a complex number such that $\text{Im } \zeta > 0$. Consider the unitary operators

$$\begin{aligned} X_\zeta &= E_{\text{Re } \zeta} D_{\text{Im } \zeta}, \\ Y_\zeta &= T_{-\text{Re } \zeta} D_{(\text{Im } \zeta)^{-1}}. \end{aligned}$$

We will use the well-known properties $FD_\delta = D_{1/\delta}F$, $FE_b = T_{-b}F$, $FT_b = E_bF$. These imply, for instance, that $FY_\zeta = X_{-\bar{\zeta}}F$, $F^2Y_\zeta = Y_{-\bar{\zeta}}F^2$, $F^2X_\zeta = X_{-\bar{\zeta}}F^2$, and

$$FX_\zeta = Y_\zeta F.$$

Since X_ζ and Y_ζ are unitary, the following systems of functions form orthonormal bases for $L^2(\mathbb{R})$:

$$(2.7) \quad \begin{aligned} \ell_{n\zeta}^\pm(y) &= (X_\zeta D_{2\ell_n^\pm})(y) = \sqrt{2\text{Im } \zeta} e^{-i\text{Re } \zeta y} \ell_n^\pm(2\text{Im } \zeta y), \quad n \geq 0, \\ \phi_{n\zeta}(y) &= (Y_\zeta D_{1/2} \phi_n)(y) = \sqrt{\frac{\text{Im } \zeta}{\pi}} \frac{(\phi_\zeta(y))^n}{i(\zeta + y)}, \quad n \in \mathbb{Z}, \end{aligned}$$

where $\phi_\zeta(y)$ is the Möbius transformation given by

$$(2.8) \quad \phi_\zeta(y) = -\frac{\zeta + y}{\bar{\zeta} + y}.$$

THEOREM (2.9). *We have*

$$\begin{aligned} (F^* \phi_{n\zeta})(y) &= \ell_{n\zeta}^+(y), \quad n \geq 0, \\ (F^* \phi_{n\zeta})(y) &= \ell_{|n|-1, \zeta}^-(y), \quad n < 0. \end{aligned}$$

COROLLARY (2.10). *If $\zeta = it$, where t is a real number, then*

$$\begin{aligned} (F^* \phi_{n,it})(y) &= \sqrt{2t} \ell_n^+(2ty), \quad n \geq 0, \\ (F^* \phi_{n,it})(y) &= \sqrt{2t} \ell_{|n|-1}^-(2ty), \quad n < 0. \end{aligned}$$

3. Related Operator Groups

Let \mathcal{U} be the group of unitary operators acting on $L^2(\mathbb{R})$. The operators of type (2.6) generate unitary subgroups of \mathcal{U} , which are related to the reproducing kernels of poly-Bergman spaces (Section 5). Consider the subgroups

$$\begin{aligned} \mathcal{D} &= \{D_\delta : \delta > 0\}, \\ \mathcal{E} &= \{E_b : b \in \mathbb{R}\}, \\ \mathcal{T} &= \{T_b : b \in \mathbb{R}\}. \end{aligned}$$

Let \mathbb{R}^+ stand for the set of positive real numbers. We endow \mathbb{R}^+ with the structure of a multiplicative group. For the time being, only the additive structure on \mathbb{R} will be taken into account. Of course the following maps are group homomorphisms

$$\begin{aligned} \Theta : \mathbb{R}^+ \ni \delta &\mapsto D_\delta \in \mathcal{D}, \\ \Phi : \mathbb{R} \ni b &\mapsto E_b \in \mathcal{E}, \\ \Psi : \mathbb{R} \ni b &\mapsto T_b \in \mathcal{T}. \end{aligned}$$

(3.1) The group \mathcal{ED} . Let \mathcal{ED} be the group of unitary operators generated by \mathcal{E} and \mathcal{D} . Since $D_\delta E_b = E_{\delta b} D_\delta$ we have

$$\mathcal{ED} = \{E_b D_\delta : b \in \mathbb{R}, \delta \in \mathbb{R}^+\},$$

and the product on \mathcal{ED} is given by

$$(E_b D_\delta)(E_{\tilde{b}} D_{\tilde{\delta}}) = E_{b+\delta\tilde{b}} D_{\delta\tilde{\delta}}.$$

On the other hand, the scalar multiplication δb is an action of \mathbb{R}^+ on \mathbb{R} , thus the binary operation on the semidirect product $\mathbb{R} \rtimes \mathbb{R}^+$ is given by

$$(b, \delta) \cdot (\tilde{b}, \tilde{\delta}) = (b + \delta\tilde{b}, \delta\tilde{\delta}).$$

Now $E_b D_\delta = E_{\tilde{b}} D_{\tilde{\delta}}$ implies that $b = \tilde{b}$ and $\delta = \tilde{\delta}$, so the following map is a group isomorphism from $\mathbb{R} \rtimes \mathbb{R}^+$ onto \mathcal{ED} :

$$\Phi_{\mathcal{E}} : (b, \delta) \mapsto E_b D_\delta.$$

Changing notation, we identify each complex number $\zeta = t + i\tau$ with (t, τ) . Of course the group $\mathbb{R} \rtimes \mathbb{R}^+$ naturally passes its group structure to Π , where the multiplication is also denoted by \cdot . For $\zeta_k = t_k + i\tau_k \in \Pi$, with $k = 1, 2$, we have

$$X_{\zeta_1} X_{\zeta_2} = X_{\zeta_1 \cdot \zeta_2}.$$

(3.2) The group \mathcal{TD} . Similarly we consider the action of \mathbb{R}^+ on \mathbb{R} given by the product $\frac{1}{\delta}b$. The semidirect product induced by this action is denoted by $\mathbb{R} \rtimes^{-1} \mathbb{R}^+$. It is readily seen that the multiplication on this group is given by

$$(b, \delta) \times (\tilde{b}, \tilde{\delta}) = (b + \frac{1}{\delta}\tilde{b}, \delta\tilde{\delta}).$$

Thus $\mathbb{R} \rtimes^{-1} \mathbb{R}^+$ is isomorphic to the operator group \mathcal{TD} , and the isomorphism is defined as follows

$$\Phi_{\mathcal{T}} : (b, \delta) \mapsto T_b D_{\delta}.$$

PROPOSITION (3.1). *We have the following commutative diagram of group isomorphisms*

$$\begin{array}{ccc} \zeta \in \Pi & \xrightarrow{\Phi_{\mathcal{E}}} & X_{\zeta} \in \mathcal{ED}, \\ \Phi \downarrow & & \downarrow \Phi_F \\ \mathbb{R} \rtimes^{-1} \mathbb{R}^+ & \xrightarrow{\Phi_{\mathcal{T}}} & Y_{\zeta} \in \mathcal{TD} \end{array}$$

where Φ and Φ_F are defined by

$$\begin{aligned} \Phi(b, \delta) &= (-b, \delta^{-1}), \\ \Phi_F(A) &= FAF^*. \end{aligned}$$

Proposition 3.1 implies that

$$Y_{\zeta_1} Y_{\zeta_2} = Y_{\zeta_1 \cdot \zeta_2}.$$

NOTE 1: The group structure on $\mathbb{R} \rtimes \mathbb{R}^+$ generates another one, denoted by $\mathbb{R} \rtimes^* \mathbb{R}^+$, where the binary operation is defined by $(b, \delta) * (\tilde{b}, \tilde{\delta}) = (\tilde{b}, \tilde{\delta}) \cdot (b, \delta)$. Then $\mathbb{R} \rtimes^* \mathbb{R}^+$ is isomorphic to $\mathcal{DT} = \mathcal{TD}$, and the isomorphism is given by $(b, \delta) \mapsto D_{\delta} T_b$.

4. Poly-Bergman kernels

In this section we will establish explicit representations of the reproducing kernels of poly-Bergman spaces ($\lambda = 0$). It was shown in [4] (see also [5]) that the Fourier transform of the weighted poly-Bergman kernel $K_{(n+1)\lambda}(z, \zeta)$ with respect to the real part of $\zeta = t + i\tau$ is given by

$$[(F \otimes I)_{\zeta} \overline{K_{(n+1)\lambda}}](z, \zeta) = \frac{2c_{n\lambda}^2}{\sqrt{2\pi}(\lambda + 1)} t^{\lambda+1} L_n^{\lambda}(2ty) L_n^{\lambda}(2t\tau) e^{-t(\tau+i\bar{z})} \chi_+(t)$$

where $z = x + iy$, L_n^{λ} is the Laguerre polynomial of order λ and degree n , and

$$c_{n\lambda} = (-1)^n \sqrt{n!/\Gamma(n + \lambda + 1)}.$$

We emphasize that all Fourier transforms applied herein are taken with respect to the real variable $t = \text{Re } \zeta$. Thus, the operator $(F \otimes I)_{\zeta}$ acts on $L^2(\mathbb{R}^2)$ with respect to the variable $\zeta = t + i\tau \in \mathbb{C} = \mathbb{R}^2$.

The Fourier transform of $\overline{K_{(n+1)\lambda}(z, \zeta)}$ can be rewritten as

$$(4.1) \quad [(F \otimes I)_{\zeta} \overline{K_{(n+1)\lambda}}](z, \zeta) = \frac{t}{\sqrt{2\pi} 2^{\lambda} (\lambda + 1) (\gamma\tau)^{(\lambda+1)/2}} \ell_{nz}^{\lambda}(t) \ell_{n, i\tau}^{\lambda}(t),$$

where

$$\ell_{nz}^{\lambda}(t) = c_{n\lambda} (2\text{Im } z)^{(\lambda+1)/2} t^{\lambda/2} L_n^{\lambda}(2\text{Im } zt) e^{-i\tau\bar{z}} \chi_+(t).$$

Let ∂_t stand for the partial derivation with respect to t . As usual \hat{g} and \check{g} denote the Fourier and inverse Fourier transform of g , respectively. We will be using the well-known properties $F^*(g * h) = \sqrt{2\pi} \check{g} \check{h}$ and $(F^* \partial_t g)(t) = -it(F^* g)(t)$.

THEOREM (4.2). ($\lambda = 0$) *The reproducing kernel of $\mathcal{A}_{(n+1)}^2(\Pi)$ has the form*

$$\begin{aligned} K_{(n+1)}(z, \zeta) &= \frac{1}{\pi n!} \frac{d^n}{ds^n} \left[\left(\frac{\partial}{\partial \zeta} + \frac{\partial}{\partial \bar{\zeta}} \right) \left\{ \frac{(\bar{z} + s)^n}{\bar{\zeta} + s} \left(\frac{\zeta + s}{\bar{\zeta} + s} \right)^n \right\} \right] \Big|_{s=-z} \\ &= \frac{1}{\pi n!} \frac{d^n}{ds^n} \left[(\bar{z} + s)^n \frac{(\zeta + s)^{n-1}}{(\bar{\zeta} + s)^{n+1}} \left(n \frac{\bar{\zeta} - \zeta}{\bar{\zeta} + s} - \frac{\zeta + s}{\bar{\zeta} + s} \right) \right] \Big|_{s=-z}. \end{aligned}$$

Proof. For the time being, $z \in \Pi$ and $\tau = \text{Im} \zeta > 0$ are fixed. We define the function f as $f(t) = K_{(n+1)}(z, \zeta)$, where $t = \text{Re} \zeta$. Since $\ell_{nz}^\lambda = \ell_{nz}^+$ for $\lambda = 0$, equality (4.1) takes the form

$$\begin{aligned} \hat{f}(t) &= \frac{t}{\sqrt{2\pi} \sqrt{y\tau}} \ell_{nz}^+(t) \ell_{n,ir}^+(t) \\ &= \frac{t}{\sqrt{2\pi} \sqrt{y\tau}} F^* \phi_{nz} F^* \phi_{n,ir} \\ &= \frac{t}{2\pi \sqrt{y\tau}} [F^*(\phi_{nz} * \phi_{n,ir})](t) \\ &= \frac{i}{2\pi \sqrt{y\tau}} [F^* \partial_t(\phi_{nz} * \phi_{n,ir})](t). \end{aligned}$$

Therefore

$$\bar{f}(t) = \frac{i}{2\pi \sqrt{y\tau}} [F^2 \partial_t(\phi_{nz} * \phi_{n,ir})](t).$$

By definition of $\phi_{n\zeta}$, we have

$$\begin{aligned} \phi_{nz}(t) &= \sqrt{\frac{y}{\pi}} \frac{1}{i(\bar{z} + t)} \left(-\frac{z + t}{\bar{z} + t} \right)^n, \\ \phi_{n,ir}(t) &= \sqrt{\frac{\tau}{\pi}} \frac{1}{\tau + it} \left(\frac{\tau - it}{\tau + it} \right)^n. \end{aligned}$$

Thus, the convolution is given by

$$\begin{aligned} \frac{1}{\sqrt{y\tau}} (\phi_{nz} * \phi_{n,ir})(t) &= \frac{1}{\pi} \int_{-\infty}^{\infty} \frac{1}{i(\bar{z} + s)} \left(-\frac{z + s}{\bar{z} + s} \right)^n \frac{1}{\tau + i(t - s)} \left(\frac{\tau - i(t - s)}{\tau + i(t - s)} \right)^n ds \\ &= \frac{1}{\pi} \int_{-\infty}^{\infty} \frac{1}{i(\bar{z} + s)} \left(-\frac{z + s}{\bar{z} + s} \right)^n \frac{1}{i(\bar{\zeta} - s)} \left(\frac{-i\zeta + is}{i\bar{\zeta} - is} \right)^n ds \\ &= -\frac{1}{\pi} \int_{-\infty}^{\infty} \frac{1}{\bar{z} + s} \left(\frac{z + s}{\bar{z} + s} \right)^n \frac{1}{\bar{\zeta} - s} \left(\frac{\zeta - s}{\bar{\zeta} - s} \right)^n ds. \end{aligned}$$

By considering s as a complex variable, the holomorphic function

$$\Phi(s) = \frac{1}{\bar{z} + s} \left(\frac{z + s}{\bar{z} + s} \right)^n \frac{1}{\bar{\zeta} - s} \left(\frac{\zeta - s}{\bar{\zeta} - s} \right)^n$$

has the complex number $s = -\bar{z}$ as unique pole in the upper half-plane. Of course $s = -\bar{z}$ is a pole of order $n + 1$, thus

$$\frac{1}{\sqrt{y\tau}}(\phi_{nz} * \phi_{n,i\tau})(t) = -\frac{2i}{n!} \frac{d^n}{ds^n} \left[\frac{(z+s)^n}{\bar{\zeta}-s} \left(\frac{\zeta-s}{\bar{\zeta}-s} \right)^n \right] \Big|_{s=-\bar{z}}.$$

Since $(F^2g)(t) = g(-t)$, we have $F^2\partial_t = -\partial_t F^2$. Therefore

$$\begin{aligned} \bar{f}(t) &= \frac{1}{\pi n!} F^2 \partial_t \frac{d^n}{ds^n} \left[\frac{(z+s)^n}{\bar{\zeta}-s} \left(\frac{\zeta-s}{\bar{\zeta}-s} \right)^n \right] \Big|_{s=-\bar{z}} \\ &= -\frac{1}{\pi n!} \partial_t \frac{d^n}{ds^n} \left[\frac{(z+s)^n}{-\bar{\zeta}-s} \left(\frac{-\bar{\zeta}-s}{-\bar{\zeta}-s} \right)^n \right] \Big|_{s=-\bar{z}} \\ &= \frac{1}{\pi n!} \frac{d^n}{ds^n} \left[\partial_t \left\{ \frac{(z+s)^n}{\zeta+s} \left(\frac{\bar{\zeta}+s}{\zeta+s} \right)^n \right\} \right] \Big|_{s=-\bar{z}}. \end{aligned}$$

The first equality to be proven follows by conjugating $\overline{f(t)}$. On the other hand, $\partial_t = \frac{\partial}{\partial \zeta} + \frac{\partial}{\partial \bar{\zeta}}$, thus

$$\begin{aligned} \bar{f}(t) &= \frac{1}{\pi n!} \frac{d^n}{ds^n} \left[(z+s)^n \left(-(n+1) \frac{(\bar{\zeta}+s)^n}{(\zeta+s)^{n+2}} + n \frac{(\bar{\zeta}+s)^{n-1}}{(\zeta+s)^{n+1}} \right) \right] \Big|_{s=-\bar{z}} \\ &= \frac{1}{\pi n!} \frac{d^n}{ds^n} \left[(z+s)^n \frac{(\bar{\zeta}+s)^{n-1}}{(\zeta+s)^{n+1}} \left(n \frac{\zeta-\bar{\zeta}}{\zeta+s} - \frac{\bar{\zeta}+s}{\zeta+s} \right) \right] \Big|_{s=-\bar{z}}. \end{aligned}$$

We complete the proof by performing complex conjugation. □

Let us compute now the reproducing kernel of $\mathcal{A}_{n+1}^2(\Pi)$. First of all, by the Christoffel-Darboux identity ([2, 4, 5]) we have

$$\sum_{k=0}^n c_{k\lambda}^2 L_k^\lambda(x) L_k^\lambda(y) = -\frac{(n+1)c_{n\lambda}^2}{x-y} (L_{n+1}^\lambda(x)L_n^\lambda(y) - L_n^\lambda(x)L_{n+1}^\lambda(y)).$$

Thus

$$(4.3) \quad \sum_{k=0}^n \ell_{kz}^\lambda(t) \ell_{k,i\tau}^\lambda(t) = \frac{\sqrt{(n+1)(\lambda+n+1)}}{2t(y-\tau)} (\ell_{n+1,z}^\lambda(t) \ell_{n,i\tau}^\lambda(t) - \ell_{nz}^\lambda(t) \ell_{n+1,i\tau}^\lambda(t)).$$

THEOREM (4.4). ($\lambda = 0$) *The reproducing kernel of $\mathcal{A}_{n+1}^2(\Pi)$ admits the representation*

$$\begin{aligned} K_{n+1}(z, \zeta) &= \frac{-1}{\pi n!(z-\bar{z}-\zeta+\bar{\zeta})} \frac{d^{n+1}}{ds^{n+1}} \left[\frac{(\bar{z}+s)^{n+1}}{\bar{\zeta}+s} \left(\frac{\zeta+s}{\bar{\zeta}+s} \right)^n \right] \Big|_{s=-z} \\ &\quad + \frac{(n+1)}{\pi n!(z-\bar{z}-\zeta+\bar{\zeta})} \frac{d^n}{ds^n} \left[\frac{(\bar{z}+s)^n}{\bar{\zeta}+s} \left(\frac{\zeta+s}{\bar{\zeta}+s} \right)^{n+1} \right] \Big|_{s=-z}. \end{aligned}$$

Proof. Consider $\lambda = 0$. Let $g(t)$ stand for $[(F \otimes I)_\zeta \overline{K_{n+1}}](z, \zeta)$, where $\zeta = t + i\tau$.

Recall that $K_{n+1} = \sum_{k=1}^{n+1} K_{(k)}$. By the Christoffel-Darboux identity we have

$$\begin{aligned} g(t) &= \frac{t}{\sqrt{2\pi y\tau}} \sum_{k=0}^n \ell_{kz}(t) \ell_{k,i\tau}(t) \\ &= \frac{n+1}{2\sqrt{2\pi y\tau}(y-\tau)} \left(\ell_{n+1,z}^+(t) \ell_{n,i\tau}^+(t) - \ell_{nz}^+(t) \ell_{n+1,i\tau}^+(t) \right) \\ &= \frac{n+1}{2\sqrt{2\pi y\tau}(y-\tau)} \left(F^* \phi_{n+1,z} F^* \phi_{n,i\tau} - F^* \phi_{nz} F^* \phi_{n+1,i\tau} \right) \\ &= \frac{n+1}{4\pi\sqrt{y\tau}(y-\tau)} [F^* (\phi_{n+1,z} * \phi_{n,i\tau} - \phi_{nz} * \phi_{n+1,i\tau})](t). \end{aligned}$$

Thus

$$\overline{K_{n+1}}(z, \zeta) = \frac{n+1}{4\pi\sqrt{y\tau}(y-\tau)} (\phi_{n+1,z} * \phi_{n,i\tau} - \phi_{nz} * \phi_{n+1,i\tau})(-t).$$

But

$$\begin{aligned} \frac{1}{2\sqrt{y\tau}} (\phi_{n+1,z} * \phi_{n,i\tau})(t) &= \frac{1}{2\pi} \int_{-\infty}^{\infty} \frac{1}{\bar{z}+s} \left(\frac{z+s}{\bar{z}+s} \right)^{n+1} \frac{1}{\bar{\zeta}-s} \left(\frac{\zeta-s}{\bar{\zeta}-s} \right)^n ds, \\ \frac{1}{2\sqrt{y\tau}} (\phi_{nz} * \phi_{n+1,i\tau})(t) &= \frac{1}{2\pi} \int_{-\infty}^{\infty} \frac{1}{\bar{z}+s} \left(\frac{z+s}{\bar{z}+s} \right)^n \frac{1}{\bar{\zeta}-s} \left(\frac{\zeta-s}{\bar{\zeta}-s} \right)^{n+1} ds. \end{aligned}$$

Therefore

$$\frac{1}{2\sqrt{y\tau}} (\phi_{n+1,z} * \phi_{n,i\tau} - \phi_{nz} * \phi_{n+1,i\tau})(t)$$

equals

$$\frac{i}{(n+1)!} \frac{d^{n+1}}{ds^{n+1}} \left[\frac{(z+s)^{n+1}}{\bar{\zeta}-s} \left(\frac{\zeta-s}{\bar{\zeta}-s} \right)^n \right] \Big|_{s=-\bar{z}} - \frac{i}{n!} \frac{d^n}{ds^n} \left[\frac{(z+s)^n}{\bar{\zeta}-s} \left(\frac{\zeta-s}{\bar{\zeta}-s} \right)^{n+1} \right] \Big|_{s=-\bar{z}}.$$

By evaluating at $-t$ and then performing complex conjugation, the preceding expression takes the form

$$\frac{i}{(n+1)!} \frac{d^{n+1}}{ds^{n+1}} \left[\frac{(\bar{z}+s)^{n+1}}{\bar{\zeta}+s} \left(\frac{\zeta+s}{\bar{\zeta}+s} \right)^n \right] \Big|_{s=-z} - \frac{i}{n!} \frac{d^n}{ds^n} \left[\frac{(\bar{z}+s)^n}{\bar{\zeta}+s} \left(\frac{\zeta+s}{\bar{\zeta}+s} \right)^{n+1} \right] \Big|_{s=-z}.$$

Finally, this expression multiplied by $(n+1)/[2\pi(y-\tau)]$ equals the reproducing poly-Bergman kernel, where $2i(y-\tau) = z - \bar{z} - \zeta + \bar{\zeta}$. \square

THEOREM (4.5). ($\lambda = 0$) *The reproducing poly-Bergman kernel of $\mathcal{A}_{(n+1)}^2(\Pi)$ has the form*

$$\begin{aligned} \tilde{K}_{(n+1)}(z, \zeta) &= \frac{1}{\pi n!} \frac{d^n}{ds^n} \left[\left(\frac{\partial}{\partial \zeta} + \frac{\partial}{\partial \bar{\zeta}} \right) \left\{ \frac{(z+s)^n}{\zeta+s} \left(\frac{\bar{\zeta}+s}{\bar{\zeta}+s} \right)^n \right\} \right] \Big|_{s=-\bar{z}} \\ &= \frac{1}{\pi n!} \frac{d^n}{ds^n} \left[(z+s)^n \frac{(\bar{\zeta}+s)^{n-1}}{(\bar{\zeta}+s)^{n+1}} \left(n \frac{\zeta-\bar{\zeta}}{\zeta+s} - \frac{\bar{\zeta}+s}{\zeta+s} \right) \right] \Big|_{s=-\bar{z}}. \end{aligned}$$

THEOREM (4.6). ($\lambda = 0$) *The reproducing poly-Bergman kernel of $\tilde{\mathcal{A}}_{n+1}^2(\Pi)$ admits the representation*

$$\begin{aligned} \tilde{K}_{n+1}(z, \zeta) &= \frac{1}{\pi n!(z - \bar{z} - \zeta + \bar{\zeta})} \frac{d^{n+1}}{ds^{n+1}} \left[\frac{(z+s)^{n+1}}{\zeta+s} \left(\frac{\bar{\zeta}+s}{\zeta+s} \right)^n \right] \Bigg|_{s=-\bar{z}} \\ &\quad - \frac{(n+1)}{\pi n!(z - \bar{z} - \zeta + \bar{\zeta})} \frac{d^n}{ds^n} \left[\frac{(z+s)^n}{\zeta+s} \left(\frac{\bar{\zeta}+s}{\zeta+s} \right)^{n+1} \right] \Bigg|_{s=-\bar{z}}. \end{aligned}$$

We conclude this section mentioning some general properties of poly-Bergman kernels. Let \mathcal{A} be any of the poly-Bergman spaces $\mathcal{A}_n^2(\Pi)$, $\mathcal{A}_{(n)}^2(\Pi)$, $\tilde{\mathcal{A}}_n^2(\Pi)$ or $\tilde{\mathcal{A}}_{(n)}^2(\Pi)$. Let $K(z, \zeta)$ denote the reproducing poly-Bergman kernel of \mathcal{A} . Then, for any n -analytic (anti-analytic) function $f \in \mathcal{A}$,

$$f(z) = \int_{\Pi} f(\zeta) K(z, \zeta) dV(\zeta).$$

Furthermore

- $K(z, \zeta) = \overline{K(\zeta, z)}$,
- $|f(z)| \leq \|f\| \|K(z, \cdot)\| \quad \forall z \in \Pi, \quad \forall f \in \mathcal{A}$,
- $\sup_{\|f\|=1} \|f(z)\| = \|K(z, \cdot)\|$,
- $\|K(z, \cdot)\| = \sqrt{K(z, z)}$.

COROLLARY (4.7). *The norms of the reproducing kernels are given by*

- 1) $K_{(n)}(z, z) = \tilde{K}_{(n)}(z, z) = -\frac{2n-1}{\pi(\bar{z}-z)^2} = \frac{2n-1}{4\pi y^2}$,
- 2) $K_n(z, z) = \tilde{K}_n(z, z) = -\frac{n^2}{\pi(\bar{z}-z)^2} = \frac{n^2}{4\pi y^2}$.

Proof. We will compute $K_{(n+1)}(z, z)$. By Theorem 4.2 and the Leibnitz formula for derivation, we have

$$\begin{aligned} \pi n! K_{(n+1)}(z, z) &= \frac{d^n}{ds^n} \left[\frac{(z+s)^{n-1}}{(\bar{z}+s)^2} (n[\bar{z}-z] - [z+s]) \right] \Bigg|_{s=-z} \\ &= n^2(\bar{z}-z) \frac{d^{n-1}}{ds^{n-1}} (z+s)^{n-1} \frac{d}{ds} \frac{1}{(\bar{z}+s)^2} \Bigg|_{s=-z} \\ &\quad - \frac{d^n}{ds^n} (z+s)^n \frac{1}{(\bar{z}+s)^2} \Bigg|_{s=-z} \\ &= -\frac{n!(2n+1)}{(\bar{z}-z)^2}. \end{aligned}$$

This proves statement 1). Statement 2) follows from $K_n(z, z) = \sum_{k=1}^n K_{(k)}(z, z)$. □

5. Weighted Poly-Bergman kernels

In this section we will see that the weighted poly-Bergman kernels are given by the action of the unitary groups $\mathcal{E}\mathcal{D}$ and $\mathcal{T}\mathcal{D}$ on the orthonormal systems of

functions

$$\begin{aligned} \ell_n^\lambda(t) &= c_{n\lambda} t^{\lambda/2} L_n^\lambda(t) e^{-t/2} \chi_+(t), \\ \phi_n^\lambda &= F \ell_n^\lambda. \end{aligned}$$

For each $\text{Im } \zeta > 0$, the unitary operator X_ζ and the Fourier transform give rise to new systems of orthonormal functions in $L^2(\mathbb{R})$:

$$\begin{aligned} \ell_{n\zeta}^\lambda &= X_\zeta D_2 \ell_n^\lambda, \\ \phi_{n\zeta}^\lambda &= F \ell_{n\zeta}^\lambda. \end{aligned}$$

In order to simplify our notation we define

$$\begin{aligned} k_n^\lambda &= D_2 \ell_n^\lambda, \\ \psi_n^\lambda &= F k_n^\lambda. \end{aligned}$$

THEOREM (5.1). *The reproducing kernel of $\mathcal{A}_{(n+1)\lambda}^2(\Pi)$ is given by*

$$\begin{aligned} K_{(n+1)\lambda}(z, \zeta) &= a_{(\lambda)}(y, \tau) \partial_t \overline{\langle X_z k_n^\lambda, X_\zeta k_n^\lambda \rangle} \\ &= a_{(\lambda)}(y, \tau) \partial_t \overline{\langle Y_z \psi_n^\lambda, Y_\zeta \psi_n^\lambda \rangle}, \end{aligned}$$

where $z = x + yi$, $\zeta = t + \tau i$, and

$$a_{(\lambda)}(y, \tau) = \frac{i}{2^{\lambda+1} \pi (\lambda + 1) (\gamma\tau)^{(\lambda+1)/2}}.$$

Proof. We define $f(t) = K_{(n+1)\lambda}(z, \zeta)$. Repeating some arguments given in the proof of Theorem 4.2 we have

$$\begin{aligned} \hat{f}(t) &= \frac{t}{\sqrt{2\pi} 2^\lambda (\lambda + 1) (\gamma\tau)^{(\lambda+1)/2}} \ell_{nz}^\lambda(t) \ell_{n,ir}^\lambda(t) \\ &= \frac{i}{2\pi 2^\lambda (\lambda + 1) (\gamma\tau)^{(\lambda+1)/2}} [F^* \partial_t (\phi_{nz}^\lambda * \phi_{n,ir}^\lambda)](t). \end{aligned}$$

Since $F^2 \partial_t = -\partial_t F^2$ we have

$$\bar{f}(t) = -a_{(\lambda)}(y, \tau) [\partial_t F^2 (\phi_{nz}^\lambda * \phi_{n,ir}^\lambda)](t).$$

The convolution of two functions in $L^2(\mathbb{R})$ can be written as $(g * h)(t) = \langle g, F^2 T_{-t} \bar{h} \rangle$. Note now that $FT_{-t} F^* X_{ir} = X_{-\bar{\zeta}}$ for t, τ fixed. Therefore the convolution of ϕ_{nz}^λ and $\phi_{n,ir}^\lambda$ evaluated at t is given by

$$\begin{aligned} (\phi_{nz}^\lambda * \phi_{n,ir}^\lambda)(t) &= \langle FX_z D_2 \ell_n^\lambda, F^2 T_{-t} \overline{FX_{ir} D_2 \ell_n^\lambda} \rangle \\ &= \langle X_z D_2 \ell_n^\lambda, FT_{-t} F^* X_{ir} D_2 \ell_n^\lambda \rangle \\ &= \langle X_z D_2 \ell_n^\lambda, X_{-\bar{\zeta}} D_2 \ell_n^\lambda \rangle. \end{aligned}$$

By taking the Fourier transform twice with respect to t we get

$$(5.2) \quad [F^2 (\phi_{nz}^\lambda * \phi_{n,ir}^\lambda)](t) = \langle X_z k_n^\lambda, X_\zeta k_n^\lambda \rangle.$$

The first part of the theorem follows immediately. The second equality follows from $FX_z = Y_z F$ and $FX_\zeta = Y_\zeta F$. □

THEOREM (5.3). *The conjugation of the reproducing kernel of $\mathcal{A}_{n+1,\lambda}^2(\Pi)$ is given by*

$$\begin{aligned} \overline{K_{n+1,\lambda}(z, \zeta)} &= a_\lambda (\langle X_z k_{n+1}^\lambda, X_\zeta k_n^\lambda \rangle - \langle X_z k_n^\lambda, X_\zeta k_{n+1}^\lambda \rangle) \\ &= a_\lambda (\langle Y_z \psi_{n+1}^\lambda, Y_\zeta \psi_n^\lambda \rangle - \langle Y_z \psi_n^\lambda, Y_\zeta \psi_{n+1}^\lambda \rangle) \end{aligned}$$

where $z = x + yi$, $\zeta = t + \tau i$, and

$$a_\lambda = a_\lambda(y, \tau) = \frac{\sqrt{(n+1)(\lambda+n+1)}}{2\pi 2^{\lambda+1}(\lambda+1)(y-\tau)(y\tau)^{(\lambda+1)/2}}.$$

Proof. Let $g(t)$ be $\overline{K_{n+1,\lambda}(z, \zeta)}$. Since $K_{n+1,\lambda} = \sum_{k=1}^{n+1} K_{(k)\lambda}$, by (4.1) and (4.3) we have

$$\begin{aligned} \widehat{g}(t) &= \frac{t}{\sqrt{2\pi} 2^\lambda (\lambda+1) (y\tau)^{(\lambda+1)/2}} \sum_{k=0}^n \ell_{kz}^\lambda(t) \ell_{k,ir}^\lambda(t) \\ &= \sqrt{2\pi} a_\lambda (\ell_{n+1,z}^\lambda(t) \ell_{n,ir}^\lambda(t) - \ell_{nz}^\lambda(t) \ell_{n+1,ir}^\lambda(t)) \\ &= \sqrt{2\pi} a_\lambda (F^* \phi_{n+1,z}^\lambda F^* \phi_{n,ir}^\lambda - F^* \phi_{nz}^\lambda F^* \phi_{n+1,ir}^\lambda)(t) \\ &= a_\lambda [F^* (\phi_{n+1,z}^\lambda * \phi_{n,ir}^\lambda - \phi_{nz}^\lambda * \phi_{n+1,ir}^\lambda)](t) \end{aligned}$$

or

$$\overline{g}(t) = a_\lambda [F^2 (\phi_{n+1,z}^\lambda * \phi_{n,ir}^\lambda - \phi_{nz}^\lambda * \phi_{n+1,ir}^\lambda)](t).$$

The rest of the proof follows from an equality similar to (5.2). □

Acknowledgement

This work was performed as part of PROMEP project #103.5/04/1411 “Knowledge Generation and Application” (“Fomento a la Generación y Aplicación del Conocimiento”).

J. RAMÍREZ ORTEGA
 FACULTAD DE MATEMÁTICAS
 UNIVERSIDAD VERACRUZANA
 XALAPA VER., MÉXICO, C.P. 91000
 josramirez@uv.mx

REFERENCES

- [1] S. BERGMAN, *The Kernel Function and Conformal Mapping*, Amer. Math. Soc., Providence, 1970.
- [2] T. S. CHIHARA, *An Introduction to Orthogonal Polynomials*, Gordon and Breach Science Publishers, New York, 1978.
- [3] A. DZHURAEV, *Methods of Singular Integral Equations*, Longman Scientific & Technical, New York, 1992.
- [4] J. RAMÍREZ, *Reproducing kernels of weighted poly-Bergman spaces on the upper half-plane*, Bol. Soc. Mat. Mexicana, **13** No 2 (2007) 345–356.
- [5] N. N. LEBEDEV, *Special Functions and Their Applications*, Dover, New York, 1972.
- [6] N. L. VASILEVSKI, *On the structure of Bergman and Poly-Bergman Spaces*, Integral Equations Operator Theory **33** (1999), 471–488.
- [7] N. L. VASILEVSKI, *The Extended Field of Operator Theory*, ed. M. A. Dritschel, Operator Theory: Advances and Applications Vol 171 (2006), 349-359.

AN OPTIMAL CONTROL PROBLEM ON THE LIE GROUP $SE(2, \mathbb{R}) \times SO(2)$

ANANIA ARON, CAMELIA POP, AND MIRCEA PUTA

ABSTRACT. An optimal control problem on the Lie group $SE(2, \mathbb{R}) \times SO(2)$ is discussed and some of its dynamical and geometrical properties are pointed out.

1. Introduction

In the last time there was a great deal of interest in the study of control problems on matrix Lie group due to their applications in spacecraft dynamics and subacvatic dynamics. The goal of our paper is to study an optimal control problem on the Lie group $SE(2, \mathbb{R}) \times SO(2)$ and to point out some of its dynamical and geometrical properties.

2. The geometrical picture of the problem

Let G be the Lie group given by:

$$G = SE(2, \mathbb{R}) \times SO(2)$$

$$= \left\{ \begin{bmatrix} \cos \varphi & -\sin \varphi & x & 0 & 0 \\ \sin \varphi & \cos \varphi & y & 0 & 0 \\ 0 & 0 & 1 & 0 & 0 \\ 0 & 0 & 0 & \cos \theta & -\sin \theta \\ 0 & 0 & 0 & \sin \theta & \cos \theta \end{bmatrix} \middle| \begin{array}{l} x, y \in \mathbb{R}, \\ \varphi, \theta \in [0, 2\pi] \end{array} \right\}$$

Then a basis of its Lie algebra $se(2, \mathbb{R}) \times so(2)$ is given by:

$$A_1 = \begin{bmatrix} 0 & -1 & 0 & 0 & 0 \\ 1 & 0 & 0 & 0 & 0 \\ 0 & 0 & 0 & 0 & 0 \\ 0 & 0 & 0 & 0 & 0 \\ 0 & 0 & 0 & 0 & 0 \end{bmatrix}, \quad A_2 = \begin{bmatrix} 0 & 0 & 0 & 0 & 0 \\ 0 & 0 & 0 & 0 & 0 \\ 0 & 0 & 0 & 0 & 0 \\ 0 & 0 & 0 & 0 & -1 \\ 0 & 0 & 0 & 1 & 0 \end{bmatrix},$$

$$A_3 = \begin{bmatrix} 0 & 0 & 1 & 0 & 0 \\ 0 & 0 & 0 & 0 & 0 \\ 0 & 0 & 0 & 0 & 0 \\ 0 & 0 & 0 & 0 & 0 \\ 0 & 0 & 0 & 0 & 0 \end{bmatrix}, \quad A_4 = \begin{bmatrix} 0 & 0 & 0 & 0 & 0 \\ 0 & 0 & 1 & 0 & 0 \\ 0 & 0 & 0 & 0 & 0 \\ 0 & 0 & 0 & 0 & 0 \\ 0 & 0 & 0 & 0 & 0 \end{bmatrix}.$$

The Lie algebra structure of \mathcal{G} is given by the following table:

2000 *Mathematics Subject Classification*: 34H05.

Keywords and phrases: optimal control, nonlinear stability, Lie-Trotter algorithm, Kahan algorithm.

$[\cdot, \cdot]$	A_1	A_2	A_3	A_4
A_1	0	0	A_4	$-A_3$
A_2	0	0	0	0
A_3	$-A_4$	0	0	0
A_4	A_3	0	0	0

It is not hard to see now that the minus-Lie-Poisson structure on \mathcal{G}^* is generated by the matrix:

$$\Pi_- = \begin{bmatrix} 0 & 0 & -x_4 & x_3 \\ 0 & 0 & 0 & 0 \\ x_4 & 0 & 0 & 0 \\ -x_3 & 0 & 0 & 0 \end{bmatrix}.$$

An easy computation leads us via Chow's theorem [6] to:

PROPOSITION (2.1). *There exists three left invariant controllable systems on G , namely:*

$$(2.2) \quad \dot{X} = X(A_1u_1 + A_2u_2 + A_3u_3),$$

$$(2.3) \quad \dot{X} = X(A_1u_1 + A_2u_2 + A_4u_4),$$

$$(2.4) \quad \dot{X} = X(A_1u_1 + A_2u_2 + A_3u_3 + A_4u_4),$$

where $X \in G$.

The goal of our paper is to study some geometrical and dynamical properties for the system (2.2). Similar results can also be obtained for the systems (2.3) and (2.4).

3. An optimal control problem for the system (2.2)

Let J be the cost function given by:

$$J(u_1, u_2, u_3) = \frac{1}{2} \int_0^{t_f} [c_1u_1^2(t) + c_2u_2^2(t) + c_3u_3^2(t)] dt$$

$c_1 > 0, c_2 > 0, c_3 > 0$.

Then we have:

PROPOSITION (3.1). *The controls that minimize J and steer the system (2.2) from $X = X_0$ at $t = 0$ to $X = X_f$ at $t = t_f$ are given by:*

$$u_1 = \frac{1}{c_1}x_1, \quad u_2 = \frac{1}{c_2}x_2, \quad u_3 = \frac{1}{c_3}x_3,$$

where x_i 's are solutions of:

$$(3.2) \quad \begin{cases} \dot{x}_1 = -\frac{1}{c_3}x_3x_4 \\ \dot{x}_2 = 0 \\ \dot{x}_3 = \frac{1}{c_1}x_1x_4 \\ \dot{x}_4 = -\frac{1}{c_1}x_1x_3. \end{cases}$$

Proof. Let us apply Krishnaprasad’s theorem [10]. It follows that the optimal Hamiltonian is given by:

$$H(x_1, x_2, x_3, x_4) = \frac{1}{2} \left(\frac{x_1^2}{c_1} + \frac{x_2^2}{c_2} + \frac{x_3^2}{c_3} \right).$$

It is in fact the controlled Hamiltonian \bar{H} given by:

$$\bar{H}(x_1, x_2, x_3, x_4) = x_1 u_1 + x_2 u_2 + x_3 u_3 - \frac{1}{2}(c_1 u_1^2 + c_2 u_2^2 + c_3 u_3^2),$$

which is reduced to \mathcal{G}^* via Poisson reduction. Then the optimal controls are given by:

$$u_1 = \frac{1}{c_1} x_1, \quad u_2 = \frac{1}{c_2} x_2, \quad u_3 = \frac{1}{c_3} x_3,$$

where x_i ’s are solutions of the reduced Hamilton’s equations given by:

$$[\dot{x}_1, \dot{x}_2, \dot{x}_3, \dot{x}_4]^t = \Pi_- \cdot \nabla H$$

which are nothing else then the required equations (3.2). □

Remark (3.3). It is easy to see from the equations (3.2) that x_2 =constant and so the dynamics (3.2) can be put in the equivalent form:

$$(3.4) \quad \begin{cases} \dot{x}_1 = -\frac{1}{c_3} x_3 x_4 \\ \dot{x}_3 = \frac{1}{c_1} x_1 x_4 \\ \dot{x}_4 = -\frac{1}{c_1} x_1 x_3. \end{cases}$$

PROPOSITION (3.5). *The dynamics (3.4) has the following Hamilton-Poisson realization:*

$$(\mathbb{R}^3, \Pi, H),$$

where

$$\Pi = \begin{bmatrix} 0 & -x_4 & x_3 \\ x_4 & 0 & 0 \\ -x_3 & 0 & 0 \end{bmatrix}$$

and

$$H(x_1, x_3, x_4) = \frac{1}{2} \left(\frac{x_1^2}{c_1} + \frac{x_3^2}{c_3} \right).$$

Proof. Indeed, it is not hard to see that the dynamics (3.4) can be put in the equivalent form:

$$[\dot{x}_1, \dot{x}_3, \dot{x}_4]^t = \Pi \cdot \nabla H,$$

as required. □

Via Bermejo-Feiren’s technique [3] we are lead immediately to:

PROPOSITION (3.6). *The Poisson structure Π has only one functionally independent Casimir given by:*

$$C(x_1, x_3, x_4) = \frac{1}{2}(x_3^2 + x_4^2).$$

Remark (3.7). The phase curves of the dynamics (3.4) are intersections of

$$\frac{x_1^2}{c_1} + \frac{x_3^2}{c_3} = \text{constant}$$

with

$$x_3^2 + x_4^2 = \text{constant},$$

see the Figure 3.1.

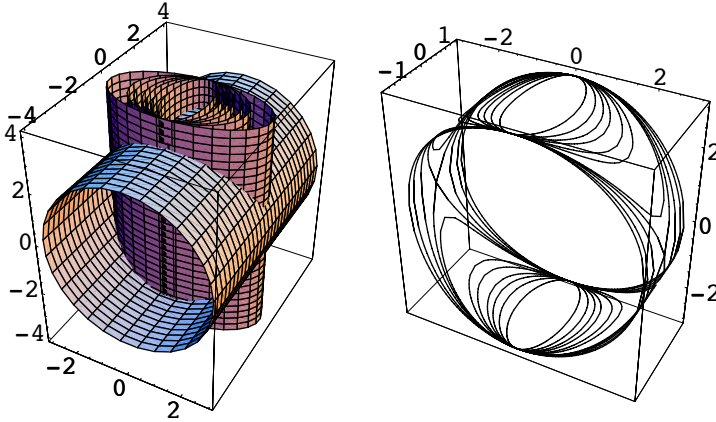

Figure 3.1. The phase curves of the system (3.4)

PROPOSITION (3.8). *The dynamics (3.4) has an infinite number of Hamilton-Poisson realizations.*

Proof. An easy computation shows us that the triples:

$$(\mathbb{R}^3, \{\cdot, \cdot\}_{ab}, H_{cd}),$$

where

$$\{f, g\}_{ab} = -\nabla C_{ab} \cdot (\nabla f \times \nabla g), \quad (\forall) f, g \in C^\infty(\mathbb{R}^3, \mathbb{R})$$

$$C_{ab} = aC + bH,$$

$$H_{cd} = cC + dH,$$

$$H(x_1, x_3, x_4) = \frac{1}{2} \left(\frac{x_1^2}{c_1} + \frac{x_3^2}{c_3} \right),$$

$$C(x_1, x_3, x_4) = \frac{1}{2}(x_3^2 + x_4^2),$$

$$a, b, c, d \in \mathbb{R}, \quad ad - bc = 1,$$

define Hamilton-Poisson realizations of the dynamics (3.4), as required. \square

Remark (3.9). The above proposition tell us in fact that the equation (3.4) is unchanged, so the trajectories of motion in \mathbb{R}^3 remain the same when H and C are replaced by $SL(2, \mathbb{R})$ combinations of H and C .

PROPOSITION (3.10). *The dynamics (3.4) can be reduced to the pendulum dynamics.*

Proof. It is clear that

$$\frac{x_1^2}{c_1} + \frac{x_3^2}{c_3} = 2H$$

and

$$x_3^2 + x_4^2 = 2C$$

are constants of motion. If we take now

$$\begin{cases} x_3 = \sqrt{2C} \cos \theta \\ x_4 = \sqrt{2C} \sin \theta, \end{cases}$$

then we have successively:

$$\dot{x}_3 = -\sqrt{2C} \sin \theta \cdot \dot{\theta} = -\sqrt{2C} \frac{x_4}{\sqrt{2C}} \cdot \dot{\theta}$$

and so

$$\dot{\theta} = -\frac{\dot{x}_3}{x_4} = -\frac{1}{c_1} \frac{x_1 x_4}{x_4} = -\frac{1}{c_1} x_1.$$

Differentiating again we obtain:

$$\begin{aligned} \ddot{\theta} &= -\frac{1}{c_1} \left(-\frac{1}{c_3} \right) x_3 x_4 \\ &= \frac{1}{c_1 c_3} 2C \sin \theta \cos \theta \end{aligned}$$

or equivalent:

$$\ddot{\theta} = \frac{C}{c_1 c_3} \sin 2\theta,$$

which is the pendulum dynamics, as required. \square

4. Stability

It is not hard to see that the equilibrium states of our dynamics (3.4) are:

$$e_1^M = (M, 0, 0), \quad M \in \mathbb{R}$$

$$e_2^M = (0, M, 0), \quad M \in \mathbb{R}$$

$$e_3^M = (0, 0, M), \quad M \in \mathbb{R}.$$

Let A be the matrix of the linear part of our system (3.4), i.e.,

$$A = \begin{bmatrix} 0 & -\frac{1}{c_3} x_4 & -\frac{1}{c_3} x_3 \\ \frac{1}{c_1} x_4 & 0 & \frac{1}{c_1} x_1 \\ -\frac{1}{c_1} x_3 & -\frac{1}{c_1} x_1 & 0 \end{bmatrix}$$

Then the characteristic roots of $A(e_1^M)$ [resp. $A(e_2^M)$, resp. $A(e_3^M)$] are respectively given by:

$$\lambda_1 = 0, \quad \lambda_{2,3} = \pm i \frac{M}{c_1}$$

[resp]

$$\lambda_1 = 0, \quad \lambda_{2,3} = \pm \frac{M}{\sqrt{c_1 c_3}}$$

[resp]

$$\lambda_1 = 0, \quad \lambda_{2,3} = \pm i \frac{M}{\sqrt{c_1 c_3}}$$

and so we can conclude that:

PROPOSITION (4.1). *The equilibrium states $e_1^M, e_2^M, e_3^M, M \in \mathbb{R}$, have the following behavior:*

- (i) $e_1^M, M \in \mathbb{R}$ is spectrally stable.
- (ii) $e_2^M, M \in \mathbb{R}$ is unstable.
- (iii) $e_3^M, M \in \mathbb{R}$ is spectrally stable.

We can now pass to discuss the nonlinear stability of the equilibrium states e_1^M and $e_3^M, M \in \mathbb{R}$.

PROPOSITION (4.2). *The equilibrium states $e_1^M, M \in \mathbb{R}^*$, are nonlinear stable.*

Proof. We shall make the proof using Arnold's technique [2] see also [4]. Let $F_\lambda \in C^\infty(\mathbb{R}^3, \mathbb{R})$ be the smooth function given by:

$$F_\lambda(x_1, x_3, x_4) \stackrel{\text{def}}{=} \frac{1}{2}(x_3^2 + x_4^2) + \frac{\lambda}{2} \left(\frac{x_1^2}{c_1} + \frac{x_3^2}{c_3} \right).$$

Then we have successively:

- (i) $\nabla F_\lambda(e_1^M) = 0$, iff $\lambda = 0$.

- (ii) $W = \ker dH(e_1^M) = \text{span} \left(\begin{bmatrix} 0 \\ 1 \\ 0 \end{bmatrix}, \begin{bmatrix} 0 \\ 0 \\ 1 \end{bmatrix} \right)$.

- (iii) $(\forall)v \in W$, i.e, $v = [0, \alpha, \beta]^t, \alpha, \beta \in \mathbb{R}$ we have:

$$v^t \nabla^2 F_0(e_1^M) v = \alpha^2 + \beta^2$$

and so

$$\nabla^2 F_0(e_1^M) \Big|_{W \times W}$$

is positive definite.

Therefore, via Arnold's technique, the equilibrium states $e_1^M, M \in \mathbb{R}^*$ are nonlinear stable as required. \square

PROPOSITION (4.3). *The equilibrium states $e_3^M, M \in \mathbb{R}^*$, are nonlinear stable.*

Proof. We shall make the proof using Arnold's method [2] see also [4]. Let $G_\lambda \in C^\infty(\mathbb{R}^3, \mathbb{R})$ be the smooth function given by:

$$G_\lambda(x_1, x_3, x_4) = \frac{1}{2} \left(\frac{x_1^2}{c_1} + \frac{x_3^2}{c_3} \right) + \frac{\lambda}{2} (x_3^2 + x_4^2).$$

Then we have successively:

- (i) $\nabla G_\lambda(e_3^M) = 0$ iff $\lambda = 0$.

- (ii) $W = \ker dC(e_3^M) = \text{span} \left(\begin{bmatrix} 1 \\ 0 \\ 0 \end{bmatrix}, \begin{bmatrix} 0 \\ 1 \\ 0 \end{bmatrix} \right)$.

(iii) $(\forall)v \in W$, i.e, $v = [\alpha, \beta, 0]^t$, $\alpha, \beta \in \mathbb{R}$ we have:

$$v^t \nabla^2 G_0(e_3^M) v = \frac{1}{c_1} \alpha^2 + \frac{1}{c_3} \beta^2$$

and so

$$\nabla^2 G_0(e_3^M) \Big|_{W \times W}$$

is positive definite.

Therefore, via Arnold’s method, the equilibrium states e_3^M , $M \in \mathbb{R}^*$ are nonlinear stable as required. \square

Remark (4.4). It is not hard to see that the equilibrium state $(0, 0, 0)$ is nonlinear stable. Indeed, this is a consequence of Lyapunov direct method [7] via the Lyapunov function $H + C$.

5. The existence of periodic solutions

For begining, let us observe that the Lie algebra $(\mathbb{R}^3, [\cdot, \cdot])$ is isomorphic to the Lie algebra $(se(2, \mathbb{R}), [\cdot, \cdot])$ and so the Poisson structure Π is in fact a minus-Lie-Poisson structure on $(\mathbb{R}^3)^* \simeq (se(2, \mathbb{R}))^* \simeq \mathbb{R}^3$.

It is clear that the restriction of our system (3.4) to the generic coadjoint orbit:

$$x_3^2 + x_4^2 = M^2$$

gives rise to a classical Hamiltonian system. Then we have:

PROPOSITION (5.1). *Near to $e_3^M = (0, 0, M)$, $M \in \mathbb{R}^*$, the reduced dynamics has, for each sufficiently small value of the reduced energy, at least 1-periodic solution whose period is close to $2\pi\sqrt{c_1 c_3}/|M|$.*

Proof. Indeed, we have successively:

(i) The matrix of the linear part of the reduced dynamics has purely imaginary roots. More exactly:

$$\lambda_{2,3} = \pm Mi / \sqrt{c_1 c_3}.$$

(ii) $\text{span}(\nabla C(e_3^M)) = V_0$, where

$$V_0 = \ker(A(e_3^M)).$$

(iii) The reduced Hamiltonian has a local minimum at the equilibrium state e_3^M (see the proof of Proposition 4.3).

Then our assertion follows via the Moser-Weinstein theorem with zero eigenvalue, see for details [5]. \square

6. Lax formulation and numerical integration of the dynamics (3.4)

A long but straightforward computation or using eventually MATHEMATICA leads us to:

PROPOSITION (6.1). *The dynamics (3.4) has the following formulation:*

$$\dot{L} = [L, B],$$

where

$$L = \begin{bmatrix} x_4 & \frac{c_3(x_3 - x_1)}{c_1 + c_3} \\ x_1 + x_3 & -x_4 \end{bmatrix}$$

and

$$B = \begin{bmatrix} x_4 & x_3 \\ c_1 & 2c_1 \\ \frac{c_1 + c_3}{2c_1c_3}x_3 & 0 \end{bmatrix}.$$

Let us pass now to the numerical integration of the dynamics (3.4).

It is easy to see that for the equations (3.4), Kahan's integrator [9] can be written in the following form:

$$(6.2) \quad \begin{cases} x_1^{n+1} - x_1^n = -\frac{h}{2c_3}(x_3^{n+1}x_4^n + x_4^{n+1}x_3^n) \\ x_3^{n+1} - x_3^n = \frac{h}{2c_1}(x_1^{n+1}x_4^n - x_4^{n+1}x_1^n) \\ x_4^{n+1} - x_4^n = -\frac{h}{2c_1}(x_1^{n+1}x_3^n - x_3^{n+1}x_1^n) \end{cases}$$

A long but straightforward computation or using eventually MATHEMATICA lead us to:

PROPOSITION (6.3). *Kahan's integrator (6.2) has the following properties:*

- (i) *It is not Poisson preserving.*
- (ii) *It does not preserve the Casimir C of our Poisson configuration (\mathbb{R}^3, Π) .*
- (iii) *It does not preserve the Hamiltonian H of our system (3.4).*

We shall discuss now the numerical integration of the dynamics (3.4) via the Lie-Trotter integrator [11], [12], [13].

For beginning, let us observe that the Hamiltonian vector field X_H splits as follows:

$$X_H = X_{H_1} + X_{H_3},$$

where

$$H_1(x_1, x_3, x_4) = \frac{1}{2c_1}x_1^2$$

and

$$H_3(x_1, x_3, x_4) = \frac{1}{2c_3}x_3^2.$$

Their corresponding integral curves are respectively given by:

$$\begin{bmatrix} x_1(t) \\ x_3(t) \\ x_4(t) \end{bmatrix} = A_i \begin{bmatrix} x_1(0) \\ x_3(0) \\ x_4(0) \end{bmatrix}, \quad i = 1, 3,$$

where

$$\begin{cases} A_1 = \begin{bmatrix} 1 & 0 & 0 \\ 0 & \cos at & \sin at \\ 0 & -\sin at & \cos at \end{bmatrix}, \\ a = \frac{1}{c_1}x_1(0) \end{cases}$$

and

$$\begin{cases} A_3 = \begin{bmatrix} 1 & 0 & -bt \\ 0 & 1 & 0 \\ 0 & 0 & 1 \end{bmatrix}, \\ b = \frac{1}{c_3} x_3(0) \end{cases}$$

Then the Lie-Trotter integrator is given by:

$$(6.4) \quad \begin{bmatrix} x_1^{n+1} \\ x_3^{n+1} \\ x_4^{n+1} \end{bmatrix} = A_1 A_3 \begin{bmatrix} x_1^n \\ x_3^n \\ x_4^n \end{bmatrix};$$

Now, a direct computation or using eventually MATHEMATICA leads us to:

PROPOSITION (6.5). *The Lie-Trotter integrator (6.4) has the following properties:*

- (i) *It preserves the Poisson structure Π .*
- (ii) *It preserves the Casimir C of our Poisson configuration (\mathbb{R}^3, Π) .*
- (iii) *It doesn't preserve the Hamiltonian H of our system (3.4).*
- (iv) *Its restriction to the coadjoint orbit $(\mathcal{O}_k, \omega_k)$, where*

$$\mathcal{O}_k = \{(x_1, x_3, x_4) \in \mathbb{R}^3 \mid x_3^2 + x_4^2 = 2k^2\}$$

and ω_k is the Kirilov-Kostant-Souriau symplectic structure on \mathcal{O}_k gives rise to a symplectic integrator.

Remark (6.6). If we make a comparison with the 4th-step Runge-Kutta method we obtain almost the same results. However, Kahan's integrator and the Lie-Trotter integrator have the advantage to be easier implemented, see Figures 6.1, 6.2 and 6.3.

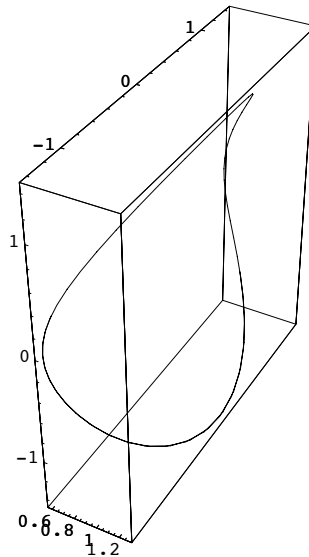

Figure 6.1. The 4th-step Runge-Kutta

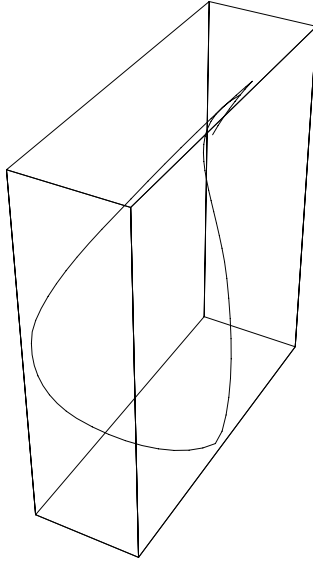

Figure 6.2. The Kahan integrator

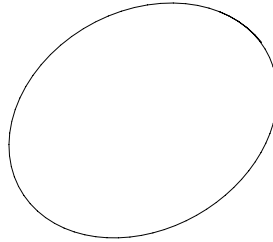

Figure 6.3. The Lie-Trotter integrator

7. Heteroclinic orbits for the dynamics (3.4)

For beginning, let us observe that our dynamics (3.4) can be put in the equivalent form:

$$(7.1) \quad \begin{cases} \dot{x}_1 = a_1 x_3 x_4 \\ \dot{x}_3 = a_2 x_1 x_4 \\ \dot{x}_4 = a_3 x_1 x_3 \end{cases}$$

where

$$a_1 = -\frac{1}{c_3}; \quad a_2 = \frac{1}{c_1}; \quad a_3 = -\frac{1}{c_1}$$

Let us take now:

$$(7.2) \quad \begin{cases} x_1 = d_1 \sec h kt \\ x_3 = d_2 \operatorname{tgh} kt \\ x_4 = d_3 \sec h kt \end{cases} \quad k \in \mathbb{R}_+$$

If we plug (7.2) in (7.1) we have:

$$\begin{cases} -d_1 k = a_1 d_2 d_3 \\ d_2 k = a_2 d_1 d_3 \\ -d_3 k = a_3 d_1 d_2 \end{cases}$$

So,

$$d_1 d_2 d_3 k^3 = a_1 a_2 a_3 d_1^2 d_2^2 d_3^2$$

and then we are lead immediately to:

$$d_1^2 = -\frac{k^2}{a_2 a_3}; \quad d_2^2 = \frac{k^2}{a_1 a_3}; \quad d_3^2 = -\frac{k^2}{a_1 a_2}$$

Hence we have:

$$(7.3) \quad \begin{cases} x_1(t) = \frac{\pm k}{\sqrt{-a_2 a_3}} \sec h kt \\ x_3(t) = \frac{\pm k}{\sqrt{a_1 a_3}} \operatorname{tgh} kt \\ x_4(t) = \frac{\pm k}{\sqrt{-a_2 a_1}} \sec h kt \end{cases}$$

On the other hand we have:

$$\lim_{t \rightarrow \infty} \frac{k}{\sqrt{a_1 a_3}} \operatorname{tgh} kt = \frac{k}{\sqrt{a_1 a_3}}$$

and if we impose the condition:

$$(7.4) \quad \lim_{t \rightarrow \infty} \frac{k}{\sqrt{a_1 a_3}} \operatorname{tgh} kt = M$$

we can conclude that:

$$k = M \sqrt{a_1 a_3}$$

Therefore we have proved:

PROPOSITION (7.5). *There exists four heteroclinic orbits between the equilibrium states $(0, M, 0)$ and $(0, -M, 0)$, $M \in \mathbb{R}$, $M \neq 0$ given by (7.3) and (7.4)*

Remark (7.6). The heteroclinic orbits (7.3), (7.4) belong to the planes:

$$x_4 = \pm \sqrt{\frac{a_3}{a_1}} x_1.$$

Aknowledgements

The work of M. Puta was partially supported by the “Romanian Grant for Mathematics 2007-2009” and the “Agreement for direct cultural and scientific cooperation between the University of Rome “La Sapienza” and The West University of Timișoara.”

Received February 27, 2008

Final version received June 29, 2009

MATHEMATICS DEPARTMENT
 "POLITEHNICA" UNIVERSITY OF TIMIȘOARA
 PIAȚA VICTORIEI NR. 2
 300006-TIMIȘOARA
 ROMÂNIA
 anania.girban@gmail.com cariesanu@yahoo.com

REFERENCES

- [1] A. A. AGRACHEV, Y. L. SACHKOV, Control theory from the geometric viewpoint, Encyclopedia of Mathematical Science **87**, Control Theory and Optimization II, Springer-Verlag, 2004.
- [2] V. ARNOLD, *Conditions for nonlinear stability of stationary plane curvilinear flows of an ideal fluid*, Doklady **162** (5) (1965), 773–777.
- [3] B.H. BERMEJO AND V. FAIREN, *Simple evaluation of Casimir invariants infinite dimensional Poisson systems*, Phys. Lett. A **241**(1998), 148–154.
- [4] P. BIRTEA AND M. PUTA, *Equivalence of energy methods in stability theory*, Journ. of Math. Physics **48** (4), (2007), 81–99.
- [5] P. BIRTEA, M. PUTA AND R. M. TUDORAN, *Periodic orbits in the case of a zero eigenvalue*, C. R. Math. Acad. Sci. Paris **344** (2007), no. 12, 779–784.
- [6] W.L.CHOW, *Über Systeme von linearen partiellen Differentialgleichungen erster Ordnung*, Math. Annalen **117**, 1940-1941, 998–1005.
- [7] M. HIRSCH AND S. SMALE, Differential Equations, Dynamical Systems and Linear Algebra, Academic Press, New York, 1974.
- [8] V. JURDJEVIC, *Optimal control, geometry and mechanics*, Mathematical control theory, Edited by J. Baillieul and J. C. Willems., 227–267, Springer, New-York, 1999.
- [9] W. KAHAN, *Unconventional numerical methods for trajectory calculation*, Unpublished Lecture Notes 1993.
- [10] P.S.KRISHNAPRASAD, *Optimal control and Poisson reduction*, Technical Report 93-87, Institute for System Research, University of Maryland, 1993.
- [11] M. Puta, *An overview of some Poisson integrators*, in ENUMATH 97, 2nd European Conference on Numerical Mathematics and Advanced Applications, Heidelberg, Germany, 28 September to 3 October 1997, Edited by H. G. Bock et al., World Scientific Publishing Co., Inc., River Edge, NJ, 1998, 518–532..
- [12] M. PUTA, *Lie-Trotter formula and Poisson dynamics*, Internat. J. Bifur. Chaos Appl. Sci. Engrg. **9** (3), (1999), 555–559.
- [13] H.F. TROTTER, *On the product of operators*, Proc. Amer. Math. Soc. **10** (1959) 545–551.

A TRIGONOMETRIC-HYPERBOLIC FUNCTIONAL EQUATION AND ITS APPLICATION

JAE-YOUNG CHUNG

ABSTRACT. We consider the Hyers-Ulam stability of the *trigonometric-hyperbolic type* functional equation

$$f(x - y, s + t) = f(x, s)f(y, t) + g(x, s)g(y, t), \quad x, y \in \mathbb{R}^n, s, t > 0.$$

As an application we prove a distributional analogue of the Hyers-Ulam stability problem of the trigonometric functional equation

$$h(x - y) = h(x)h(y) + k(x)k(y), \quad x, y \in \mathbb{R}^n.$$

1. Introduction

Considering a certain class of functional equations and their Hyers-Ulam stability problems in some spaces of generalized functions such as the Schwartz tempered distributions, Fourier hyperfunctions, and so on, we need to control some modified functional equations which appear while converting given distributional version of the stability problems to classical ones. For example, stability problems of the quadratic functional equation and d'Alembert equation in the generalized functions yield the *quadratic-additive type* and *d'Alembert-exponential type* functional equations, respectively (see [5]). Likewise, if we consider a distributional version of the well known trigonometric functional equation

$$(1.1) \quad h(x - y) - h(x)h(y) - k(x)k(y) = 0, \quad x, y \in \mathbb{R}^n,$$

the following *trigonometric-hyperbolic type* functional equation appears:

$$(1.2) \quad f(x - y, s + t) = f(x, s)f(y, t) + g(x, s)g(y, t), \quad x, y \in \mathbb{R}^n, s, t > 0.$$

In this article, we first consider the equation (1.2) involving functions f, g in a more general domain and secondly we prove the Hyers-Ulam stability of the equation (1.2). As an application we prove the distributional version of Hyers-Ulam stability of the equation (1.1).

The classical stability problems of functional equations go back to 1940 when S. M. Ulam proposed the following problem [23]:

Let f be a mapping from a group G_1 to a metric group G_2 with metric $d(\cdot, \cdot)$ such that

$$d(f(xy), f(x)f(y)) \leq \varepsilon.$$

2000 *Mathematics Subject Classification*: 39B82, 46F12.

Keywords and phrases: trigonometric functional equation, d'Alembert equation, tempered distribution, Fourier hyperfunction, Gelfand-Shilov generalized function, heat kernel, Hyers-Ulam stability problem.

Then does there exist a group homomorphism L and $\delta_\epsilon > 0$ such that

$$d(f(x), L(x)) \leq \delta_\epsilon$$

for all $x \in G_1$?

This problem was solved affirmatively by D.H. Hyers [12] under the assumption that G_2 is a Banach space. In 1978, Th.M. Rassias [18] first generalized the above result and since then, stability problems of many other functional equations have been investigated by the authors such as J. A. Baker [2], [3], [4], S. Czerwik [6], G. Isac [11], S.M. Jung [13], K.W. Jun [13], H.M. Kim [13], C.G. Park [16], L. Székelyhidi [20], [21], I. Tyrala [22]. Among the results, L. Székelyhidi [20] proved the Hyers-Ulam stability of trigonometric functional equations which is very similar to the equation (1.1).

2. The general solution of equation (1.2) and its Hyers-Ulam stability

In this section generalizing the equation (1.2) we consider the equation: Let $f, g: G \times S \rightarrow \mathbb{C}$ satisfy

$$(2.1) \quad f(x - y, s + t) = f(x, s)f(y, t) + g(x, s)g(y, t), \quad x, y \in G, \quad s, t \in S.$$

where G is an abelian group and S is a semigroup which is commutative, both of which are divisible by 2, and \mathbb{C} is the field of complex numbers.

Note that a function m from a (semi)group to a field is called *exponential* provided that $m(s + t) = m(s)m(t)$.

THEOREM (2.2). *The general solutions $f, g: G \times S \rightarrow \mathbb{C}$ of the trigonometric-hyperbolic type functional equation (2.1) are either*

$$(2.3) \quad f(x, s) = \frac{1}{2}m(s)(h(x) + h(-x)), \quad g(x, s) = \frac{1}{2t}m(s)(h(x) - h(-x)),$$

where m and h are exponentials on S and G , respectively, or else

$$(2.4) \quad f(x, s) = f_0(s), \quad g(x, s) = g_0(s),$$

where (f_0, g_0) is a solution of the hyperbolic functional equation

$$(2.5) \quad f_0(s + t) = f_0(s)f_0(t) + g_0(s)g_0(t), \quad s, t \in S.$$

Proof. Replace x by y , y by x and put $t = s$ in (2.1), and compare with (2.1) to get

$$f(-y, 2s) = f(y, 2s),$$

which implies

$$(2.6) \quad f(y, s) = f(-y, s)$$

for all $(y, s) \in G \times S$, since S is divisible by 2. Replacing x, y by $-x, -y$ in (2.1), respectively, and using (2.6) we have

$$(2.7) \quad f(x - y, s + t) = f(x, s)f(y, t) + g(-x, s)g(-y, t).$$

It follows from (2.1) and (2.7) that

$$(2.8) \quad g(x, s)g(y, t) = g(-x, s)g(-y, t).$$

One can see that from (2.8) we obtain

$$(2.9) \quad g(x, s) = g(-x, s)$$

for all $(x, s) \in G \times S$, or else

$$(2.10) \quad g(x, s) = -g(-x, s)$$

for all $(x, s) \in G \times S$. If (2.9) holds, replace y by $-y$ in (2.1) to get

$$(2.11) \quad f(x + y, s + t) = f(x - y, s + t),$$

which implies $f(x, t) = f(0, t)$ for all $(x, t) \in G \times S$, since both G and S are divisible by 2. Thus, in view of (2.1), $g(x, t)$ also does not depend on $x \in G$, which gives (2.4) and (2.5).

If the equality (2.10) holds, replace y by $-y$ in (2.1) to get

$$(2.12) \quad f(x + y, s + t) = f(x, s)f(y, t) - g(x, s)g(y, t).$$

From (2.1) and (2.12) we have the d'Alembert-exponential type functional equation

$$(2.13) \quad f(x + y, s + t) + f(x - y, s + t) = 2f(x, s)f(y, t).$$

Replacing x by y , and y by x and using (2.6) and (2.13) we have

$$f(x, s)f(y, t) = f(y, s)f(x, t),$$

which implies

$$(2.14) \quad f(0, s)^{-1}f(x, s) = f(0, t)^{-1}f(x, t),$$

for all $x \in G$ and $s, t \in S_0 := \{s \in S \mid f(0, s) \neq 0\}$. If $S_0 = \emptyset$, it follows from (2.13) that $f(x, s) = 0$ for all $(x, s) \in G \times S$, which implies the trivial case $f = g \equiv 0$. If $S_0 \neq \emptyset$, we may write

$$(2.15) \quad F(x) := f(0, s)^{-1}f(x, s),$$

for all $x \in G, s \in S_0$. Put $x = y = 0$ in (2.13) to get

$$(2.16) \quad f(0, s + t) = f(0, s)f(0, t)$$

for all $s, t \in S$. Now, for any $s \notin S_0$, let $s = 2u$. Then it follows from (2.16) that $u \notin S_0$. Put $y = 0, s = t = u$ in (2.13) to get

$$(2.17) \quad f(x, s) = f(x, 2u) = f(x, u)f(0, u) = 0,$$

for all $x \in G, s \notin S_0$. Thus it follows from (2.15) and (2.17) that

$$(2.18) \quad f(x, s) = f(0, s)F(x),$$

for all $(x, s) \in G \times S$. Now choose $s_0 \in S_0$, and divide (2.13) by $f(0, s_0)^2 = f(0, 2s)$ and put $s = t = s_0$ to get

$$(2.19) \quad F(x + y) + F(x - y) = 2F(x)F(y), \quad x, y \in G.$$

Therefore, we have proved that F satisfies the classical d'Alembert functional equation and due to J. A. Baker [1] p. 222 the general solution of the equation (2.19) is given by

$$(2.20) \quad F(x) = \frac{1}{2}(h(x) + h(-x)),$$

where $h(x + y) = h(x)h(y)$ for all $x, y \in G$. Thus we have

$$(2.21) \quad f(x, s) = \frac{1}{2}m(s)(h(x) + h(-x)),$$

with $m(s) = f(0, s)$. Finally, putting (2.21) in (2.1) we have

$$g(x, s)g(y, t) = -\frac{1}{4}m(s)m(t)(h(x) - h(-x))(h(y) - h(-y)).$$

Consequently we obtain

$$(2.22) \quad g(x, s) = \pm \frac{1}{2i}m(s)(h(x) - h(-x)).$$

The minus sign in (2.22) disappears by substitution of $h(x)$ by $h(-x)$. By a straightforward calculation one may check that f and g given by (2.2) satisfy (2.1). This completes the proof. \square

Remark. The author would like to know if the above result holds true without the assumptions that G and S are divisible by 2.

As a consequence of the above result we have the following.

COROLLARY (2.23). *Let $f, g: \mathbb{R}^n \times (0, \infty) \rightarrow \mathbb{C}$ be continuous functions satisfying the equation*

$$(2.24) \quad f(x - y, s + t) = f(x, s)f(y, t) + g(x, s)g(y, t), \quad x, y \in \mathbb{R}^n, s, t > 0.$$

Then the solutions (f, g) are given by the following :

- i) $f = g = 0$,
- ii) $f(x, s) = \frac{e^{ps}}{1+\lambda^2}, g(x, s) = \frac{\lambda e^{ps}}{1+\lambda^2}, \lambda^2 \neq -1$,
- iii) $f(x, s) = (qs + 1)e^{ps}, g(x, s) = \pm iqs e^{ps}$,
- iv) $f(x, s) = e^{ps}(\cos qs + \lambda \sin qs), g(x, s) = \pm i\sqrt{1 + \lambda^2}e^{ps} \sin qs$,
- v) $f(x, s) = e^{ps} \cosh(a \cdot x), g(x, s) = e^{ps} \sinh(a \cdot x)$,

where $p, q, \lambda \in \mathbb{C}, a \in \mathbb{C}^n$.

Proof. It is well known in [1] that the continuous solutions of the equation (2.5) are given by i), ii), iii) and iv). In view of (2.2), if $f(x, s)$ and $g(x, s)$ are continuous and are of the form (2.2) then $m(s)$ and $h(x)$ are continuous and hence $m(s) = e^{ps}, h(x) = e^{a \cdot x}$ for some $p \in \mathbb{C}, a \in \mathbb{C}^n$, which gives v). This completes the proof. \square

Now we consider the stability of the following trigonometric-hyperbolic functional equation.

THEOREM (2.25). *Let $M > 0$ and let $f, g: \mathbb{R}^n \times (0, \infty) \rightarrow \mathbb{C}$ be continuous functions satisfying the inequality*

$$(2.26) \quad |f(x - y, s + t) - f(x, s)f(y, t) - g(x, s)g(y, t)| \leq M, \quad x, y \in \mathbb{R}^n, s, t > 0.$$

Then (f, g) satisfies one of the following:

- i) $f(x, s)$ and $g(x, s)$ are bounded on the strip $\mathbb{R}^n \times (0, 1)$,
- ii) $f(x, s) = e^{ps} \cosh(a \cdot x), g(x, s) = e^{ps} \sinh(a \cdot x)$,

where $p \in \mathbb{C}, a \in \mathbb{C}^n$.

Proof. Following the same approach as in [20] we can verify that either there exist $\mu, \nu \in \mathbb{C}$, not both zero, and $L > 0$ such that

$$(2.27) \quad |\mu f(x, s) - \nu g(x, s)| \leq L, \quad x \in \mathbb{R}^n, s > 0$$

or else

$$(2.28) \quad f(x - y, s + t) = f(x, s)f(y, t) + g(x, s)g(y, t), \quad x, y \in \mathbb{R}^n, s, t > 0.$$

If the equation (2.28) holds, then by Corollary (2.23) the solutions (f, g) satisfies (i) or (ii). Now we consider the case where (2.27) holds. If g is bounded, then $f(x - y, s + t) - f(x, s)f(y, t)$ is bounded, which implies $f(x, s)$ is bounded in $\mathbb{R}^n \times (0, 1)$. If g is unbounded, then f is also unbounded, hence $\mu \neq 0$ and $\nu \neq 0$. Thus we can write

$$(2.29) \quad f = \lambda g + B$$

for some $\lambda \neq 0$ and a bounded function B . Putting (2.29) in (2.26) it is easy to see that

$$(x, s) \rightarrow g(x + y, s + t) - \lambda^{-1}((\lambda^2 + 1)g(-y, t) + \lambda B(-y, t))g(x, s)$$

is a bounded function for each $y \in \mathbb{R}^n, t > 0$. Using Theorem 5.2 of [12] we have

$$(2.30) \quad \lambda^{-1}((\lambda^2 + 1)g(y, t) + \lambda B(y, t)) = m(y, t)$$

for an exponential m . Thus if $\lambda^2 \neq -1$ we have

$$g = \frac{\lambda(m - B)}{\lambda^2 + 1}, \quad f = \frac{\lambda^2 m + B}{\lambda^2 + 1}.$$

From (2.29) and the continuity of f and g we have $m(y, t) = e^{a \cdot y + bt}$. Now it follows from (2.26) that $|f(x, s) - f(-x, s)| \leq 2M$ and hence we obtain $a = 0$. Thus the case (i) follows. If $\lambda^2 = -1$ it follows from (2.29) and (2.30)

$$(2.31) \quad g = \pm i(f - m)$$

for some bounded exponential function m . Put (2.31) in (2.26) to get

$$(2.32) \quad |f(x - y, s + t) - f(x, s)m(y, t) - f(y, t)m(x, s)| \leq M$$

for all $x, y \in \mathbb{R}^n, t, s > 0$. Since m is a bounded exponential we obtain $m(x, s) = e^{a \cdot x + bs}$ for some $a \in i\mathbb{R}^n, b \in \mathbb{C}$ with $\Re b < 0$. Put $y = x, t = s$ in (2.32) and use the triangle inequality to get

$$(2.33) \quad |f(x, s)| \leq \frac{1}{2}e^{-(\Re b)s}(M + |f(0, 2s)|).$$

It follows from the inequality (2.32) together with the continuity of f that $f(0, s)$ is bounded in $(0, 1)$. Thus $f(x, s)$ is bounded in $\mathbb{R}^n \times (0, 1)$ and so is g . Thus the case (i) follows. This completes the proof. □

3. Application to Hyers-Ulam stability problem of (1.1) in Schwartz distributions

As an application we consider a distributional version of the following Hyers-Ulam stability problem of the trigonometric functional equation

$$(3.1) \quad |h(x - y) - h(x)h(y) - k(x)k(y)| \leq M$$

in the space $S'(\mathbb{R}^n)$ of Schwartz tempered distributions, the space $\mathcal{F}'(\mathbb{R}^n)$ of Fourier hyperfunctions and the space $S_{1/2}^{1/2}(\mathbb{R}^n)$ of Gelfand generalized functions. For a theory of Schwartz tempered distributions we refer the reader to [8, 9, 19]. Here we briefly introduce the spaces of Gelfand generalized

functions and Fourier hyperfunctions. Here we use the following notation: $|x| = \sqrt{x_1^2 + \dots + x_n^2}$, $|\alpha| = \alpha_1 + \dots + \alpha_n$, $\alpha! = \alpha_1! \dots \alpha_n!$, $x^\alpha = x_1^{\alpha_1} \dots x_n^{\alpha_n}$ and $\partial^\alpha = \partial_1^{\alpha_1} \dots \partial_n^{\alpha_n}$, for $x = (x_1, \dots, x_n) \in \mathbb{R}^n$, $\alpha = (\alpha_1, \dots, \alpha_n) \in \mathbb{N}_0^n$, where \mathbb{N}_0 is the set of non-negative integers and $\partial_j = \frac{\partial}{\partial x_j}$.

Definition (3.2). [8] For given $r, s \geq 0$ we denote by \mathcal{S}_r^s or $\mathcal{S}_r^s(\mathbb{R}^n)$ the space of all infinitely differentiable functions $\varphi(x)$ on \mathbb{R}^n such that there exist positive constants h and k satisfying

$$(3.3) \quad \|\varphi\|_{h,k} := \sup_{x \in \mathbb{R}^n, \alpha, \beta \in \mathbb{N}_0^n} \frac{|x^\alpha \partial^\beta \varphi(x)|}{h^{|\alpha|} k^{|\beta|} \alpha! r \beta!^s} < \infty.$$

The topology on the space \mathcal{S}_r^s is defined by the seminorms $\|\cdot\|_{h,k}$ given by (3.3) and the elements of the dual space \mathcal{S}'_r^s of \mathcal{S}_r^s are called *Gelfand-Shilov generalized functions*. In particular, we denote \mathcal{S}'_1^1 by \mathcal{F}' and call its elements *Fourier hyperfunctions*.

It is known that if $r > 0$ and $0 \leq s < 1$, the space $\mathcal{S}_r^s(\mathbb{R}^n)$ consists of all infinitely differentiable functions $\varphi(x)$ on \mathbb{R}^n that can be extended to an entire function on \mathbb{C}^n satisfying

$$(3.4) \quad |\varphi(x + iy)| \leq C \exp(-a|x|^{1/r} + b|y|^{1/(1-s)})$$

for some $a, b > 0$. It is well known that the following topological inclusions hold:

$$\mathcal{S}'_{1/2} \hookrightarrow \mathcal{F} \hookrightarrow \mathcal{S}, \quad \mathcal{S}' \hookrightarrow \mathcal{F}' \hookrightarrow \mathcal{S}'_{1/2}.$$

As in [5] we generalized the inequality (3.1) involving generalized functions u, v as

$$(3.5) \quad u \circ B - u \otimes u - v \otimes v \in L^\infty(\mathbb{R}^{2n})$$

where $B(x, y) = x - y$, $x, y \in \mathbb{R}^n$ and \otimes denotes the tensor product of generalized functions.

We denote by $E_t(x)$ the n -dimensional heat kernel

$$(3.6) \quad E_t(x) = (4\pi t)^{-n/2} \exp(-|x|^2/4t), \quad t > 0.$$

Let $u \in \mathcal{S}'_{1/2}$. Then its *Gauss transform* $f(x, t) := (u * E_t)(x) = \langle u, E_t(x - y) \rangle$ is a C^∞ -solution of the heat equation

$$(\Delta - \partial/\partial t)f(x, t) = 0$$

in $\{(x, t) : x \in \mathbb{R}^n, t > 0\}$. Also $(u * E_t)(x) \rightarrow u$ as $t \rightarrow 0^+$ in the sense of generalized functions.

LEMMA (3.7). [24] *Let $f(x, t)$ be a solution of the heat equation satisfying*

$$|f(x, t)| \leq M, \quad x \in \mathbb{R}^n, \quad t \in (0, 1).$$

Then f can be written as

$$f(x, t) = (f_0 * E_t)(x) = \int f_0(y) E_t(x - y) dy$$

for some bounded measurable function f_0 defined in \mathbb{R}^n .

THEOREM (3.8). *Let $u, v \in S'_{1/2}$ satisfy (3.5). Then u and v satisfy one of the followings:*

- i) u and v are bounded measurable functions,*
- ii) $u = \cosh(a \cdot x), v = \sinh(a \cdot x),$*

where $a \in \mathbb{C}^n$.

Proof. Convoluting with $E_s(x)E_t(y)$ in (3.4), in view of the semigroup property $(E_s * E_t)(x) = E_{s+t}(x)$ of the heat kernel, we have for some $M > 0$,

$$(3.9) \quad |f(x - y, s + t) - f(x, s)f(y, t) - g(x, s)g(y, t)| \leq M$$

for all $x, y \in \mathbb{R}^n, s, t > 0$, where $f(x, t), g(x, t)$ are the Gauss transforms of u and v . Now we apply Theorem 2.3. If $f(x, t)$ and $g(x, t)$ are bounded in the strip $\mathbb{R}^n \times (0, 1)$, letting $t \rightarrow 0^+$ we have the case (i) by Lemma 3.2. If $f(x, t) = e^{pt} \cosh(a \cdot x), g(x, t) = e^{pt} \sinh(a \cdot x)$, letting $t \rightarrow 0^+$ we get the case (ii). This completes the proof. \square

Taking the growth of $u = \cosh(a \cdot x), v = \sinh(a \cdot x)$ as $|x| \rightarrow \infty$ into account we obtain $a = ia'$ for some $a' \in \mathbb{R}^n$ provided that $u, v \in \mathcal{F}'$. Thus we have the following.

COROLLARY (3.10). *Let $u, v \in \mathcal{S}'$ or $u, v \in \mathcal{F}'$ satisfy (3.4). Then u and v are bounded measurable functions.*

Acknowledgments

This work was supported by the Korean Research Foundation Grant funded by the Korean Government (MOEHRD, Basic Research Promotion Fund) (KRF-2006-521-C00010).

The author would like to express his sincere gratitude to the referee for many valuable comments and corrections.

Received February 28, 2007

Final version received May 6, 2009

DEPARTMENT OF MATHEMATICS,
KUNSAN NATIONAL UNIVERSITY,
KUNSAN 573-701, REPUBLIC OF KOREA
jychung@kunsan.ac.kr

REFERENCES

- [1] J. ACZÉL and J. DHOMBRES, *Functional equations in several variables*, Cambridge University Press, New York-Sydney, 1989.
- [2] J. A. BAKER, *The stability of cosine functional equation*, Proc. Amer. Math. Soc. **80** (1980), 411–416.
- [3] J. A. BAKER, *Functional equations, tempered distributions, and Fourier transforms*, Trans. Amer. Math. Soc. **315** (1989), 57–68.
- [4] J. A. BAKER, *Distributional methods for functional equations*, Aequationes Math. **62** (2001), 136–142.
- [5] J. Y. CHUNG, *A distributional version of functional equations and their stabilities*, Nonlinear Anal. **62** (2005), 1037–1051.
- [6] S. CZERWIK, *Stability of Functional Equations of Ulam-Hyers-Rassias Type*, Hadronic Press, Inc., Palm Harbor, Florida (2003).

- [7] I. FENYÖ, *Über eine Lösungsmethode gewisser Funktionalgleichungen*, Acta Math. Acad. Sci. Hungar. **7** (1956), 383–396.
- [8] I. M. GELFAND and G. E. SHILOV, *Generalized functions II*, Academic Press, New York, 1968.
- [9] L. HÖRMANDER, *The analysis of linear partial differential operators I*, Springer-Verlag, Berlin-New York, 1983.
- [10] D. H. HYERS and TH. M. RASSIAS, *Approximate homomorphisms*, Aequationes Math. **44** (1992), 125–153.
- [11] D. H. HYERS, G. ISAC and TH. M. RASSIAS, *Stability of functional equations in several variables*, Birkhäuser Boston, Inc., Boston, MA, 1998.
- [12] D. H. HYERS, *On the stability of the linear functional equations*, Proc. Nat. Acad. Sci. USA **27** (1941) 222–224.
- [13] S. M. JUNG, *Hyers-Ulam-Rassias Stability of Functional Equations in Mathematical Analysis*, Hadronic Press, Inc., Palm Harbor, Florida, 2001.
- [14] K. W. JUN, H. M. KIM, *Stability problem for Jensen-type functional equations of cubic mappings*, Acta Mathematica Sinica, English Series, **22** (6) (2006), 1781–1788.
- [15] PL. KANNAPPAN, *The functional equation $f(xy) + f(xy^{-1}) = 2f(x)f(y)$ for groups*, Proc. Amer. Math. Soc. **19** (1968) 69–74
- [16] C. G. PARK, *Hyers-Ulam-Rassias stability of homomorphisms in quasi-Banach algebras*, Bull. Sci. math. **132** (2008) 87–96.
- [17] TH. M. RASSIAS, *On the stability of functional equations in Banach spaces*, J. Math. Anal. Appl. **251**(2000), 264–284.
- [18] TH. M. RASSIAS, *On the stability of linear mapping in Banach spaces*, Proc. Amer. Math. Soc. **72** (1978) 297–300.
- [19] L. SCHWARTZ, *Théorie des distributions*, Hermann, Paris, (1966).
- [20] L. SZÉKELYHIDI, *The stability of sine and cosine functional equations*, Proc. Amer. Math. Soc. **110** (1990) 109–115.
- [21] L. SZÉKELYHIDI, *The stability of d'Alembert type functional equations*, Acta Sci. Math. Szeged. **44** (1982c) 313–320.
- [22] I. TYRALA, *The stability of d'Alembert's functional equation*, Aequationes Math. **69** (2005) 250–256.
- [23] S. M. ULAM, *A collection of mathematical problems*, Interscience Publ., New York, 1960.
- [24] D. V. WIDDER, *The heat equation*, Academic Press, New York, 1975.

ORTHOGONAL POLYNOMIALS ON RAYS: CHRISTOFFEL'S FORMULA

ABDON E. CHOQUE RIVERO AND SERGEY M. ZAGORODNYUK

ABSTRACT. Christoffel's formula is an important property of orthogonal polynomials on the real line. In this paper we obtain a generalization of this formula in the case of orthogonal polynomials on rays with a non-negative matrix measure. Using this generalization we get explicit formulas for a new system of orthogonal polynomials. Some properties of the corresponding kernel polynomials are obtained. Relations between the recursion coefficients of the original polynomials and the recursion coefficients of the polynomials corresponding to the perturbed measure are derived.

1. Introduction

Let $\alpha(x)$ be a non-decreasing function on $[a, b]$, $-\infty \leq a < b \leq +\infty$, with finite power moments:

$$(1.1) \quad \int_a^b x^n d\alpha(x) < \infty, \quad \text{for all } n \in \mathbb{Z}_+.$$

Suppose that $\alpha(x)$ has an infinite number of points of increase. Applying the Gram-Schmidt orthogonalization to the monomial basis $1, \lambda, \lambda^2, \dots$, one obtains the well-known real orthogonal polynomials [13]. These polynomials $\{p_n(\lambda)\}_{n \in \mathbb{Z}_+}$ satisfy the orthonormality relations

$$(1.2) \quad \int_a^b p_n(x)p_m(x)d\alpha(x) = \delta_{n,m}, \quad n, m \in \mathbb{Z}_+.$$

Among their numerous properties there is the following important fact, known as Christoffel's formula [3],[13], which is a representation of polynomials that are orthogonal with respect to a polynomial perturbation of a positive Borel measure.

THEOREM (1.3). *Let $\{p_n(\lambda)\}_{n \in \mathbb{Z}_+}$ be an orthonormal system of polynomials on $[a, b]$ with respect to $d\alpha(x)$. Let*

$$(1.4) \quad \rho(x) = c(x - x_1)(x - x_2) \dots (x - x_l), \quad c \neq 0,$$

be a non-negative polynomial of degree l on $[a, b]$.

2000 *Mathematics Subject Classification:* 42C05, 33C45.

Keywords and phrases: Orthogonal polynomials; Christoffel's formula.

Supported by Project 25551 CONACYT, México; SNI, Project CIC of UMSNH, México.

Let polynomials $\{q_n(\lambda)\}_{n \in \mathbb{Z}_+}$ be defined by the following determinant

$$(1.5) \quad \rho(x)q_n(x) = \begin{vmatrix} p_n(x) & p_{n+1}(x) & \dots & p_{n+l}(x) \\ p_n(x_1) & p_{n+1}(x_1) & \dots & p_{n+l}(x_1) \\ \dots & \dots & \dots & \dots \\ p_n(x_l) & p_{n+1}(x_l) & \dots & p_{n+l}(x_l) \end{vmatrix}.$$

Then the polynomials $\{q_n(\lambda)\}_{n \in \mathbb{Z}_+}$ are orthogonal with respect to $\rho(x)d\alpha(x)$.

If the zero x_k has multiplicity $m > 1$, then the corresponding rows in the determinant (1.5) should be replaced by the derivatives of degree $0, 1, 2, \dots, m-1$ of polynomials $p_n(x), p_{n+1}(x), \dots, p_{n+l}(x)$ at the point $x = x_k$.

In particular, from Christoffel’s formula one can get explicit formulas for new orthogonal systems of polynomials using already known systems. For further details on determinants of orthogonal polynomials, we refer to Karlin and McGregor [9].

The Christoffel formula (1.5) when $\rho(x)$ is a linear polynomial is equivalent to the three term recurrence relation satisfied by standard orthogonal polynomials, see [2]. On the other hand, some numerical implementation of the Christoffel formula has been analyzed in [8].

Define the following polynomials (*kernel polynomials* [3]):

$$(1.6) \quad K_n(x_0, x) = \sum_{j=0}^n \overline{p_j(x_0)} p_j(x), \quad x, x_0 \in \mathbb{C}, \quad n \in \mathbb{Z}_+.$$

These polynomials have the following *reproducing property* (which follows directly from orthonormality relations (1.2)):

$$(1.7) \quad \int_a^b K_n(t, x) \omega(t) d\alpha(t) = \omega(x),$$

for any polynomial $\omega(x)$, $\deg \omega \leq n$. The following two results are proven in [13]:

THEOREM (1.8). *Let x_0 be an arbitrary complex number and $\phi(x)$ be an arbitrary complex polynomial, $\deg \phi \leq n$, normalized in the following way:*

$$(1.9) \quad \int_a^b |\phi(x)|^2 d\alpha(x) = 1.$$

The maximum of $|\phi(x_0)|^2$ is given by the polynomials

$$(1.10) \quad \phi(x) = \varepsilon \{K_n(x_0, x_0)\}^{-\frac{1}{2}} K_n(x_0, x), \quad |\varepsilon| = 1, \quad n \in \mathbb{Z}_+.$$

The maximum itself is $K_n(x_0, x_0)$.

THEOREM (1.11). *Let a and x_0 be finite and $x_0 \leq a$. Then the polynomials $\{K_n(x_0, x)\}_{n \in \mathbb{Z}_+}$ are orthogonal with respect to $(x - x_0)d\alpha$.*

For $n \in \mathbb{N}$, we denote by $\mathbb{C}_{n \times n}$ the set of all $n \times n$ matrices with complex coefficients and by $\mathbb{C}_{n \times n}^{\geq}$ the set of all positive semi-definite Hermitian matrices from $\mathbb{C}_{n \times n}$. The letter \mathbb{P} stands for the set of all complex polynomials. Let

$$L_N = \{\lambda \in \mathbb{C} : \lambda^N - \bar{\lambda}^N = 0\} = \{\lambda \in \mathbb{C} : \lambda^N \in \mathbb{R}\}, \quad N \in \mathbb{N}.$$

It can easily be seen that L_N is a set of $2N$ radial rays or a pencil of N lines and

$$(1.12) \quad L_N = \bigcup_{k=0}^{2N-1} \{x\widehat{\varepsilon}^k, x \geq 0\} = \bigcup_{k=0}^{N-1} \{x\widehat{\varepsilon}^k, x \in \mathbb{R}\},$$

where $\widehat{\varepsilon} = \cos \frac{\pi}{N} + i \sin \frac{\pi}{N}$ is a primitive root of unity of order $2N$. Set

$$(1.13) \quad L_{N,k} := \{x\widehat{\varepsilon}^k, x \geq 0\}, \quad k = 0, 1, \dots, 2N - 1.$$

Let $M(\lambda)$ be a $\mathbb{C}_{N \times N}$ -valued function on $L_N \setminus \{0\}$ which is non-decreasing on each ray $L_{N,k} \setminus \{0\}$, $k = 0, 1, \dots, 2N - 1$, in the direction from 0 to ∞ . This means that $M(\lambda_2) - M(\lambda_1) \geq 0$, if $\lambda_1, \lambda_2 \in L_{N,k} \setminus \{0\}$ and $|\lambda_2| \geq |\lambda_1|$ ($k = 0, 1, \dots, 2N - 1$).

Suppose that the function $M(\lambda)$ satisfies

$$(1.14) \quad \int_{L_N} (\lambda^n, (\lambda\varepsilon)^n, (\lambda\varepsilon^2)^n, \dots, (\lambda\varepsilon^{N-1})^n) dM(\lambda) \overline{\begin{pmatrix} \lambda^n \\ (\lambda\varepsilon)^n \\ \vdots \\ (\lambda\varepsilon^{N-1})^n \end{pmatrix}} < \infty, \quad n \in \mathbb{Z}_+,$$

where $\varepsilon = \cos \frac{2\pi}{N} + i \sin \frac{2\pi}{N}$ is a primitive root of unity of order N . Here and in the sequel the integral over L_N will be understood as a sum of integrals over each ray $L_{N,k}$, $k = 0, 1, \dots, 2N - 1$. The integral over $L_{N,k}$ ($k = 0, 1, \dots, 2N - 1$) is understood as improper at zero, i.e.

$$\int_{L_{N,k}} \dots = \lim_{\delta \rightarrow +0} \int_{L_{N,k} \setminus U_\delta(0)} \dots,$$

where $U_\delta(0) = \{\lambda \in \mathbb{C} : |\lambda| < \delta\}$.

Let $A \in \mathbb{C}_{N \times N}^{\geq}$. Define the following functional:

$$(1.15) \quad \begin{aligned} \sigma(u, v) = & \int_{L_N} (u(\lambda), u(\lambda\varepsilon), u(\lambda\varepsilon^2), \dots, u(\lambda\varepsilon^{N-1})) dM(\lambda) \overline{\begin{pmatrix} v(\lambda) \\ v(\lambda\varepsilon) \\ \vdots \\ v(\lambda\varepsilon^{N-1}) \end{pmatrix}} \\ & + (u(0), u'(0), u''(0), \dots, u^{(N-1)}(0)) A \overline{\begin{pmatrix} v(0) \\ v'(0) \\ \vdots \\ v^{(N-1)}(0) \end{pmatrix}}, \quad u, v \in \mathbb{P}. \end{aligned}$$

It follows from (1.14) that it is well defined. The functional σ is bilinear and it is not hard to see that

$$(1.16) \quad \sigma(\lambda^N u(\lambda), v(\lambda)) = \sigma(u(\lambda), \lambda^N v(\lambda)), \quad u, v \in \mathbb{P};$$

$$(1.17) \quad \overline{\sigma(u, v)} = \sigma(v, u), \quad u, v \in \mathbb{P};$$

$$(1.18) \quad \sigma(u, u) \geq 0, \quad u \in \mathbb{P}.$$

We assume that the functional σ is positive definite in the usual sense:

$$(1.19) \quad \sigma(u, u) > 0,$$

for all non-zero $u \in \mathbb{P}$.

Applying the Gram-Schmidt orthogonalization with respect to the functional σ for the sequence $1, \lambda, \lambda^2, \dots, \lambda^n, \dots$, we obtain a sequence of orthonormal polynomials $\{p_n(\lambda)\}_{n=0}^\infty$ (p_n has degree n and a positive leading coefficient), that is,

$$(1.20) \quad \int_{L_N} (p_n(\lambda), p_n(\lambda\varepsilon), p_n(\lambda\varepsilon^2), \dots, p_n(\lambda\varepsilon^{N-1})) dM(\lambda) \begin{pmatrix} p_m(\lambda) \\ p_m(\lambda\varepsilon) \\ \vdots \\ p_m(\lambda\varepsilon^{N-1}) \end{pmatrix} + (p_n(0), p_n'(0), p_n''(0), \dots, p_n^{(N-1)}(0)) A \begin{pmatrix} p_m(0) \\ p_m'(0) \\ \vdots \\ p_m^{(N-1)}(0) \end{pmatrix} = \delta_{n,m}, \quad n, m \in \mathbb{Z}_+.$$

These polynomials satisfy the following recurrence relation:

$$(1.21) \quad \sum_{j=1}^N (\overline{\alpha_{k-j,j}} p_{k-j}(\lambda) + \alpha_{k,j} p_{k+j}(\lambda)) + \alpha_{k,0} p_k(\lambda) = \lambda^N p_k(\lambda), \quad k \in \mathbb{Z}_+,$$

where $\alpha_{m,n} \in \mathbb{C}$, $m, n \in \mathbb{Z}_+$ such that $\alpha_{m,N} > 0$, $\alpha_{m,0} \in \mathbb{R}$, and those $\alpha_{m,n}, p_k$ which appear here with negative indices are equal to zero.

Systems of polynomials $\{p_n(\lambda)\}_{n=0}^\infty$ which satisfy the recurrence relation (1.21) with *real* coefficients $\alpha_{m,n}$ were first studied by Duran [4] in 1993, following a suggestion of Marcellán. Duran showed that the polynomials are orthogonal with respect to a bilinear functional $B(\cdot, \cdot)$. He obtained an integral representation for the functional with some measure. In 1995, he showed in [5] that the measure can be chosen to be positive. In the same year, Duran and Van Assche studied the case of the *complex* coefficients in the relation (1.21), see [7]. From their results (see [7, Theorem]) it is easy to derive an integral representation of B in the general case. In 2003, the second author obtained another integral representation for the functional B , see [15]. This representation is exactly (1.15). Thus, we can say that orthonormality relations (1.20) and difference relation (1.21) are *equivalent*.

Other properties of polynomials satisfying high-order recurrence relation (1.21) can be found in [6],[14],[10],[16]. For some properties of the corresponding kernel polynomials, see [5].

The aim of our present investigation is to extend the above mentioned results for the orthogonal polynomials on $[a, b]$ to the case of orthogonal polynomials on radial rays. As an application, we obtain explicit formulas for a new system of orthogonal polynomials.

Notations. Besides the definitions given above, we denote as usual the sets of real numbers, complex numbers, positive integers, integers and non-negative integers by $\mathbb{R}, \mathbb{C}, \mathbb{N}, \mathbb{Z}, \mathbb{Z}_+$, respectively.

2. A generalization of Christoffel's formula and auxiliary results

Let $M(\lambda)$ and A be defined as in the introduction with the properties stated there. Let $\{p_n(\lambda)\}_{n=0}^\infty$ (p_n has degree n and a positive leading coefficient) be a sequence of orthonormal polynomials which satisfies (1.20). Consider an interval $[a, b]$, $-\infty \leq a < b \leq +\infty$, such that

$$(2.1) \quad \int_{L_N} (p(\lambda), p(\lambda\varepsilon), p(\lambda\varepsilon^2), \dots, p(\lambda\varepsilon^{N-1})) dM(\lambda) \begin{pmatrix} q(\lambda) \\ q(\lambda\varepsilon) \\ \vdots \\ q(\lambda\varepsilon^{N-1}) \end{pmatrix} \\ = \int_{\{z \in \mathbb{C}: z^N \in [a, b]\}} (p(\lambda), p(\lambda\varepsilon), p(\lambda\varepsilon^2), \dots, p(\lambda\varepsilon^{N-1})) dM(\lambda) \begin{pmatrix} q(\lambda) \\ q(\lambda\varepsilon) \\ \vdots \\ q(\lambda\varepsilon^{N-1}) \end{pmatrix},$$

for all polynomials $p, q \in \mathbb{P}$. In other words, we exclude, if possible, a part of the integral over L_N which has no influence on the functional $\sigma(u, v)$.

Let $\rho(x) \in \mathbb{P}$ be positive on $[a, b]$, where $\deg \rho = l$, $l \in \mathbb{N}$. Suppose that it can be written in the form (1.4) with $c, x_j \in \mathbb{R}$, $c \neq 0$ and that its zeros are simple.

$$(2.2) \quad \rho(0) > 0.$$

Then we have

$$(2.3) \quad \rho(\lambda^N) = c(\lambda^N - x_1)(\lambda^N - x_2) \dots (\lambda^N - x_l) = c \prod_{j=1}^l \prod_{k=1}^N (\lambda - x_{j,k}),$$

where

$$(2.4) \quad \mathcal{X}_j := \{x_{j,k}\}_{k=1}^N$$

is a set of all N -th roots $\sqrt[N]{x_j}$, $j = 1, 2, \dots, l$.

Set

$$(2.5) \quad D_n(\lambda) := \begin{vmatrix} p_n(\lambda) & p_{n+1}(\lambda) & \dots & p_{n+Nl}(\lambda) \\ p_n(x_{1,1}) & p_{n+1}(x_{1,1}) & \dots & p_{n+Nl}(x_{1,1}) \\ p_n(x_{1,2}) & p_{n+1}(x_{1,2}) & \dots & p_{n+Nl}(x_{1,2}) \\ \dots & \dots & \dots & \dots \\ p_n(x_{1,N}) & p_{n+1}(x_{1,N}) & \dots & p_{n+Nl}(x_{1,N}) \\ \vdots & \vdots & \ddots & \vdots \\ p_n(x_{l,1}) & p_{n+1}(x_{l,1}) & \dots & p_{n+Nl}(x_{l,1}) \\ p_n(x_{l,2}) & p_{n+1}(x_{l,2}) & \dots & p_{n+Nl}(x_{l,2}) \\ \dots & \dots & \dots & \dots \\ p_n(x_{l,N}) & p_{n+1}(x_{l,N}) & \dots & p_{n+Nl}(x_{l,N}) \end{vmatrix}, \quad n \in \mathbb{Z}_+, \lambda \in \mathbb{C};$$

$$(2.6) \quad d_n := \begin{pmatrix} p_n(x_{1,1}) & p_{n+1}(x_{1,1}) & \dots & p_{n+Nl-1}(x_{1,1}) \\ p_n(x_{1,2}) & p_{n+1}(x_{1,2}) & \dots & p_{n+Nl-1}(x_{1,2}) \\ \dots & \dots & \dots & \dots \\ p_n(x_{1,N}) & p_{n+1}(x_{1,N}) & \dots & p_{n+Nl-1}(x_{1,N}) \\ \vdots & \vdots & \ddots & \vdots \\ p_n(x_{l,1}) & p_{n+1}(x_{l,1}) & \dots & p_{n+Nl-1}(x_{l,1}) \\ p_n(x_{l,2}) & p_{n+1}(x_{l,2}) & \dots & p_{n+Nl-1}(x_{l,2}) \\ \dots & \dots & \dots & \dots \\ p_n(x_{l,N}) & p_{n+1}(x_{l,N}) & \dots & p_{n+Nl-1}(x_{l,N}) \end{pmatrix}, \quad n \in \mathbb{Z}_+, \lambda \in \mathbb{C}.$$

LEMMA (2.7). *Let d_n be defined as in (2.6). Then $d_n \neq 0$ for all $n \in \mathbb{Z}_+$.*

Proof. We proceed as in the classical case [13, Chapter 2.5]. Suppose that $d_k = 0$ for $k \in \mathbb{Z}_+$. Then there exist complex numbers $\xi_k, k = n, n + 1, \dots, n + Nl - 1$, not all zero, such that

$$(2.8) \quad \mathcal{Q}(\lambda) := \sum_{k=n}^{n+Nl-1} \xi_k p_k(\lambda) = 0, \quad \lambda \in \mathcal{X}_j, \quad j = 1, 2, \dots, l.$$

This yields $\mathcal{Q}(\lambda) = \rho(\lambda^N)G(\lambda)$, where $G(\lambda) \in \mathbb{P}, \deg G \leq n - 1$. Using the orthonormality of polynomials p_k and relation (2.8) we get

$$\sigma(\mathcal{Q}(\lambda), p_m(\lambda)) = 0, \quad m = 0, 1, \dots, n - 1,$$

where $\sigma(u, v)$ is the functional from Equation (1.15). Therefore $\sigma(\mathcal{Q}(\lambda), q(\lambda)) = 0$, for an arbitrary $q \in \mathbb{P}$ with $\deg q \leq n - 1$. In particular, we obtain $\sigma(\mathcal{Q}(\lambda), G(\lambda)) = \sigma(\rho(\lambda^N)G(\lambda), G(\lambda)) = 0$. This means that

$$(2.9) \quad \int_{L_N} \rho(\lambda^N)(G(\lambda), G(\lambda\varepsilon), G(\lambda\varepsilon^2), \dots, G(\lambda\varepsilon^{N-1}))dM(\lambda) \begin{pmatrix} G(\lambda) \\ G(\lambda\varepsilon) \\ \vdots \\ G(\lambda\varepsilon^{N-1}) \end{pmatrix} + (\rho(\lambda^N)G(\lambda), (\rho(\lambda^N)G(\lambda))', \dots, (\rho(\lambda^N)G(\lambda))^{(N-1)})A \begin{pmatrix} G(\lambda) \\ G'(\lambda) \\ \vdots \\ G^{(N-1)}(\lambda) \end{pmatrix} \Big|_{\lambda=0} = 0.$$

Let \hat{A} denote the second term on the left hand side of (2.9). Suppose first that A is not the zero matrix. Then we can write

$$(2.10) \quad \rho(\lambda^N) = c_0 + \lambda^N r(\lambda), \quad r \in \mathbb{P}.$$

Therefore

$$\hat{A} = (c_0 G(\lambda), (c_0 G(\lambda))', \dots, (c_0 G(\lambda))^{(N-1)})A \begin{pmatrix} G(\lambda) \\ G'(\lambda) \\ \vdots \\ G^{(N-1)}(\lambda) \end{pmatrix} \Big|_{\lambda=0}$$

(2.11)

$$\begin{aligned}
 & + (\lambda^N r(\lambda)G(\lambda), (\lambda^N r(\lambda)G(\lambda))', \dots, (\lambda^N r(\lambda)G(\lambda))^{(N-1)})A \overline{\begin{pmatrix} G(\lambda) \\ G'(\lambda) \\ \vdots \\ G^{(N-1)}(\lambda) \end{pmatrix}} \Big|_{\lambda=0} \\
 & = c_0(G(\lambda), G'(\lambda), \dots, G^{(N-1)}(\lambda))A \overline{\begin{pmatrix} G(\lambda) \\ G'(\lambda) \\ \vdots \\ G^{(N-1)}(\lambda) \end{pmatrix}} \Big|_{\lambda=0}.
 \end{aligned}$$

Note that $c_0 = \rho(0) > 0$, see (2.2). Since A is a positive semi-definite Hermitian matrix, we obtain

$$(2.12) \quad \widehat{A} \geq 0.$$

The first term on the left hand side of (2.9) is also non-negative. Consequently, both terms on the left hand side of (2.9) are equal to zero. By virtue of (2.11) we get

$$(2.13) \quad (G(\lambda), G'(\lambda), \dots, G^{(N-1)}(\lambda))A \overline{\begin{pmatrix} G(\lambda) \\ G'(\lambda) \\ \vdots \\ G^{(N-1)}(\lambda) \end{pmatrix}} \Big|_{\lambda=0} = 0.$$

In the case $A = 0$, Equation (2.13) is trivial.

If the interval $[a, b]$ is finite, then, since $\rho(x)$ is continuous on $[a, b]$, there exists a point $x_m \in [a, b]$ such that

$$(2.14) \quad \rho(x) \geq \rho(x_m) > 0, \quad x \in [a, b].$$

If $a = -\infty$ and/or $b = \infty$, we observe that $|\rho(x)| \rightarrow +\infty$, as $x \rightarrow \infty$. So we can say that in any case

$$(2.15) \quad \rho(x) \geq m_0 > 0, \quad x \in [a, b],$$

holds. Consequently, we can write

$$\begin{aligned}
 0 & = \int_{L_N} \rho(\lambda^N)(G(\lambda), G(\lambda\varepsilon), G(\lambda\varepsilon^2), \dots, G(\lambda\varepsilon^{N-1}))dM(\lambda) \overline{\begin{pmatrix} G(\lambda) \\ G(\lambda\varepsilon) \\ \vdots \\ G(\lambda\varepsilon^{N-1}) \end{pmatrix}} \\
 & \geq m_0 \int_{L_N} (G(\lambda), G(\lambda\varepsilon), G(\lambda\varepsilon^2), \dots, G(\lambda\varepsilon^{N-1}))dM(\lambda) \overline{\begin{pmatrix} G(\lambda) \\ G(\lambda\varepsilon) \\ \vdots \\ G(\lambda\varepsilon^{N-1}) \end{pmatrix}}.
 \end{aligned}$$

Therefore

$$(2.16) \quad \int_{L_N} (G(\lambda), G(\lambda\varepsilon), G(\lambda\varepsilon^2), \dots, G(\lambda\varepsilon^{N-1}))dM(\lambda) \overline{\begin{pmatrix} G(\lambda) \\ G(\lambda\varepsilon) \\ \vdots \\ G(\lambda\varepsilon^{N-1}) \end{pmatrix}} = 0.$$

From relations (2.13),(2.16) it follows that $\sigma(G(\lambda), G(\lambda)) = 0$. Since $G \neq 0$, we obtain a contradiction with relation (1.19). This completes the proof. \square

As a corollary of Lemma 2.7 we get that the polynomial D_n , $n \in \mathbb{Z}_+$, has degree $n + Nl$. Moreover, the numbers $x_{j,k}$, $j = 1, 2, \dots, l$; $k = 1, 2, \dots, N$, are zeros of this polynomial. Hence, we have

$$(2.17) \quad D_n = \rho(\lambda^N)r_n(\lambda),$$

where $r_n(\lambda) \in \mathbb{P}$ with $\deg r_n = n$. Using the definition of D_n we can write

$$(2.18) \quad D_n = \sum_{j=n}^{n+Nl} \xi_j p_j(\lambda), \quad \xi_j \in \mathbb{C}, \xi_{n+Nl} \neq 0.$$

Using relations (2.18),(1.20) we write

$$(2.19) \quad 0 = \sigma \left(\sum_{j=n}^{n+Nl} \xi_j p_j(\lambda), t(\lambda) \right) = \sigma(D_n, t) = \sigma(\rho(\lambda^N)r_n(\lambda), t(\lambda)) = \sigma_\rho(r_n(\lambda), t(\lambda)),$$

for an arbitrary $t(\lambda) \in \mathbb{P} : \deg t \leq n - 1$. Here we set

$$(2.20) \quad \begin{aligned} \sigma_\rho(u, v) &:= \sigma(\rho(\lambda^N)u, v) \\ &= \int_{\{z \in \mathbb{C} : z^N \in [a, b]\}} (u(\lambda), u(\lambda\varepsilon), u(\lambda\varepsilon^2), \dots, u(\lambda\varepsilon^{N-1}))\rho(\lambda^N)dM(\lambda) \overline{\begin{pmatrix} v(\lambda) \\ v(\lambda\varepsilon) \\ \vdots \\ v(\lambda\varepsilon^{N-1}) \end{pmatrix}} \\ &+ \rho(0)(u(0), u'(0), u''(0), \dots, u^{(N-1)}(0))A \overline{\begin{pmatrix} v(0) \\ v'(0) \\ \vdots \\ v^{(N-1)}(0) \end{pmatrix}}, \quad u, v \in \mathbb{P}. \end{aligned}$$

The functional σ_ρ is bilinear. It satisfies relations (1.16), (1.17) and (1.18). It is straightforward to see that (1.19) holds for the functional σ_ρ . From relations (2.19) and (1.17) (for σ_ρ) we obtain

$$(2.21) \quad \sigma_\rho(r_n(\lambda), r_m(\lambda)) = 0, \quad n, m \in \mathbb{Z}_+, n \neq m.$$

Polynomials $\{r_n\}_{n \in \mathbb{Z}_+}$, $\deg r_n = n$, which satisfy the relation (2.21), are said to be *orthogonal with respect to σ_ρ* .

Let $\{t_n(\lambda)\}_{n=0}^\infty$ (t_n has degree n and a positive leading coefficient) be orthonormal polynomials corresponding to the positive measure $\rho(\lambda)dM(\lambda)$ and the matrix $\rho(0)A$, which are constructed as in the introduction. We have

$$(2.22) \quad \sigma_\rho(t_n(\lambda), t_m(\lambda)) = \delta_{n,m}, \quad n, m \in \mathbb{Z}_+.$$

We will call such polynomials $\{t_n(\lambda)\}_{n=0}^\infty$ *orthonormal with respect to σ_ρ* . If $t_n(\lambda) = \mu_n \lambda^n + \dots$; $r_n(\lambda) = \widehat{\mu}_n \lambda^n + \dots$, then $\sigma_\rho \left(r_n - \frac{\widehat{\mu}_n}{\mu_n} t_n, r_n - \frac{\widehat{\mu}_n}{\mu_n} t_n \right) = 0$. By (1.19) we get $r_n = \frac{\widehat{\mu}_n}{\mu_n} t_n$, $n \in \mathbb{Z}_+$. Thus, as in the case of orthogonal polynomials on \mathbb{R} , the orthogonal polynomials $\{r_n\}_{n \in \mathbb{Z}_+}$ differ by a constant factor from the orthonormal polynomials $\{t_n\}_{n \in \mathbb{Z}_+}$.

In the case when $\rho(x)$ has multiple zeros, one should replace the corresponding rows in the determinants (2.5) and (2.6) by rows with derivatives of order $0, 1, \dots, m - 1$ at such points, where m is the corresponding multiplicity. In this case our last considerations can be applied to obtain orthogonal polynomials $\{r_n\}_{n \in \mathbb{Z}_+}$, $\deg r_n = n$.

We summarize our results in the following theorem.

THEOREM (2.23). *Let $A \in \mathbb{C}_{N \times N}^\geq$ and $M(\lambda)$ be a $\mathbb{C}_{N \times N}$ -valued function on $L_N \setminus \{0\}$ which is non-decreasing on each ray $L_{N,k} \setminus \{0\}$, $k = 0, 1, \dots, 2N - 1$, in the direction from 0 to ∞ . Suppose that the function $M(\lambda)$ has all finite moments (1.14). Define the functional $\sigma(u, v)$, $u, v \in \mathbb{P}$, as in (1.15) and suppose that it satisfies relation (1.19). Let $\{p_n(\lambda)\}_{n=0}^\infty$ (p_n has degree n and a positive leading coefficient) be the corresponding sequence of orthonormal polynomials (1.20).*

Choose an interval $[a, b]$, $-\infty \leq a < b \leq +\infty$, such that relation (2.1) holds. Let $\rho(x) \in \mathbb{P}$, $\deg \rho = l$, $l \in \mathbb{N}$, be positive on $[a, b]$ and let it be given as in (1.4) with $c, x_j \in \mathbb{R}$, $c \neq 0$. If A is not the zero matrix, we assume that $\rho(0) > 0$.

Define polynomials D_n , $n \in \mathbb{Z}_+$, according to (2.5). For a multiple zero of $\rho(\lambda^N)$ of order m we replace the corresponding row in the determinant (2.5) by rows with the derivatives of order $0, 1, \dots, m - 1$ at this point.

Set $r_n(\lambda) := \frac{D_n(\lambda)}{\rho(\lambda^N)}$, $n \in \mathbb{Z}_+$. Define a functional $\sigma_\rho(u, v)$, $u, v \in \mathbb{P}$, as in (2.20).

Then the polynomials $\{r_n\}_{n \in \mathbb{Z}_+}$ are orthogonal with respect to σ_ρ .

Example. Let $N = 2$ and $M(\lambda)$ be a matrix function on $(\mathbb{R} \cup i\mathbb{R}) \setminus \{0\}$:

$$M(\lambda) = \begin{pmatrix} m(\lambda) & 0 \\ 0 & 0 \end{pmatrix},$$

where

$$m(\lambda) = \begin{cases} \lambda, & \lambda \in (0, 1] \\ -\lambda, & \lambda \in (0, -1] \\ -i\lambda, & \lambda \in (0, i] \\ i\lambda, & \lambda \in (0, -i] \\ 0, & \text{elsewhere,} \end{cases}$$

and $A = 0$. The function $M(\lambda)$ is non-decreasing on each radial ray of $(\mathbb{R} \cup i\mathbb{R}) \setminus \{0\}$ (see the paragraph after (1.13)).

Let $\{p_n(\lambda)\}_{n \in \mathbb{Z}_+}$ be the corresponding orthonormal polynomials (1.20) and $\sigma(u, v)$, $u, v \in \mathbb{P}$, be the corresponding bilinear functional (1.15).

Let $\{\tilde{p}_n(\lambda)\}_{n \in \mathbb{Z}_+}$, $\deg \tilde{p}_n = n$, be monic polynomials ($\tilde{p}_n(\lambda) = \lambda^n + \dots$) such that

$$(2.24) \quad \sigma(\tilde{p}_n(\lambda), \tilde{p}_m(\lambda)) = \int_{-1}^1 \tilde{p}_n(\lambda) \overline{\tilde{p}_m(\lambda)} d\lambda + \int_{-i}^i \tilde{p}_n(\lambda) \overline{\tilde{p}_m(\lambda)} \frac{d\lambda}{i} = A_n \delta_{n,m},$$

where $A_n > 0, n, m \in \mathbb{Z}_+$. Such polynomials were studied by Milovanović in [11]. If we apply Lemma 6.2 and Theorem 6.5 in [11], we obtain

$$(2.25) \quad \tilde{P}_{4k+\nu}(z) = z^\nu q_k^{(\nu)}(z^4), \quad \nu = 0, 1, 2, 3, \quad k \in \mathbb{Z}_+,$$

and the polynomials $q_k^{(\nu)}(x)$ are monic orthogonal polynomials on $[0, 1]$ with respect to the weight $x^{\frac{2\nu-3}{4}}$.

Let $\{\tilde{P}_n^{(\alpha,\beta)}(x)\}_{n \in \mathbb{Z}_+}$ be the monic Jacobi polynomials. The Jacobi polynomials are orthogonal in the interval $[-1, 1]$ with respect to the weight function $(1-x)^\alpha(1+x)^\beta$ for $\alpha, \beta > -1$. The standard Rodrigues formula for Jacobi monic polynomials has the following form ([12, p. 271]):

$$(2.26) \quad \tilde{P}_n^{(\alpha,\beta)}(x) = \frac{(-1)^n \Gamma(\alpha + \beta + n + 1)}{\Gamma(\alpha + \beta + 2n + 1) \Gamma(\alpha + 1) \Gamma(\beta + 1)} [(1-x)^{\alpha+n}(1+x)^{\beta+n}]^{(n)}, \quad n \in \mathbb{Z}_+.$$

Here $\Gamma(a) = \int_0^\infty t^{a-1} e^{-t} dt, a > 0$, is the Euler’s gamma function.

Using a change of variable, we see that the polynomials $\{\frac{1}{2^n} \tilde{P}_n^{(\alpha,\beta)}(2x-1)\}_{n \in \mathbb{Z}_+}$ are monic orthogonal polynomials on $[0, 1]$ with respect to $(1-x)^\alpha x^\beta$. Hence, we get

$$(2.27) \quad q_n^{(\nu)}(x) = \frac{1}{2^n} \tilde{P}_n^{(0, \frac{2\nu-3}{4})}(2x-1), \quad \nu = 0, 1, 2, 3, \quad n \in \mathbb{Z}_+.$$

Thus we obtain

$$(2.28) \quad \tilde{P}_{4k+\nu}(z) = \frac{1}{2^k} z^\nu \tilde{P}_k^{(0, \frac{2\nu-3}{4})}(2z^4-1), \quad \nu = 0, 1, 2, 3, \quad k \in \mathbb{Z}_+.$$

Denote

$$\|p\| := \sqrt{\sigma(p, p)}, \quad p \in \mathbb{P}.$$

Note that

$$(2.29) \quad p_n(\lambda) = \frac{\tilde{p}_n}{\|\tilde{p}_n\|}, \quad n \in \mathbb{Z}_+.$$

In fact, orthonormal polynomials with positive leading coefficients are unique (see the reasoning about polynomials r_n and t_n above).

In [11, p. 132] it was shown that

$$(2.30) \quad \|\tilde{p}_n\|^2 = \frac{4}{2n+1}, \quad n = 0, 1, 2, 3;$$

$$(2.31) \quad \|\tilde{p}_n\|^2 = \|\tilde{p}_{4k+\nu}\|^2 = \frac{4}{8n+2\nu+1} \left(\prod_{k=n}^{2n-1} \frac{4(k-n+1)}{4k+2\nu+1} \right)^2, \quad n \geq 4.$$

So, we have explicit formulas for the polynomials $p_n(\lambda)$.

Now we shall derive explicit formulas for a new system of orthogonal polynomials. In order to use Theorem 2.23 we take $[a, b] = [-1, 1]$. Choose $\rho(x) = x + c, c > 1$. The polynomial $\rho(x)$ is positive on $[-1, 1]$ and $\rho(\lambda^2) = \lambda^2 + c = (\lambda + i\sqrt{c})(\lambda - i\sqrt{c})$. Hence, the determinants D_n in (2.5) will take the following form:

$$(2.32) \quad D_n = \begin{vmatrix} p_n(\lambda) & p_{n+1}(\lambda) & p_{n+2}(\lambda) \\ p_n(i\sqrt{c}) & p_{n+1}(i\sqrt{c}) & p_{n+2}(i\sqrt{c}) \\ p_n(-i\sqrt{c}) & p_{n+1}(-i\sqrt{c}) & p_{n+2}(-i\sqrt{c}) \end{vmatrix}, \quad n \in \mathbb{Z}_+.$$

Consequently, the orthogonal polynomials $\{r_n(\lambda)\}_{n \in \mathbb{Z}_+}$ corresponding to $M_1(\lambda)$ such that $dM_1(\lambda) = (\lambda^2 + c)dM(\lambda)$ have the following form

$$(2.33) \quad r_n(\lambda) = \frac{1}{\lambda^2 + c} \begin{vmatrix} p_n(\lambda) & p_{n+1}(\lambda) & p_{n+2}(\lambda) \\ p_n(i\sqrt{c}) & p_{n+1}(i\sqrt{c}) & p_{n+2}(i\sqrt{c}) \\ p_n(-i\sqrt{c}) & p_{n+1}(-i\sqrt{c}) & p_{n+2}(-i\sqrt{c}) \end{vmatrix}, \quad n \in \mathbb{Z}_+.$$

3. Some generalizations of kernel polynomials

In this section we generalize the results on kernel polynomials mentioned in the introduction. Let $M(\lambda)$ and A be as explained in the introduction and let $\{p_n(\lambda)\}_{n=0}^\infty$ (p_n has degree n and a positive leading coefficient) be a sequence of orthonormal polynomials which satisfies (1.20). Let σ be the bilinear functional (1.15). Set

$$(3.1) \quad \tilde{K}_n(x, y) = \sum_{j=0}^n p_j(x)\overline{p_j(y)}, \quad n \in \mathbb{Z}_+.$$

These polynomials were studied in [5] where in particular, some asymptotic formulas were obtained.

The orthogonality relations imply immediately the following reproducing property:

$$(3.2) \quad \sigma_t(P(t), \tilde{K}_n(t, \lambda)) = P(\lambda), \quad P \in \mathbb{P} : \deg P \leq n.$$

Here σ_t means that σ acts on polynomials in the variable t .

THEOREM (3.3). *Let λ_0 be an arbitrary complex value and let $P(\lambda) \in \mathbb{P}$ be such that*

$$(3.4) \quad \sigma(P, P) = 1.$$

The maximum value of $\|P(\lambda_0)\|^2$ is attained for polynomials

$$(3.5) \quad P(\lambda) = \varepsilon \{\tilde{K}_n(\lambda_0, \lambda_0)\}^{-\frac{1}{2}} \tilde{K}_n(\lambda, \lambda_0), \quad |\varepsilon| = 1.$$

The maximum value is $\tilde{K}_n(\lambda_0, \lambda_0)$.

To prove the theorem one needs only to repeat the arguments from the classical proof.

Polynomials $\{q_n(\lambda)\}_{n=0}^\infty$, $\deg q_n = n$, are said to be N -orthogonal with respect to the functional σ if

$$(3.6) \quad \sigma(q_n, q_m) = 0, \quad n, m \in \mathbb{Z}_+ : |n - m| \geq N.$$

Note that in the case $N = 2$, we obtain the quasi-orthogonal polynomials (q_n is a quasi-orthogonal polynomial of order n , see [3, Chapter II.5]).

THEOREM (3.7). *Suppose that relation (2.1) is true for a finite $[a, b] \subset \mathbb{R}$. Let $x_0 > \max(|a|, |b|)$. Then the polynomials $\{\tilde{K}_n(\lambda, \sqrt[N]{x_0})\}_{n \in \mathbb{Z}_+}$ are N -orthogonal with respect to the functional $\hat{\sigma}$ defined by $(x_0 - \lambda^N)dM(\lambda)$ instead of $dM(\lambda)$, and the matrix A .*

Proof. By inserting $P(t) = (x_0 - t^N)P_{n-N}(t)$, $\deg P_{n-N} \leq n - N$, and $\lambda = \sqrt[n]{x_0} > 0$ in (3.2), we obtain

$$(3.8) \quad 0 = \sigma_t((x_0 - t^N)P_{n-N}(t), \widetilde{K}_n(t, \sqrt[n]{x_0})) = \widehat{\sigma}_t(P_{n-N}(t), \widetilde{K}_n(t, \sqrt[n]{x_0})),$$

where $\widehat{\sigma}$ corresponds to the matrix function $(x_0 - \lambda^N)M(\lambda)$. From the latter relation it follows that polynomials $\widetilde{K}_n(t, \sqrt[n]{x_0})$ are N-orthogonal. \square

The following proposition also shows that N-orthogonal polynomials are some generalizations of quasi-orthogonal polynomials (see [1]).

PROPOSITION (3.9). *Let polynomials $\{\widetilde{q}_n(\lambda)\}_{n=0}^\infty$, $\deg \widetilde{q}_n = n$, be given. They are N-orthogonal with respect to the functional σ if and only if they have the following form*

$$(3.10) \quad \widetilde{q}_n(\lambda) = \sum_{j=n-N+1}^n a_{n,j} p_j(\lambda), \quad a_{n,j} \in \mathbb{C}, \quad a_{n,n} \neq 0, \quad n \in \mathbb{Z}_+.$$

By convention, polynomials with negative indices will be zero.

The proof is straightforward using the orthogonality of $\{p_n(x)\}_{n=0}^\infty$.

4. Relations between the recursion coefficients

We shall establish some relations between the recursion coefficients of the original polynomials $\{p_n(\lambda)\}_{n=0}^\infty$ in Theorem 2.23 and the recursion coefficients of the polynomials $\{r_n(\lambda)\}_{n=0}^\infty$ corresponding to the perturbed measure.

First we obtain relations between the coefficients of the polynomials $\{p_n(\lambda)\}_{n=0}^\infty$ satisfying (1.21) and their recursion coefficients. Assume that the polynomial $p_k(\lambda)$ has the following form:

$$(4.1) \quad p_k(\lambda) = \sum_{j=0}^k \mu_{k,j} \lambda^j, \quad \mu_{k,j} \in \mathbb{C}, \quad \mu_{k,k} > 0, \quad k \in \mathbb{Z}_+.$$

Comparing the coefficients of the term λ^{k+N-b} , $0 \leq b \leq N$, on the both sides of the recurrence relation (1.21) gives

$$(4.2) \quad \sum_{j=N-b}^N \alpha_{k,j} \mu_{k+j,k+N-b} = \mu_{k,k-b},$$

where, by convention, $\mu_{i,j}$ with negative indices are zero. From the latter relation we get

$$(4.3) \quad \alpha_{k,N} = \frac{\mu_{k,k}}{\mu_{k+N,k+N}},$$

$$\alpha_{k,N-b} = \frac{1}{\mu_{k+N-b,k+N-b}} \left(\mu_{k,k-b} - \sum_{j=N-b+1}^N \alpha_{k,j} \mu_{k+j,k+N-b} \right), \quad b = 1, 2, \dots, N.$$

On the other hand, from relation (4.2) it follows that

$$(4.4) \quad \mu_{k+N,k+N} = \frac{1}{\alpha_{k,N}} \mu_{k,k};$$

$$(4.5) \quad \mu_{k+N,k+N-b} = \frac{1}{\alpha_{k,N}} \left(\mu_{k,k-b} - \sum_{j=N-b}^{N-1} \alpha_{k,j} \mu_{k+j,k+N-b} \right), \quad b = 1, 2, \dots, N.$$

We set

$$c_{i,j} := \mu_{i,j}, \quad i = 0, \dots, N - 1; \quad 0 \leq j \leq i.$$

From (4.4),(4.5) one can define coefficients $\mu_{k,j}$, $k, j \in \mathbb{Z}_+$ with $k - N \leq j \leq k$, depending only on the coefficients $\alpha_{k,j}$ and the constants $c_{i,j}$, $i = 0, \dots, N - 1$; $0 \leq j \leq i$. These are not all coefficients $\mu_{k,j}$, but that is enough for our further purposes.

We introduce some additional notation. Set

$$A_j = (p_j(x_{1,1}), p_j(x_{1,2}), \dots, p_j(x_{1,N}), \dots, p_j(x_{l,1}), p_j(x_{l,2}), \dots, p_j(x_{l,N}))^T, \quad j \in \mathbb{Z}_+,$$

where the superscript T means the transpose of a matrix. We also set

$$d_{n,j} = \det D_{n,j}, \quad n \in \mathbb{Z}_+, \quad 0 \leq j \leq Nl,$$

where $D_{n,j}$ is obtained from the rectangular matrix

$$(A_n, A_{n+1}, \dots, A_{n+Nl})$$

by removing the column A_{n+j} . Note that

$$(4.6) \quad d_{n,Nl} = d_n, \quad d_{n,0} = d_{n+1},$$

where d_n are given in (2.6).

For the polynomials $\{r_n(\lambda)\}_{n=0}^\infty$, relation (1.21) reads

$$(4.7) \quad \sum_{j=1}^N (\widehat{\alpha}_{k-j,j} r_{k-j}(\lambda) + \widehat{\alpha}_{k,j} r_{k+j}(\lambda)) + \widehat{\alpha}_{k,0} r_k(\lambda) = \lambda^N r_k(\lambda), \quad k \in \mathbb{Z}_+,$$

where $\widehat{\alpha}_{m,n} \in \mathbb{C}$, $m, n \in \mathbb{Z}_+$ with $\widehat{\alpha}_{m,N} > 0, \widehat{\alpha}_{m,0} \in \mathbb{R}$, and all $\widehat{\alpha}_{m,n}, r_k$ with negative indices are equal to zero. Using the definition of the polynomials $r_n(\lambda)$ we get

$$\sum_{j=1}^N (\widehat{\alpha}_{k-j,j} D_{k-j}(\lambda) + \widehat{\alpha}_{k,j} D_{k+j}(\lambda)) + \widehat{\alpha}_{k,0} D_k(\lambda) = \lambda^N D_k(\lambda), \quad k \in \mathbb{Z}_+.$$

From the definition of the polynomials $D_n(\lambda)$ it follows that

$$(4.8) \quad \sum_{j=1}^N \widehat{\alpha}_{k-j,j} \begin{vmatrix} p_{k-j}(\lambda) & p_{k-j+1}(\lambda) & \dots & p_{k-j+Nl}(\lambda) \\ A_{k-j} & A_{k-j+1} & \dots & A_{k-j+Nl} \end{vmatrix} \\ + \sum_{j=0}^N \widehat{\alpha}_{k,j} \begin{vmatrix} p_{k+j}(\lambda) & p_{k+j+1}(\lambda) & \dots & p_{k+j+Nl}(\lambda) \\ A_{k+j} & A_{k+j+1} & \dots & A_{k+j+Nl} \end{vmatrix} \\ = \lambda^N \begin{vmatrix} p_k(\lambda) & p_{k+1}(\lambda) & \dots & p_{k+Nl}(\lambda) \\ A_k & A_{k+1} & \dots & A_{k+Nl} \end{vmatrix}, \quad k \in \mathbb{Z}_+.$$

We shall compare the coefficients of the $\lambda^{k+Nl+N-s}$, $0 \leq s \leq N$, on both sides of the relation (4.8). Note that the first sum on the left hand side of (4.8) has no such terms. In the second sum, summands with j such that $k + j + Nl < k + Nl + N - s$, have also no such terms. So, it is sufficient to consider summands with j such that $N - s \leq j \leq N$.

Consider the summand with the index $j = N - s + v$, $0 \leq v \leq s$:

$$\begin{aligned}
 \widehat{\alpha}_{k,N-s+v} & \left| \begin{array}{cccc} p_{k+N-s+v}(\lambda) & p_{k+N-s+v+1}(\lambda) & \cdots & p_{k+N-s+v+Nl}(\lambda) \\ A_{k+N-s+v} & A_{k+N-s+v+1} & \cdots & A_{k+N-s+v+Nl} \end{array} \right| = \\
 (4.9) \quad & = \widehat{\alpha}_{k,N-s+v} \sum_{c=0}^{Nl} (-1)^c p_{k+N-s+v+c}(\lambda) d_{k+N-s+v,c}.
 \end{aligned}$$

Note that if $k + N - s + v + c < k + Nl + N - s$, then the summand of the last sum with the index c has no required terms. Therefore it is enough to consider summands with $c \geq Nl - v$:

$$(4.10) \quad \widehat{\alpha}_{k,N-s+v} \sum_{c=Nl-v}^{Nl} (-1)^c p_{k+N-s+v+c}(\lambda) d_{k+N-s+v,c}.$$

Thus, the coefficient by $\lambda^{k+Nl+N-s}$ in the summand with the index $j = N - s + v$ is

$$(4.11) \quad \widehat{\alpha}_{k,N-s+v} \sum_{c=Nl-v}^{Nl} (-1)^c \mu_{k+N-s+v+c,k+Nl+N-s} d_{k+N-s+v,c}.$$

Consequently, the coefficient by $\lambda^{k+Nl+N-s}$ on the left hand side of the relation (4.8) is

$$(4.12) \quad L := \sum_{v=0}^s \widehat{\alpha}_{k,N-s+v} \sum_{c=Nl-v}^{Nl} (-1)^c \mu_{k+N-s+v+c,k+Nl+N-s} d_{k+N-s+v,c}.$$

The right-hand side of the (4.8) is equal to

$$(4.13) \quad \lambda^N \sum_{c=0}^{Nl} (-1)^c p_{k+c}(\lambda) d_{k,c}.$$

For indices c such that $N + k + c < k + Nl + N - s$, the summands of the last sum have no terms with $\lambda^{k+Nl+N-s}$. So, it is sufficient to consider the sum

$$(4.14) \quad \lambda^N \sum_{c=Nl-s}^{Nl} (-1)^c p_{k+c}(\lambda) d_{k,c}.$$

Thus, the coefficient by $\lambda^{k+Nl+N-s}$ on the right-hand side of the relation (4.8) is

$$(4.15) \quad R := \sum_{c=Nl-s}^{Nl} (-1)^c \mu_{k+c,k+Nl-s} d_{k,c},$$

where all $\mu_{i,j}$ with negative indices are equal to zero. Comparing relations (4.12) and (4.15) we obtain

$$\begin{aligned}
 (4.16) \quad & \sum_{v=0}^s \widehat{\alpha}_{k,N-s+v} \sum_{c=Nl-v}^{Nl} (-1)^c \mu_{k+N-s+v+c,k+Nl+N-s} d_{k+N-s+v,c} \\
 & = \sum_{c=Nl-s}^{Nl} (-1)^c \mu_{k+c,k+Nl-s} d_{k,c}, \quad 0 \leq s \leq N.
 \end{aligned}$$

From this equality, we get the following theorem.

THEOREM (4.17). *Let $\{p_n(\lambda)\}_{n=0}^\infty$ and $\{r_n(\lambda)\}_{n=0}^\infty$ be the sequences of orthonormal polynomials defined as in Theorem 2.23. The coefficients of the recurrence relation (4.7) for the polynomials $r_n(\lambda)$ can be deduced from the following relations:*

$$(4.18) \quad \hat{\alpha}_{k,N} = \frac{\mu_{k+NI,k+NI}d_k}{\mu_{k+NI+N,k+NI+N}d_{k+N}} = \alpha_{k+NI,N} \frac{d_k}{d_{k+N}},$$

$$(4.19) \quad \hat{\alpha}_{k,N-s} = \frac{(-1)^{NI}}{\mu_{N(l+1)+k-s,N(l+1)+k-s}d_{k+N-s}} \left(\sum_{c=NI-s}^{NI} (-1)^c \mu_{k+c,k+NI-s}d_{k,c} - \sum_{v=1}^s \hat{\alpha}_{k,N-s+v} \sum_{c=NI-v}^{NI} (-1)^c \mu_{k+N-s+v+c,k+NI+N-s}d_{k+N-s+v,c} \right), \quad 1 \leq s \leq N.$$

The coefficients $\mu_{i,j}$ in relation (4.19) can be obtained from (4.4) and (4.5).

Acknowledgments

The authors thank the referees for their valuable comments and suggestions. The authors are especially grateful to the referee who suggested the study of relations between the original and the perturbed polynomials in the generalized Christoffel formula (2.5).

Received August 1, 2008

Final version received May 13, 2009

ABDON EDDY CHOQUE RIVERO
 INSTITUTO DE FÍSICA Y MATEMÁTICAS,
 UNIVERSIDAD MICHOACANA DE
 SAN NICOLÁS DE HIDALGO,
 CIUDAD UNIVERSITARIA,
 MORELIA, MICH.,
 C.P. 58048, MÉXICO
 abdon@ifm.umich.mx

SERGEY M. ZAGORODNYUK
 SCHOOL OF MATHEMATICS AND MECHANICS
 KARAZIN KHARKIV NATIONAL UNIVERSITY
 KHARKIV, 61077
 UKRAINE
 Sergey.M.Zagorodnyuk@univer.kharkov.ua

REFERENCES

- [1] N. I. AKHIEZER, The classical moment problem. Oliver and Boyd, Edinburgh, 1965.
- [2] C. BREZINSKI, *A direct proof of the Christoffel-Darboux identity and its equivalence to the recurrence relationship*, *Comput. Appl. Math.*, **32** (1990), 17–25.
- [3] T. S. CHIHARA, *An introduction to orthogonal polynomials*. Gordon and Breach, Science Publishers, New York, London, Paris, 1978.

- [4] A. J. DURAN, *A generalization of Favard's theorem for polynomials satisfying a recurrence relation*, J. Approx. Theory, **74** (1993), 83–109.
- [5] A. J. DURAN, *On orthogonal polynomials with respect to a positive definite matrix of measures*, Canad. J. Math., **47** (1995) 88–112.
- [6] A. J. DURAN, E. B. SAFF, *Zero location for nonstandard orthogonal polynomials*, J. Approx. Theory **113** (2001) 127–141.
- [7] A. J. DURAN, W. VAN ASSCHE, *Orthogonal matrix polynomials and higher order recurrence relations*, Linear Algebra and Appl., **219** (1995) 261–280.
- [8] W. GAUTSCHI, *An algorithmic implementation of the generalized Christoffel Theorem*, in Numerical Integration, G. Hämmerlin Editor, ISNM **57**, Birkhäuser Verlag, Basel, 1982, 89–106.
- [9] S. KARLIN, J. MCGREGOR, *Some properties of determinants of orthogonal polynomials*, in Theory and Applications of Special Functions, R. A. Askey Editor, Academic Press, New York, 1975, 521–550.
- [10] F. MARCELLÁN, S. M. ZAGORODNYUK, *On the basic set of solutions of a high-order linear difference equation*, J. Difference Equ. Appl., **12**, No. 2 (2006), 213–228.
- [11] G. V. MILOVANOVIĆ, *A class of orthogonal polynomials on the radial rays in the complex plane*, J. Math. Anal. Appl., **206** (1997), 121–139.
- [12] P. K. SUETIN, *Classical orthogonal polynomials*. Nauka, Moscow, 1979. (Russian)
- [13] G. SZEGÖ, *Orthogonal polynomials*. Amer. Math. Soc. Coll. Publ. **23**. Amer. Math. Soc. Providence RI (1975). Fourth Edition.
- [14] S. M. ZAGORODNYUK, *Orthogonal polynomials on the real and the imaginary axes in the complex plane*, Matem. Fizika, Analiz, Geometr., **9**, No. 3 (2002), 502-508. (Russian)
- [15] S. M. ZAGORODNYUK, *On generalized Jacobi matrices and orthogonal polynomials*, New York J. Math., **9** (2003), 117–136.
- [16] S. M. ZAGORODNYUK, *Orthogonal polynomials on rays: properties of zeros, related moment problems and symmetries*, Zh. Mat. Fiz. Anal. Geom., **4**, No. 3 (2008), 395-419.

ROTUNDITY AND CONNECTEDNESS IN TWO DIMENSIONS

FRANCISCO JAVIER GARCÍA-PACHECO

ABSTRACT. The main result in this paper assures that if X is a 2-dimensional real Banach space then X is rotund if and only if every closed, connected subset of S_X is of the form $B_X(x, r) \cap S_X$.

1. Introduction

Rotund spaces are exactly those Banach spaces whose unit sphere does not contain non-trivial segments. It is well known and actually easy to check that rotundity is a 2-dimensional property, that is, a Banach space is rotund if and only if all of its 2-dimensional subspaces are rotund. Therefore, in order to characterize this property, it is sufficient to look at the 2-dimensional subspaces. In this paper, we present a topological characterization of rotundity in terms of connectedness in 2-dimensional real Banach spaces. Almost any book on geometry of Banach spaces is an appropriate reference for this property. In particular, we refer the reader to [JD] for a wide perspective on this topic.

It is convenient to explain the notation used in this paper even though it is rather usual. Let X denote a Banach space. We have that B_X , U_X , and S_X denote, respectively, the closed unit ball of X , the open unit ball of X , and the unit sphere of X . In the same manner, if x is a vector of X and r is a non-negative real number, then $B_X(x, r)$, $U_X(x, r)$, and $S_X(x, r)$ denote the closed unit ball of center x and radius r , the open unit ball of center x and radius r , and the unit sphere of center x and radius r , respectively. Also, if X denotes a topological space and A is a subset of X , then $\text{int}(A)$, $\text{bd}(A)$, and $\text{cl}(A)$ will denote, respectively, the interior of A , the boundary of A , and the closure of A . In the same way, if B is a subset of A , then $\text{int}_A(B)$, $\text{bd}_A(B)$, and $\text{cl}_A(B)$ will denote (respectively) the interior of B with respect to A , the boundary of B with respect to A , and the closure of B with respect to A .

2. Background

Along this manuscript we will rely upon some well known facts and theorems that we will state without proofs in this section.

FACT (2.1). *Let X be a 2-dimensional real Banach space. Then, the mapping*

$$\begin{aligned} S_X &\longrightarrow S_{\ell_2^2} \\ x &\longmapsto x / \|x\|_2 \end{aligned}$$

is a homeomorphism.

2000 *Mathematics Subject Classification*: Primary 46B04, 46B20.

Keywords and phrases: 2-dimensional real Banach space, rotundity, connectedness.

FACT (2.2). *Let X be a real Banach space. Then for every $x \in S_X$ we have that $S_X \setminus \{x\}$ is homeomorphic to a hyperplane of X .*

THEOREM (2.3). *Let X be a 2-dimensional real Banach space. Then:*

1. *For any $a \neq b \in S_X$, the set $S_X \setminus \{a, b\}$ has exactly two connected components.*
2. *For every closed, connected subset C of S_X such that $\text{diam}(C) > 0$ and $C \neq S_X$, there exist two different points $a, b \in S_X$ satisfying $\text{bd}_{S_X}(C) = \{a, b\}$. Furthermore, $C \setminus \{a, b\}$ and $S_X \setminus C$ are the two connected components of $S_X \setminus \{a, b\}$.*
3. *If C and D are two closed, connected subsets of S_X such that $\text{bd}_{S_X}(C) = \text{bd}_{S_X}(D)$ and $\text{int}_{S_X}(C) \cap \text{int}_{S_X}(D) \neq \emptyset$, then $C = D$.*
4. *If U and V are two open, connected subsets of S_X such that $\text{bd}_{S_X}(U) = \text{bd}_{S_X}(V)$ and $U \cap V \neq \emptyset$, then $U = V$.*

THEOREM (2.4). *Let X be a 2-dimensional real Banach space. Let $a \neq b \in S_X$. Then:*

1. *If $a = -b$, then $f^{-1}((0, +\infty)) \cap S_X$ and $f^{-1}((-\infty, 0)) \cap S_X$ are the two connected components of $S_X \setminus \{a, b\}$, where $f \in X^*$ is such that $f(a) = 0$. Note that each of these components is the opposite of the other.*
2. *If $a \neq -b$, then $f^{-1}((-\infty, 1)) \cap S_X$ and*

$$f^{-1}((1, +\infty)) \cap S_X = \left\{ \frac{ta + (1-t)b}{\|ta + (1-t)b\|} : t \in (0, 1) \right\}$$

are the two connected components of $S_X \setminus \{a, b\}$, where $f \in X^$ is the only functional such that $f(a) = f(b) = 1$. Note that the opposite of the second component is contained in the first one.*

3. Connectedness in the unit sphere

Our first aim is to study the connectedness of the sets $B_X(x, r) \cap S_X$, $U_X(x, r) \cap S_X$, and $S_X(x, r) \cap S_X$, where X is a 2-dimensional real Banach space, $x \in S_X$, and $r \geq 0$. In order to do that, we will need the following key lemma.

LEMMA (3.1). *Let X be a real Banach space. Let $x, y \in S_X$ such that $x \neq -y$. Then*

$$\left\| \frac{tx + (1-t)y}{\|tx + (1-t)y\|} - x \right\| \leq \|y - x\|$$

for every $t \in [0, 1]$. Moreover, if there exists $t \in (0, 1)$ such that

$$\left\| \frac{tx + (1-t)y}{\|tx + (1-t)y\|} - x \right\| = \|y - x\|,$$

then the segment $\left[y, \frac{tx + (1-t)y}{\|tx + (1-t)y\|} \right]$ lies on the unit sphere.

Proof. First, fix $t \in [0, 1]$ and note that

$$\begin{aligned} 1 - \|tx + (1-t)y\| &= \|y\| - \|tx + (1-t)y\| \\ &\leq \|y - (tx + (1-t)y)\| \\ &= t \|y - x\|. \end{aligned}$$

Let us denote $tx + (1 - t)y$ by z_t . We have that

$$\begin{aligned} \left\| \frac{z_t}{\|z_t\|} - x \right\| &= \frac{\|z_t - \|z_t\| x\|}{\|z_t\|} \\ &= \frac{\| \|z_t\| (1 - t)(y - x) + (1 - \|z_t\|) z_t \|}{\|z_t\|} \\ &\leq (1 - t) \|y - x\| + 1 - \|z_t\| \\ &\leq (1 - t) \|y - x\| + t \|y - x\| \\ &= \|y - x\|. \end{aligned}$$

Secondly, assume that $t \in (0, 1)$ is such that

$$\left\| \frac{tx + (1 - t)y}{\|tx + (1 - t)y\|} - x \right\| = \|y - x\|.$$

Then, $t \|y - x\| = 1 - \|tx + (1 - t)y\|$. Let us see that

$$\left\| \frac{1}{2}y + \frac{1}{2} \frac{tx + (1 - t)y}{\|tx + (1 - t)y\|} \right\| = 1.$$

Observe that it suffices to show that

$$\|(1 - t \|y - x\|) y + (tx + (1 - t)y)\| \geq 2(1 - t \|y - x\|),$$

which is clearly true, since

$$\begin{aligned} \|(1 - t \|y - x\|) y + (tx + (1 - t)y)\| &= \|t(x - y) + (2 - t \|y - x\|) y\| \\ &\geq (2 - t \|y - x\|) - t \|y - x\| \\ &= 2(1 - t \|y - x\|). \end{aligned}$$

□

With the help of the previous lemma we will prove the following two propositions.

PROPOSITION (3.2). *Let X be a real Banach space. Let $x \in S_X$ and $r \geq 0$. Then*

1. *If $r = 0$, then $B_X(x, r) \cap S_X = \{x\}$.*
2. *If $0 < r < 2$, then $B_X(x, r) \cap S_X$ is path-connected.*
3. *If $r \geq 2$, then $B_X(x, r) \cap S_X = S_X$.*

Proof. We spare the details of the proof of (1) and (3) to the reader. With respect to (2), bearing Lemma 3.1 in mind, the only aspect we have to take into account is that if $y \in B_X(x, r) \cap S_X$, then $y \neq -x$. □

PROPOSITION (3.3). *Let X be a real Banach space. Let $x \in S_X$ and $r \geq 0$. Then:*

1. *If $r = 0$, then $U_X(x, r) \cap S_X = \emptyset$.*
2. *If $0 < r \leq 2$, then $U_X(x, r) \cap S_X$ is path-connected.*
3. *If $r > 2$, then $U_X(x, r) \cap S_X = S_X$.*

Proof. Again, note that (1) and (3) do not require any proof. As to (2), we can make use of the same idea as in the proof of the previous proposition, that is, we keep in mind Lemma 3.1 and note that if $y \in U_X(x, r) \cap S_X$, then $y \neq -x$. □

The previous two propositions motivate the following questions.

Question (3.4). Let X be a 2-dimensional real Banach space. Then:

1. If C is a closed, connected subset of S_X , then do there exist $x \in S_X$ and $r \geq 0$ such that $C = B_X(x, r) \cap S_X$?
2. If U is an open, connected subset of S_X , then do there exist $x \in S_X$ and $r \geq 0$ such that $U = U_X(x, r) \cap S_X$?

The next example reveals that the answer to the previous questions is negative.

Example (3.5).

1. The closed, connected subset

$$C := \{(x, 1) \in \mathbb{R}^2 : 0 \leq x \leq 1\} \cup \{(1, y) \in \mathbb{R}^2 : -1 \leq y \leq 1\}$$

of $S_{\ell_\infty^2}$ is not of the form $B_{\ell_\infty^2}(x, r) \cap S_X$ for any $x \in S_{\ell_\infty^2}$ and $r \geq 0$.

2. The open, connected subset

$$U := \{(x, 1) \in \mathbb{R}^2 : 0 < x \leq 1\} \cup \{(1, y) \in \mathbb{R}^2 : -1 < y \leq 1\}$$

of $S_{\ell_\infty^2}$ is not of the form $U_{\ell_\infty^2}(x, r) \cap S_X$ for any $x \in S_{\ell_\infty^2}$ and $r \geq 0$.

Notice that ℓ_∞^2 is not rotund. Later on, we will see that in rotund 2-dimensional real Banach spaces, the connected subsets of the unit sphere are always given by intersection of balls with the unit sphere.

PROPOSITION (3.6). *Let X be a real Banach space. Let $x \in S_X$ and $r \geq 0$. Then:*

1. If $r = 0$, then $S_X(x, r) \cap S_X = \{x\}$.
2. If $0 < r < 2$, then
 - (a) if X has dimension 1, then $S_X(x, r) \cap S_X = \emptyset$;
 - (b) if X has dimension 2, then $S_X(x, r) \cap S_X$ has exactly two path-connected components which are segments;
 - (c) if X has dimension ≥ 3 , then $S_X(x, r) \cap S_X$ is path-connected.
3. If $r = 2$, then

$$S_X(x, r) \cap S_X = \bigcup \{f^{-1}(\{1\}) \cap B_X : f \in S_{X^*}, f(-x) = 1\}.$$

In case $S_X(x, r) \cap S_X$ is convex, there exists $f \in S_{X^*}$ such that $S_X(x, 2) \cap S_X = f^{-1}(\{1\}) \cap B_X$.

4. If $r > 2$, then $S_X(x, r) \cap S_X = \emptyset$.

Proof. Note once again that (1) and (4) do not require any proof. Let us prove (3). Take any $y \in S_X(x, r) \cap S_X$. Then

$$\left\| \frac{y + (-x)}{2} \right\| = 1.$$

By the Hahn-Banach Theorem, there exists $f \in S_{X^*}$ such that

$$f\left(\frac{y + (-x)}{2}\right) = 1.$$

It is clear that $f(y) = f(-x) = 1$. Now, take any $y \in f^{-1}(\{1\}) \cap B_X$ for some $f \in S_{X^*}$ with $f(-x) = 1$. Then

$$2 = f(y - x) \leq \|y - x\| \leq 2.$$

Suppose now that $S_X(x, r) \cap S_X$ is convex. By applying again the Hahn-Banach Theorem, we can find $f \in S_{X^*}$ such that $S_X(x, 2) \cap S_X \subseteq f^{-1}(\{1\}) \cap B_X$, and it is clear that $f(-x) = 1$. Finally, let us see (2). We spare the details of the proof of (a) to the reader.

- (b) First, to show that $S_X(x, r) \cap S_X$ has exactly two path-connected components, it is enough to recall that $B_X(x, r) \cap S_X$ as well as $U_X(x, r) \cap S_X$ are path-connected (Proposition 3.2 and Proposition 3.3) and that $S_X \setminus \{-x\}$ is homeomorphic to \mathbb{R} (Fact 2.2). Let us prove then that these two path-connected components are actually segments. Set $C := B_X(x, r) \cap S_X$. Since $0 < r < 2$, we have that $\text{diam}(C) > 0$ and $C \neq S_X$. Then, there are $a \neq b \in S_X$ such that $\{a, b\} = \text{bd}_{S_X}(C)$. Now, consider the continuous mapping $\phi : [0, 1] \rightarrow S_X$ defined for $t \in [0, 1/2]$ as

$$\phi(t) = \frac{(2t)x + (1 - 2t)a}{\|(2t)x + (1 - 2t)a\|}$$

and for $t \in [1/2, 1]$ as

$$\phi(t) = \frac{(2t - 1)b + (2 - 2t)x}{\|(2t - 1)b + (2 - 2t)x\|}.$$

Then, $D = \phi([0, 1])$ is a closed, connected subset of S_X satisfying $\text{bd}_{S_X}(D) = \text{bd}_{S_X}(C)$ and $\text{int}_{S_X}(D) \cap \text{int}_{S_X}(C) \supseteq \{x\} \neq \emptyset$. Thus, $D = C$ in virtue of Theorem 2.3. Since $U_X(x, r) \cap S_X \subseteq \text{int}_{S_X}(C)$, we have that $\text{bd}_{S_X}(C) \subseteq S_X(x, r) \cap S_X$. Let us denote by A the path-connected component of a in $S_X(x, r) \cap S_X$. We have that A is a closed, connected subset of S_X with $A \neq S_X$. If $\text{diam}(A) = 0$, then we are done. Assume that A has diameter strictly greater than 0. Let $a' \neq a$ such that $\text{bd}_{S_X}(A) = \{a, a'\}$. Clearly, the two connected components of $C \setminus \{x\}$ are $\phi([0, 1/2))$ and $\phi((1/2, 1])$, thus A must be contained in $\phi([0, 1/2))$. Now, by applying Lemma 3.1, the segment $[a', a]$ lies on the unit sphere and so $A = [a', a]$. Similarly, the other path-connected component of $S_X(x, r)$ is also a segment.

- (c) Similarly to the previous reasoning, to show that $S_X(x, r) \cap S_X$ is path-connected, we only need to take into consideration that $B_X(x, r) \cap S_X$ as well as $U_X(x, r) \cap S_X$ are path-connected and that $S_X \setminus \{-x\}$ is homeomorphic to a real Banach space of dimension ≥ 2 .

□

4. A characterization of rotundity for radii equal to 2

In the last two sections we will provide characterizations of rotundity involving connectedness in two real dimensions. The main idea is to make use of balls and spheres with radii strictly greater than 0 and less than or equal to 2. We will begin with the case of radii equal to 2.

PROPOSITION (4.1). *Let X be a real Banach space. Let $x \in S_X$. The following are equivalent:*

1. $\text{cl}_{S_X}(\cup_X(x, 2) \cap S_X) = S_X$.
2. $\text{bd}_{S_X}(\cup_X(x, 2) \cap S_X) = S_X(x, 2) \cap S_X$.
3. $\text{int}_{S_X}(S_X(x, 2) \cap S_X) = \emptyset$.

Proof. The proof is based upon the fact that $S_X(x, 2) \cap S_X$ is closed in S_X , $\cup_X(x, 2) \cap S_X$ is open in S_X , and

$$S_X = (\cup_X(x, 2) \cap S_X) \cup (S_X(x, 2) \cap S_X).$$

□

THEOREM (4.2). *Let X be a real Banach space. Then:*

1. X is rotund if and only if $S_X(x, 2) \cap S_X = \{-x\}$ for all $x \in S_X$. In particular, X satisfies all the equivalent conditions in the previous proposition for any $x \in S_X$.
2. If X is 2-dimensional, then X is rotund if and only if X satisfies all the equivalent conditions in the previous proposition for any $x \in S_X$.

Proof.

1. By applying Proposition 3.6, we observe that if X is rotund, then $S_X(x, 2) \cap S_X = \{-x\}$. On the other hand, if $[a, b]$ is a non-trivial segment contained in S_X , by Proposition 3.6 again, we have that $S_X(-\frac{a+b}{2}, 2) \cap S_X \supseteq [a, b]$.
2. Now, assume that X is 2-dimensional and satisfies all the equivalent conditions in the previous proposition. By hypothesis, we have that $S_X(x, 2) \cap S_X$ has empty interior relative to S_X for every $x \in S_X$, which necessarily means that $S_X(x, 2) \cap S_X = \{-x\}$ for every $x \in S_X$.

□

By taking into consideration Theorem 4.2, we can enunciate the following question.

Question (4.3). Let X be a 2-dimensional real Banach space such that $S_X(x, 2) \cap S_X$ is convex for every $x \in S_X$. Is then X rotund?

The next example reveals a negative answer to the previous question.

Example (4.4). The 2-dimensional real Banach space X such that

$$B_X := B_{\ell_2} \cap \left\{ (x, y) \in \mathbb{R}^2 : -\frac{1}{2} \leq y \leq \frac{1}{2} \right\}$$

verifies that $S_X(x, 2) \cap S_X$ is convex for every $x \in S_X$ but it is not rotund. Even more, the two path-connected components of $S_X((-1, 0), 1) \cap S_X$ are non-trivial segments, so X will not satisfy the equivalent conditions of the Proposition 5.1 and hence it will not be rotund in virtue of Theorem 5.2.

To finish this section, we present another characterization of rotundity.

THEOREM (4.5). *Let X be a real Banach space. The following conditions are equivalent:*

1. X is rotund.

2. If U is an open, connected subset of S_X with $\text{cl}_{S_X}(U) = S_X$, then there exists $x \in S_X$ such that $U = U_X(x, 2) \cap S_X$.

Proof. Assume first that X is rotund. Let U be an open, connected subset of S_X with $\text{cl}_{S_X}(U) = S_X$. Then, $S_X \setminus U = \{y\}$ for some $y \in S_X$. Now, $U_X(x, 2) \cap S_X$ and U are open, connected subsets of S_X whose interiors relative to S_X are non-empty. In accordance to Theorem 2.3, they must equal. Assume that (2) holds. Suppose on the contrary that X is not rotund. Let $[a, b]$ be a non-trivial segment contained in S_X . Set $U := S_X \setminus \{\frac{a+b}{2}\}$. By hypothesis, there exists $x \in S_X$ such that $U_X(x, 2) \cap S_X = U$. Then,

$$4 = \|2x - (a + b)\| \leq \|x - a\| + \|x - b\| \leq 4.$$

This necessarily means that $\|x - a\| = 2 = \|x - b\|$. However, this contradicts the fact that $a, b \in U_X(x, 2) \cap S_X$. □

5. A characterization of rotundity for radii strictly between 0 and 2

The version of Proposition 4.1 for radii strictly between 0 and 2 is expressed in the next proposition. This time, we will not have equivalent conditions to rotundity.

PROPOSITION (5.1). *Let X be a real Banach space. Let $x \in S_X$ and $0 < r < 2$. The following are equivalent:*

1. $\text{cl}_{S_X}(U_X(x, r) \cap S_X) = B_X(x, r) \cap S_X$.
2. $\text{int}_{S_X}(B_X(x, r) \cap S_X) = U_X(x, r) \cap S_X$.
3. $\text{bd}_{S_X}(B_X(x, r) \cap S_X) = S_X(x, r) \cap S_X$.
4. $\text{bd}_{S_X}(U_X(x, r) \cap S_X) = S_X(x, r) \cap S_X$.
5. $\text{int}_{S_X}(S_X(x, r) \cap S_X) = \emptyset$.

Proof. The proof is based upon the fact that $B_X(x, r) \cap S_X$ and $S_X(x, r) \cap S_X$ are closed in S_X , $U_X(x, r) \cap S_X$ is open in S_X , and

$$B_X(x, r) \cap S_X = (U_X(x, r) \cap S_X) \cup (S_X(x, r) \cap S_X).$$

□

The next theorem is the version of Theorem 4.2 for radii strictly between 0 and 2.

THEOREM (5.2). *Let X be a real Banach space. If X is rotund, then X satisfies all the equivalent conditions in the previous proposition for any $x \in S_X$ and any $0 < r < 2$.*

Proof. Assume that X does not satisfy those conditions for some $x \in S_X$ and $0 < r < 2$. Then, $S_X(x, r) \cap S_X$ has non-empty interior relative to S_X . Thus, let $b \in \text{int}_{S_X}(S_X(x, r) \cap S_X)$. Set $Y = \text{span}\{x, b\}$. Obviously, $b \in \text{int}_{S_Y}(S_Y(x, r) \cap S_Y)$. Therefore, by applying Proposition 3.6, we know that $S_Y(x, r) \cap S_Y$ has two path-connected components that are non-trivial segments. This contradicts the fact that X is rotund. □

The previous theorem motivates the following question.

Question (5.3). Let X be a 2-dimensional real Banach space. Assume that X verifies all the equivalent conditions in Proposition 5.1. Is then X rotund?

By means of the next example we will show that the previous question has a negative answer.

Example (5.4). The 2-dimensional real Banach space X whose unit ball is given by

$$B_X := \text{co} \{(-1, 1), (1, 1), (2, 0), (1, -1), (-1, -1), (-2, 0)\}$$

satisfies all the equivalent conditions in Proposition 5.1 but does not satisfy the fact that the set $S_X(x, 2) \cap S_X$ is convex for every $x \in S_X$, and hence it is not rotund.

Now, the previous example motivates the following question.

Question (5.5). Let X be a 2-dimensional real Banach space. Assume that X satisfies all the equivalent conditions in Proposition 5.1 along with the fact that $S_X(x, 2) \cap S_X$ is convex for every $x \in S_X$. Is then X rotund?

Unfortunately, the answer is again negative.

Example (5.6). The 2-dimensional real Banach space X whose unit ball is given by

$$B_X := B_{\ell_2^2}((-1, 0), 1) \cup B_{\ell_\infty^2} \cup B_{\ell_2^2}((1, 0), 1)$$

verifies all the equivalent conditions in Proposition 5.1 along with the fact that $S_X(x, 2) \cap S_X$ is convex for every $x \in S_X$.

Finally, since Proposition 5.1 does not provide us with an equivalent formulation of rotundity, we present the final (and main) theorem of this manuscript, which is the version of Theorem 4.5 for radii strictly between 0 and 2 and characterizes rotundity in 2-dimensional real Banach spaces.

THEOREM (5.7). *Let X be a 2-dimensional real Banach space. The following are equivalent:*

1. X is rotund.
2. If C is a closed, connected subset of S_X such that $\text{diam}(C) > 0$ and $C \neq S_X$, then there exist $x \in S_X$ and $r \in (0, 2)$ satisfying $C = B_X(x, r) \cap S_X$.
3. If U is an open, connected subset of S_X such that $\text{cl}(U) \neq S_X$, then there exist $x \in S_X$ and $r \in (0, 2)$ satisfying $U = \cup_X(x, r) \cap S_X$.

Proof. We will see that (1) and (2) are equivalent. The equivalence of (1) and (3) is similar. Assume that X is rotund. Let C be a closed, connected subset of S_X such that $\text{diam}(C) > 0$ and $C \neq S_X$. Let $a \neq b \in S_X$ such that $\text{bd}_{S_X}(C) = \{a, b\}$. By the connectedness of C , there must be a point $x \in C$ such that $\|x - a\| = \|x - b\|$. Take $r = \|x - a\| = \|x - b\|$. It is clear that $r > 0$ because $a \neq b$. Furthermore, since X is rotund, if $r = 2$, then $a = b = -x$, which is impossible. By Proposition 3.6, $S_X(x, r) \cap S_X$ is composed exactly by two path-connected components which are segments. Since X is rotund, $S_X(x, r) \cap S_X = \{a, b\}$, so, again by Proposition 3.6, $\text{bd}_{S_X}(B_X(x, r) \cap S_X) = \text{bd}_{S_X}(C)$. Furthermore, $\text{int}_{S_X}(B_X(x, r) \cap S_X) \cap \text{int}_{S_X}(C) \supseteq \{x\} \neq \emptyset$, therefore $C = B_X(x, r) \cap S_X$. Assume that condition (2) holds. If X is not rotund, then we can consider a non-trivial segment $[a, b]$ lying on the unit sphere of X . Now, set $C := S_X \setminus (a, b)$. We have that C is a closed, connected subset of S_X such that $\text{diam}(C) > 0$ and $C \neq S_X$. Therefore, there exist $x \in S_X$ and $r \in (0, 2)$

satisfying $C = B_X(x, r) \cap S_X$. Since $r < 2$, we have that $-x \notin B_X(x, r) \cap S_X$, so $-x \in (a, b)$, but then $r = \|x - a\| = 2$ in virtue of Proposition 3.6. \square

Received February 26, 2008

Final version received, April 15, 2009

DEPARTMENT MATHEMATICS,
TEXAS A&M UNIVERSITY,
COLLEGE STATION, TEXAS, 77843-3368,
THE UNITED STATES
fgarcia@math.tamu.edu

REFERENCES

- [JD] J. Diestel: Geometry of Banach spaces-selected topics. Lecture Notes in Mathematics **485**, Springer-Verlag, Berlin-New York, 1975.

THE SPECTRAL MAPPING FORMULA IN ARENS-MICHAEL-FRÈCHET ALGEBRAS

ARMANDO VELÁZQUEZ GONZÁLEZ

ABSTRACT. We consider the left joint spectrum on a unital Arens-Michael-Frèchet algebra B and we prove the spectral mapping formula.

Introduction

The algebras we deal with are complex algebras with unit e and the topological spaces involved are Hausdorff spaces.

Let B be a locally multiplicatively convex algebra (abbreviated lmc algebra) with unit e , and $\aleph = \{U_\alpha\}$ with $\alpha \in \Lambda$ a local basis of B consisting of closed balanced convex absorbing and multiplicative subsets. Consider the respective Minkowski functionals $\Gamma = \{P_\alpha\}$, $\alpha \in \Lambda$, which are continuous seminorms that satisfy

$$P_\alpha(xy) \leq P_\alpha(x)P_\alpha(y) \text{ and } P_\alpha(e) = 1,$$

for all $x, y \in B$ and for every index $\alpha \in \Lambda$.

Let $B_\alpha = B/\ker P_\alpha$ (resp., \widehat{B}_α), $\alpha \in \Lambda$, be the normed (resp., Banach) algebras corresponding to the given local basis \aleph , where \widehat{B}_α is the completion of the normed algebra B_α . Then B is isomorphic to a subalgebra of the cartesian product of normed algebras B_α (Arens-Michael decomposition, see [Ma]). Moreover $\pi_\alpha(B) = B_\alpha$ is dense in \widehat{B}_α for all $\alpha \in \Lambda$, where $\pi_\alpha: B \rightarrow B_\alpha$, $x \rightarrow [x]_\alpha = x + \ker P_\alpha$, is the natural homomorphism of B onto B_α which is open and continuous. A complete lmc algebra is called Arens-Michael algebra (see[He]).

A lmc algebra whose underlying topological vector space is a metrizable and complete space is called a Arens-Michael-Frèchet algebra or Frèchet lmc algebra.

The left joint spectrum of a k -tuple of mutually commuting elements $a_1, \dots, a_k \in B$ is defined as the set of those $\lambda = (\lambda_1, \dots, \lambda_k) \in \mathbb{C}^k$ for which the left ideal generated in B by the elements $a_1 - \lambda_1 e, \dots, a_k - \lambda_k e$ is proper. The left joint spectrum is denoted by $\sigma_B^l(a_1, \dots, a_k)$.

Similarly $\sigma_B^r(a_1, \dots, a_k)$ is defined. The set

$$\sigma_B(a_1, \dots, a_k) = \sigma_B^l(a_1, \dots, a_k) \cup \sigma_B^r(a_1, \dots, a_k)$$

is called the Harte spectrum of a_1, \dots, a_k in B .

2000 *Mathematics Subject Classification*: 46H20.

Keywords and phrases: Arens-Michael-Frèchet algebras, ideal, joint spectrum, spectral mapping formula.

The spectral mapping formula of Harte states that for an arbitrary polynomial mapping $P: \mathbb{C}^k \rightarrow \mathbb{C}^n$,

$$P(\sigma_B(a_1, \dots, a_k)) = \sigma_B(P(a_1, \dots, a_k))$$

and this formula holds for the left and the right spectra separately.

We know that every element of a unital Arens-Michael-Frèchet algebra over \mathbb{C} has a nontrivial spectrum. Section 1 studies the projection property of the family of ideals which in the case of left ideals says that:

if the mutually commuting elements a_1, \dots, a_k generate a proper left ideal in B and if $c \in B$ commutes with all $a_i, 1 \leq i \leq k$, then there exists $\lambda \in \mathbb{C}$ such that the left ideal generated by the elements $a_1, \dots, a_k, c - \lambda e$ is also proper.

In section 2 we prove that the left joint spectrum of a k -tuple of mutually commuting elements $a_1, \dots, a_k \in B$ is nonempty and it satisfies the spectral mapping formula.

Since the case of left and right ideals can be treated similarly, in what follows we consider the left ideals and the left joint spectrum.

1. The projection property

LEMMA (1.1). *Let B be a complex Arens-Michael-Frèchet algebra with unit e and $I_B^l(a_1, \dots, a_k)$ a proper left ideal in B generated by a_1, \dots, a_k . Then the closure of $I_B^l(a_1, \dots, a_k)$ is also proper in B .*

Proof. We consider $I_B^l(a_1, \dots, a_k)$. We claim that there exists $\alpha \in \Lambda$ such that $I_{\widehat{B}_\alpha}^l(\pi_\alpha(a_1), \dots, \pi_\alpha(a_k))$ is the proper left ideal in \widehat{B}_α generated by $\pi_\alpha(a_1), \dots, \pi_\alpha(a_k)$, where π_α is the open and continuous natural homomorphism from B to B_α . Assume the opposite: for all $\alpha \in \Lambda$ $I_{\widehat{B}_\alpha}^l(\pi_\alpha(a_1), \dots, \pi_\alpha(a_k)) = \widehat{B}_\alpha$. Therefore there exist $\tilde{b}_i \in \widehat{B}_\alpha, 1 \leq i \leq k$, such that

$$\sum_{i=1}^k \tilde{b}_i \pi_\alpha(a_i) = e_\alpha$$

for all $\alpha \in \Lambda$, where e_α is the unit of \widehat{B}_α . Then by Theorem 4.2 (see [A]), there exist $b_i \in B$ such that

$$\sum_{i=1}^k b_i a_i = e,$$

and we would have that $e \in I_B^l(a_1, \dots, a_k)$, which is a contradiction.

Since \widehat{B}_α is a unital complex Banach algebra, the closure of $I_{\widehat{B}_\alpha}^l(\pi_\alpha(a_1), \dots, \pi_\alpha(a_k))$ is also proper in \widehat{B}_α . Thus $\pi_\alpha^{-1}(\overline{I_{\widehat{B}_\alpha}^l(\pi_\alpha(a_1), \dots, \pi_\alpha(a_k))})$ is a closed proper left ideal in B . Therefore the closure of $I_B^l(a_1, \dots, a_k)$ is proper in B . \square

THEOREM (1.2). *Let B be a complex Arens-Michael-Frèchet algebra with unit e . Suppose that for every $(k + n)$ -tuple of mutually commuting elements $a_1, \dots, a_k, b_1, \dots, b_n \in B$ the left ideal in B generated by a_1, \dots, a_k is proper in B . Then there exists $\lambda \in \mathbb{C}^n$ such that the left ideal in B generated by $a_1, \dots, a_k, b_1 - \lambda_1 e, \dots, b_n - \lambda_n e$ is proper in B .*

Proof. Let us consider the case $n = 1$. We denote by M the closure of the left ideal in B generated by a_1, \dots, a_k . The ideal M is proper in B thanks to Lemma 1.1.

Let $b = b_1$ commuting with a_1, \dots, a_k and $b \notin M$. Then there exists a submultiplicative seminorm P_α such that

$$\{x \in B : P_\alpha(x - b) < \varepsilon\} \cap M = \emptyset,$$

for some $\varepsilon > 0$. Hence $[b]_\alpha$ is not element of the closure of left ideal $M + \ker P_\alpha = \overline{\pi_\alpha(M)}$.

Since $a_1, \dots, a_k, b \in B$ are mutually commuting elements $[a_1]_\alpha, \dots, [a_k]_\alpha, [b]_\alpha \in B_\alpha \subset \widehat{B}_\alpha$ are also mutually commuting elements. We consider the left ideal in \widehat{B}_α generated by $[a_1]_\alpha, \dots, [a_k]_\alpha$. Since \widehat{B}_α is a complex Banach algebra with unit $[e]_\alpha$, by Harte's Theorem for complex Banach algebras with unit (see [H1]), there exists $\lambda \in \mathbb{C}$ such that

$$(0, \dots, 0, \lambda) \in \sigma_{\widehat{B}_\alpha}^l([a_1]_\alpha, \dots, [a_k]_\alpha, [b]_\alpha).$$

This implies that the left ideal J in \widehat{B}_α generated by $[a_1]_\alpha, \dots, [a_k]_\alpha, [b]_\alpha - [\lambda e]_\alpha$ is proper, whence the closure of J is proper in \widehat{B}_α . The closure of J is a proper ideal in B_α . So $\pi_\alpha^{-1}(\overline{J})$ is a closed proper left ideal in B . Therefore the left ideal in B generated by $a_1, \dots, a_k, b - \lambda e$ is proper in B .

The theorem is proved in the case $n = 1$. One obtains the complete result doing induction over n . □

The right hand side version of this theorem holds also.

2. The spectrum σ_B^l and the spectral mapping formula

THEOREM (2.1). *Let B be a unital Arens-Michael-Frèchet algebra over \mathbb{C} . For an arbitrary $(k + n)$ -tuple of mutually commuting elements $a_1, \dots, a_k, b_1, \dots, b_n \in B$ and for every $(\lambda_1, \dots, \lambda_k) \in \sigma_B^l(a_1, \dots, a_k)$ there exists $(\mu_1, \dots, \mu_n) \in \mathbb{C}^n$ such that*

$$(\lambda_1, \dots, \lambda_k, \mu_1, \dots, \mu_n) \in \sigma_B^l(a_1, \dots, a_k, b_1, \dots, b_n).$$

Proof. This follows from Theorem 1.2 and by definition of left joint spectrum. □

COROLLARY (2.2). *Let B be a unital Arens-Michael-Frèchet algebra over \mathbb{C} . For an arbitrary k -tuple of mutually commuting elements $a_1, \dots, a_k \in B$ the left joint spectrum $\sigma_B^l(a_1, \dots, a_k)$ is nonempty.*

In section 1 of [VW], we proved a purely algebraic fact about the left joint spectrum defined by a family of proper left ideals of a unital algebra (see Theorem 1.1). By that result and Theorem 1.2 we have the spectral mapping formula for $\sigma_B^l(a_1, \dots, a_k)$.

THEOREM (2.3). *Let B be a unital Arens-Michael-Frèchet algebra over \mathbb{C} . Then the family of all finitely generated left ideals in B has the projection property and for all k -tuple of mutually commuting elements $a_1, \dots, a_k \in B$ and for*

every polynomial mapping $P: \mathbb{C}^k \rightarrow \mathbb{C}^n$ the spectral mapping formula

$$P(\sigma_B^l(a_1, \dots, a_k)) = \sigma_B^l(P(a_1, \dots, a_k))$$

holds.

Acknowledgment

I thank Professor Antoni Wawrzyńczyk for his comments and suggestions on this paper.

Received August 1, 2008

Final version received May 13, 2009

UNIVERSIDAD AUTÓNOMA DE LA CIUDAD DE MÉXICO
 COLEGIO DE CIENCIA Y TECNOLOGÍA.
 ACADEMIA DE MATEMÁTICAS
 AV. LA CORONA NO. 320, COL. LOMA LA PALMA
 DEL. GUSTAVO A. MADERO, C.P. 07160, MÉXICO D.F.
 armando_velagon66@yahoo.com.mx

REFERENCES

- [A] R. ARENS, *Dense inverse limit rings*, Michigan Math. J. **5** (1958), 169–182.
- [H1] R. HARTE, *The spectral mapping theorem*, Proc. R.I.A, A **72** (1972), 89–107.
- [H2] R. HARTE, *The spectral mapping theorem in several variables*, Bull. Amer. Math. Soc., **78** (1972), 871–875.
- [He] A. YA. HELEMSKII, *Banach and locally convex algebras*, Oxford Science Publ., New York, 1993.
- [Mi] E. A. MICHAEL, *Locally multiplicatively-convex topological algebras*, Mem. Amer. Math. Soc. **11** (1952).
- [Ma] A. MALLIOS, *Topological algebras. Selected topics*, North-Holland, Amsterdam, 1986.
- [VW] A. VELÁZQUEZ GONZÁLEZ, A. WAWRZYŃCZYK, *Spectral mapping formula for Waelbroeck algebras and their subalgebras*, Contemp. Math. **341**, 127–131, Amer. Math. Soc. Providence, RI, 2004.

RANDOM SOLUTION OF NONLINEAR RANDOM MULTIVALUED OPERATOR INCLUSION

ISMAT BEG AND MUJAHID ABBAS

ABSTRACT. The existence of random fixed points of random multivalued operators satisfying certain contractive conditions is established. The results regarding common random fixed point of a pair of random R -multivalued operators are also obtained. Our work generalizes, refines and improves several earlier known results.

1. Introduction

Random nonlinear analysis has grown into an active research area and is highly associated with the study of random nonlinear operators and their properties which are needed in solving nonlinear random operator equations (see [6]). The study of random fixed point theory was initiated by the Prague school of probabilists in the 1950s ([11], [20]). The survey article by Bharucha-Reid [7] in 1976 attracted the attention of several mathematicians and gave wings to this theory. Itoh [14] extended Spacek's and Hans's theorems to multivalued contraction mappings. At present, the study of the fixed points of random operators of various types is a fascinating discipline for research lying at the intersection of nonlinear analysis and probability theory. In recent year a vast amount of mathematical activities have led to many remarkable new results which establish the existence of random fixed points of certain single valued and multivalued random operators. Various applications of this theory in diverse areas from pure mathematics to applied sciences have also been explored ([2], [3], [4], [5], [17], [21] and references therein). The aim of this paper is to establish the existence of random fixed points of random multivalued operators. This paper contains the results concerning common random fixed points of a pair of random R -multivalued operators. The results proved in this paper improve and generalize the several well known results in existing literature [16], [18] and [21].

2. Preliminaries

We first review some concepts for the convenience of the reader and state the notations used throughout this paper. Let (X, d) be a metric space and let F denote a nonempty subset of (X, d) . Let (Ω, Σ) be a measurable space (Σ is a sigma algebra of subsets of Ω). Let 2^X be the family of all subsets of X , $CB(X)$ all nonempty closed bounded subsets of X and $C(X)$ all nonempty compact

2000 *Mathematics Subject Classification*: 47H09, 47H10, 47H40, 54H25, 60H25.

Keywords and phrases: random fixed point, random R -multivalued operator, measurable selector, metric space, Banach space.

subsets of X respectively. For $A, B \in CB(X)$, $H(A, B)$ denotes the Hausdorff distance between A and B induced by the metric d is given by,

$$H(A, B) = \max\left\{\sup_{a \in A} d(a, B), \sup_{b \in B} d(b, A) : A, B \in CB(X)\right\},$$

where for $x \in X$ and $C \subset X$, $d(x, C) = \inf\{d(x, y) : y \in C\}$ is the distance from the point x to the subset C . A multivalued mapping $T : \Omega \rightarrow 2^X$ (or single valued mapping $T : \Omega \rightarrow X$) is *measurable* if $T^{-1}(U) \in \Sigma$ (or $T^{-1}(U) \in \Sigma$) for each open subset U of X , where $T^{-1}(U) = \{\omega \in \Omega : T(\omega) \cap U \neq \phi\}$. A multivalued mapping $T : \Omega \times F \rightarrow 2^X$ (or single valued mapping $T : \Omega \times F \rightarrow X$) is a *random operator* if and only if for each fixed $x \in F$, the mapping $T(., x) : \Omega \rightarrow 2^X$ (or $T(., x) : \Omega \rightarrow X$) is measurable and it is *continuous* if for each $\omega \in \Omega$, the mapping $T(\omega, .) : F \rightarrow 2^X$ (or $T(\omega, .) : F \rightarrow X$) is continuous. A measurable mapping $\xi : \Omega \rightarrow F$ is a *random fixed point* of a random operator $T : \Omega \times F \rightarrow 2^X$ (or $T : \Omega \times F \rightarrow X$) if and only if it is the random solution of the random operator inclusion $y(\omega) \in T(\omega, y(\omega))$ (or it is the random solution of the random operator equation $y(\omega) = T(\omega, y(\omega))$) for each $\omega \in \Omega$. We denote the set of random fixed points of a random operator T by $RF(T)$ and the set of all measurable mappings from Ω into X by $M(\Omega, X)$.

Let $B(x_0, r)$ denotes the spherical ball centered at x_0 with radius r , defined as the set $\{x \in X : d(x, x_0) \leq r\}$. We denote the n -th iterate $T(\omega, T(\omega, T(\omega, \dots, T(\omega, x) \dots)))$ of the random operator $T : \Omega \times F \rightarrow F$ by $T^n(\omega, x)$. The letter I denotes the random operator $I : \Omega \times F \rightarrow F$ defined by $I(\omega, x) = x$ and $T^0 = I$.

Definition (2.1). Let F be a nonempty subset of a separable metric space X . The random operator $T : \Omega \times F \rightarrow F$ is said to be a *random $k(\omega)$ -contraction operator* if for any $x, y \in F$ and $\omega \in \Omega$, we have

$$d(T(\omega, x), T(\omega, y)) \leq k(\omega)d(x, y),$$

where k is a mapping from Ω into $[0, 1)$. If $k(\omega) = 1$ for any $\omega \in \Omega$, then T is called a *random nonexpansive operator*.

Definition (2.2) ([18]). Let F be a nonempty subset of X . A map $T : F \rightarrow 2^X$ is said to be *R-multivalued map* if there exists positive real numbers α, β, γ with $\alpha + \beta + \gamma < 1$ such that for each $x \in X$, any $u_x \in T(x)$ and for all $y \in X$, there is $u_y \in T(y)$ so that we have

$$d(u_x, u_y) \leq \alpha d(x, y) + \beta d(x, u_x) + \gamma d(y, u_y).$$

Taking $\alpha = 0$ and $\beta = \gamma = h$, ($0 \leq h < \frac{1}{2}$), we obtain a *K-multivalued operator*, which was introduced by Latif and Beg [16]. A random operator $T : \Omega \times F \rightarrow 2^X$ is said to be a *random R-multivalued operator* (random *K-multivalued operator*) if $T(\omega, .)$ is a *R-multivalued map* (*K-multivalued map*) for each $\omega \in \Omega$.

Definition (2.3). Let F be a nonempty subset of X . A pair of maps $T, S : F \rightarrow 2^X$ is said to be an *R-multivalued pair* if there exists positive real numbers α, β, γ with $\alpha + \beta + \gamma < 1$ such that for each $x \in X$, any $u_x \in T(x)$ and for all $y \in X$, there is $u_y \in S(y)$ so that we have

$$d(u_x, u_y) \leq \alpha d(x, y) + \beta d(x, u_x) + \gamma d(y, u_y).$$

A pair of random operators $T, S: \Omega \times F \rightarrow 2^X$ is said to be a *random R-multivalued pair* of operators if $T(\omega, \cdot)$ and $S(\omega, \cdot)$ form an R -multivalued pair of maps for each $\omega \in \Omega$.

Definition (2.4). Let F be a nonempty subset of X . A pair of maps $T, S: F \rightarrow 2^X$ is said to be a *K-multivalued pair* if there exists a positive real number h with $0 \leq h < \frac{1}{2}$ such that for each $x \in X$, any $u_x \in T(x)$ and for all $y \in X$, there is $u_y \in S(y)$ so that we have

$$d(u_x, u_y) \leq h[d(x, u_x) + d(y, u_y)].$$

A pair of random operators $T, S: \Omega \times F \rightarrow 2^X$ is said to be a *random K-multivalued pair* of operators if $T(\omega, \cdot)$ and $S(\omega, \cdot)$ form a K -multivalued pair of maps for each $\omega \in \Omega$.

Remark (2.5). Let F be a closed subset of a separable complete metric space X and let the sequence of measurable mappings $\{\xi_n\}$ from Ω into F be pointwise convergent, that is, $\xi_n(\omega) \rightarrow q := \xi(\omega)$ for each $\omega \in \Omega$. Then ξ being the limit of the sequence of measurable mappings is measurable, and closedness of F implies ξ is a mapping from Ω into F . Since F is a subset of a complete separable metric space X , also if T is a continuous random operator from $\Omega \times F$ into F then by the lemma 8.2.3 of [1], the map $\omega \rightarrow T^n(\omega, f(\omega))$ is measurable for any measurable mapping f from Ω into F . For further details see [12].

Definition (2.6). A random operator $T: \Omega \times X \rightarrow 2^X$ is called a *random multivalued weakly dissipative operator* if there exists a random map $\varphi: \Omega \times X \rightarrow R$ such that for all $x \in X$, there is $y \in T(\omega, x)$ for each $\omega \in \Omega$ satisfying the inequality

$$d(x, y) < \varphi(\omega, x) - \varphi(\omega, y), \text{ for every } \omega \in \Omega.$$

In the next definition, X denotes a gauge space endowed with a complete gauge structure induced by a family $\{d_\alpha : \alpha \in \Lambda\}$ of pseudometrics, where Λ is a directed set. Basic definitions and properties of gauge space may be found in [8]. We denote by H_α the generalized Hausdorff pseudometric induced by d_α .

Definition (2.7). A multivalued map $T: X \rightarrow 2^X$ is called an *admissible contractive map* with $\{k_\alpha\} \subseteq [0, 1)$ if

- (i) for every $\alpha \in \Lambda$, $H_\alpha(T(x), T(y)) \leq k_\alpha d_\alpha(x, y)$ for every $x, y \in X$
- (ii) for every $x \in X$ and every $\{\varepsilon_\alpha\} \subseteq (0, \infty)$, there is $y \in T(x)$ such that $d_\alpha(x, y) \leq d_\alpha(x, T(x)) + \varepsilon_\alpha$ for every $\alpha \in \Lambda$

A random operator $T: \Omega \times X \rightarrow 2^X$ is called a *random multivalued admissible contractive operator* if $T(\omega, \cdot)$ is an admissible contractive map for each $\omega \in \Omega$.

3. Random fixed points of random multivalued operators

In this section, we obtain the random fixed point theorems for random multivalued operators satisfying certain contractive conditions.

THEOREM (3.1). *Let X be a separable complete gauge space and $T: \Omega \times X \rightarrow CB(X)$ be an admissible contractive random operator. If $\xi_0: \Omega \rightarrow X$ is any fixed measurable mapping such that $d_\alpha(\xi_0(\omega), T(\omega, \xi_0(\omega))) < (1 - k_\alpha(\omega))r_\alpha(\omega)$ for each*

$\alpha \in \Lambda$ and $\omega \in \Omega$, where $\{r_\alpha(\omega)\} \subseteq (0, \infty)$ for each $\omega \in \Omega$, then T has a random fixed point.

Proof. Choose $\xi_1 \in M(\Omega, X)$ such that $\xi_1(\omega) \in T(\omega, \xi_0(\omega))$ for each $\omega \in \Omega$. Consider the measurable mapping $\omega \rightarrow T(\omega, \xi_0(\omega))$ from Ω to $CB(X)$. The existence of a measurable mapping $\xi_1: \Omega \rightarrow X$ is due to Kuratowski and Ryll-Nardzewski [15]. By the definition,

$$d_\alpha(\xi_0(\omega), \xi_1(\omega)) < (1 - k_\alpha(\omega))r_\alpha(\omega), \quad \text{for each } \alpha \in \Lambda \text{ and } \omega \in \Omega.$$

Similarly choose $\xi_2 \in M(\Omega, F)$ such that $\xi_2(\omega) \in T(\omega, \xi_1(\omega))$, for each $\omega \in \Omega$,

$$\begin{aligned} d_\alpha(\xi_1(\omega), \xi_2(\omega)) &< d_\alpha(\xi_1(\omega), T(\omega, \xi_1(\omega))) + k_\alpha(\omega)[(1 - k_\alpha(\omega))r_\alpha(\omega) \\ &\quad - d_\alpha(\xi_0(\omega), \xi_1(\omega))] \\ &\leq H_\alpha(T(\omega, \xi_0(\omega)), T(\omega, \xi_1(\omega))) + k_\alpha(\omega)[(1 - k_\alpha(\omega))r_\alpha(\omega) \\ &\quad - d_\alpha(\xi_0(\omega), \xi_1(\omega))] \\ &\leq k_\alpha(\omega)d_\alpha(\xi_0(\omega), \xi_1(\omega)) + k_\alpha(\omega)[(1 - k_\alpha(\omega))r_\alpha(\omega) \\ &\quad - d_\alpha(\xi_0(\omega), \xi_1(\omega))] \\ &= k_\alpha(\omega)(1 - k_\alpha(\omega))r_\alpha(\omega), \quad \text{for each } \alpha \in \Lambda \text{ and } \omega \in \Omega. \end{aligned}$$

Continuing this process we obtain a sequence of measurable maps $\{\xi_n\}$ such that for every $\omega \in \Omega$ we have

$$d_\alpha(\xi_n(\omega), \xi_{n+1}(\omega)) \leq (k_\alpha(\omega))^n(1 - k_\alpha(\omega))r_\alpha(\omega), \quad \text{for each } \alpha \in \Lambda.$$

Now $\{\xi_n(\omega)\}$ is a Cauchy sequence in X for every ω in Ω . Since X is complete, therefore $\xi_n(\omega) \rightarrow p(\omega)$ for every $\omega \in \Omega$, $p: \Omega \rightarrow X$ being a limit of sequence of measurable functions is also measurable. The continuity of T implies p is a solution of random operator inclusion $x(\omega) \in T(\omega, x(\omega))$ for each ω in Ω . \square

THEOREM (3.2). *Let X be a separable complete metric space and let $T: \Omega \times X \rightarrow 2^X$ be a random weakly dissipative demiclosed multivalued operator assuming closed values. Then T has a random fixed point.*

Proof. Let $\xi_0: \Omega \rightarrow X$ be any fixed measurable mapping and $\xi_1: \Omega \rightarrow X$ be a measurable mapping such that $\xi_1(\omega) \in T(\omega, \xi_0(\omega))$ for each $\omega \in \Omega$. The measurable mapping $\xi_1: \Omega \rightarrow X$ can be obtained by applying the selection theorem due to Kuratowski and Ryll-Nardzewski [15]. Now

$$d(\xi_0(\omega), \xi_1(\omega)) < \varphi(\omega, \xi_0(\omega)) - \varphi(\omega, \xi_1(\omega)),$$

for every ω in Ω . Continuing in this way we obtain a sequence of measurable mappings $\xi_n: \Omega \rightarrow X$ such that $\xi_n(\omega) \in T(\omega, \xi_{n-1}(\omega))$ for every ω in Ω . Now for $q \geq p$, we have

$$d(\xi_p(\omega), \xi_q(\omega)) \leq \sum_{n=p}^{q-1} d(\xi_n(\omega), \xi_{n+1}(\omega)) \leq \varphi(\omega, \xi_p(\omega)) - \varphi(\omega, \xi_q(\omega)),$$

for every $\omega \in \Omega$ since, $\{\varphi(\omega, \xi_n(\omega))\}$ is a non increasing and bounded below sequence of real numbers for each ω in Ω . Now $\{\xi_n(\omega)\}$ is a Cauchy sequence for every $\omega \in \Omega$. By completeness of the space X , there exists $\xi(\omega) \in X$ for each ω in Ω such that $d(\xi_n(\omega), \xi(\omega)) \rightarrow 0$ as $n \rightarrow \infty$ (The mapping $\xi: \Omega \rightarrow X$ is a pointwise limit of a sequence of measurable mappings $\{\xi_n\}$, therefore it is

measurable). Now construction of the sequence of measurable mappings and demiclosedness of T implies the existence of stochastic solution to the random operator inclusion $x(\omega) \in T(\omega, x(\omega))$ for every $\omega \in \Omega$. \square

Latif and Beg [16] coined the notion of K -multivalued maps and proved some fixed points theorems for such maps. Recently, Rus et al. [18] defined a new class of R -multivalued maps which contains K -multivalued maps. Now, we prove the set of random fixed points of K -multivalued random operator is nonempty.

THEOREM (3.3). *Let X be a separable complete metric space and let $T: \Omega \times X \rightarrow 2^X$ be a random K -multivalued operator assuming closed values. Then T has a random fixed point.*

Proof. Let $\xi_0: \Omega \rightarrow X$ be any fixed measurable mapping and $\xi_1: \Omega \rightarrow X$ be a measurable mapping such that $\xi_1(\omega) \in T(\omega, \xi_0(\omega))$, for each $\omega \in \Omega$. The existence of a measurable mapping $\xi_1: \Omega \rightarrow X$ is due to Kuratowski and Ryll-Nardzewski [15]. Choose a measurable mapping $\xi_2: \Omega \rightarrow X$ such that $\xi_2(\omega) \in T(\omega, \xi_1(\omega))$, for each $\omega \in \Omega$. Since $T(\omega, \cdot)$ is random K -multivalued operator for each $\omega \in \Omega$, therefore

$$d(\xi_1(\omega), \xi_2(\omega)) \leq h(\omega)[d(\xi_0(\omega), \xi_1(\omega)) + d(\xi_1(\omega), \xi_2(\omega))],$$

which gives

$$d(\xi_1(\omega), \xi_2(\omega)) \leq \frac{h(\omega)}{1 - h(\omega)} d(\xi_0(\omega), \xi_1(\omega)),$$

for each $\omega \in \Omega$ and $h: \Omega \rightarrow [0, \frac{1}{2})$. Continuing in this way we form a sequence of measurable mappings $\xi_n: \Omega \rightarrow X$ such that $\xi_{n+1}(\omega) \in T(\omega, \xi_n(\omega))$ for every ω in Ω and

$$d(\xi_n(\omega), \xi_{n+1}(\omega)) \leq \left[\frac{h(\omega)}{1 - h(\omega)} \right]^n d(\xi_0(\omega), \xi_1(\omega)),$$

for every $\omega \in \Omega$. Put $\lambda(\omega) = \frac{h(\omega)}{1 - h(\omega)}$, then $0 \leq \lambda(\omega) < 1$. Therefore

$$d(\xi_n(\omega), \xi_{n+1}(\omega)) \leq [\lambda(\omega)]^n d(\xi_0(\omega), \xi_1(\omega)),$$

for every ω in Ω . Now $\{\xi_n(\omega)\}$ is a Cauchy sequence in X for every $\omega \in \Omega$. Indeed, let ω be an arbitrary fixed point, let $m < n$, we have

$$d(\xi_m(\omega), \xi_n(\omega)) \leq \sum_{i=m}^{n-1} (\lambda(\omega))^i d(\xi_1(\omega), \xi_0(\omega)).$$

Thus $\{\xi_n(\omega)\}$ is a Cauchy sequence in X for each $\omega \in \Omega$. By completeness of the space X , there exists $\xi(\omega) \in X$ for each ω in Ω such that $d(\xi_n(\omega), \xi(\omega)) \rightarrow 0$ as $n \rightarrow \infty$ (The mapping $\xi: \Omega \rightarrow X$ is a pointwise limit of measurable mappings $\{\xi_n\}$, therefore it is measurable). Choosing $\{\xi_n(\omega)\} \subseteq T(\omega, \xi(\omega))$ and employing the fact that $T(\omega, \cdot)$ is random K -multivalued operator for each $\omega \in \Omega$ we have $d(\xi_n(\omega), \xi(\omega)) \rightarrow 0$, as $n \rightarrow \infty$ since $T(\omega, \xi(\omega))$ is closed subset of X for each ω in Ω . So the result follows. \square

THEOREM (3.4). *Let X be a complete separable metric space and let $T: \Omega \times X \rightarrow 2^X$ be a R -multivalued random operator assuming closed values. Then T has a random fixed point.*

Proof. Let $\xi_0: \Omega \rightarrow X$ be any fixed measurable mapping and $\xi_1: \Omega \rightarrow X$ be a measurable mapping such that $\xi_1(\omega) \in T(\omega, \xi_0(\omega))$, for each $\omega \in \Omega$. The existence of a measurable mapping $\xi_1: \Omega \rightarrow X$ is due to the selection theorem of Kuratowski and Ryll-Nardzewski [15]. Choose a measurable mapping $\xi_2: \Omega \rightarrow X$ such that $\xi_2(\omega) \in T(\omega, \xi_1(\omega))$, for each $\omega \in \Omega$. Since $T(\omega, \cdot)$ is a random R -multivalued operator for each $\omega \in \Omega$, therefore

$$d(\xi_1(\omega), \xi_2(\omega)) \leq \alpha(\omega)d(\xi_0(\omega), \xi_1(\omega)) + \beta(\omega)d(\xi_0(\omega), \xi_1(\omega)) + \gamma(\omega)d(\xi_1(\omega), \xi_2(\omega)),$$

for each $\omega \in \Omega$. Thus for every ω in Ω , we have

$$d(\xi_1(\omega), \xi_2(\omega)) \leq \lambda(\omega)d(\xi_0(\omega), \xi_1(\omega)),$$

where, $\lambda(\omega) = \frac{\alpha(\omega) + \beta(\omega)}{1 - \gamma(\omega)} < 1$, for each $\omega \in \Omega$. Continuing in this way we form a sequence of measurable mappings $\xi_n: \Omega \rightarrow X$ such that

$$d(\xi_n(\omega), \xi_{n+1}(\omega)) \leq (\lambda(\omega))^n d(\xi_0(\omega), \xi_1(\omega)),$$

for every $\omega \in \Omega$. Thus $\{\xi_n(\omega)\}$ is a Cauchy sequence in X for every $\omega \in \Omega$. Indeed, let ω be an arbitrary fixed point, let $m < n$,

$$\begin{aligned} d(\xi_{m+1}(\omega), \xi_n(\omega)) &\leq d(\xi_{m+1}(\omega), \xi_{m+2}(\omega)) + d(\xi_{m+2}(\omega), \xi_{m+3}(\omega)) \\ &\quad + \dots + d(\xi_{n-1}(\omega), \xi_n(\omega)) \\ &\leq \sum_{i=m}^{n-1} \lambda^i(\omega) d(\xi_1(\omega), \xi_0(\omega)). \end{aligned}$$

Thus, $\{\xi_n(\omega)\}$ is a Cauchy sequence in X for each $\omega \in \Omega$. By completeness of the space X , there exists $\xi(\omega) \in X$ for each ω in Ω such that $d(\xi_n(\omega), \xi(\omega)) \rightarrow 0$, as $n \rightarrow \infty$ (The mapping $\xi: \Omega \rightarrow X$ is a pointwise limit of measurable mappings $\{\xi_n\}$, therefore it is measurable). Choosing $\{\xi_n(\omega)\} \subseteq T(\omega, \xi(\omega))$ and employing the fact that $T(\omega, \cdot)$ is a random R -multivalued operator for each $\omega \in \Omega$, we have $d(\xi_n(\omega), \xi(\omega)) \rightarrow 0$, as $n \rightarrow \infty$ since $T(\omega, \xi(\omega))$ is closed subset of X for each ω in Ω . So ξ is a random fixed point of T . \square

4. Common random fixed point of random R -multivalued pair of operators

In this section the existence of common random fixed point of random K -multivalued pair of operators is also established. Finally, we gave the stochastic version of a result of Rus et al. [18].

THEOREM (4.1). *Let X be a separable complete metric space and $T_1, T_2: \Omega \times X \rightarrow 2^X$ form a random K -multivalued pair of operators assuming closed values. Then T_1 and T_2 have a common random fixed point.*

Proof. Let $\xi_0: \Omega \rightarrow X$ be any fixed measurable mapping and $\xi_1: \Omega \rightarrow X$ be a measurable mapping such that $\xi_1(\omega) \in T_1(\omega, \xi_0(\omega))$, for each $\omega \in \Omega$. The existence of a measurable mapping $\xi_1: \Omega \rightarrow X$ follows by Kuratowski and Ryll-Nardzewski [15]. Choose a measurable mapping $\xi_2: \Omega \rightarrow X$ such that $\xi_2(\omega) \in T_2(\omega, \xi_1(\omega))$, for each $\omega \in \Omega$ since $T_1(\omega, \cdot)$ and $T_2(\omega, \cdot)$ form a random K -multivalued pair of operators for each $\omega \in \Omega$, therefore

$$d(\xi_1(\omega), \xi_2(\omega)) \leq \lambda(\omega)d(\xi_0(\omega), \xi_1(\omega)),$$

for each $\omega \in \Omega$ where, $0 \leq \lambda(\omega) = \frac{h(\omega)}{1 - h(\omega)} < 1$, for every $\omega \in \Omega$. Continuing in this way we form a sequence of measurable mappings $\xi_n: \Omega \rightarrow X$ such that $\xi_{2n-1}(\omega) \in T_1(\omega, \xi_{2n-2}(\omega))$ and $\xi_{2n}(\omega) \in T_2(\omega, \xi_{2n-1}(\omega))$ for every ω in Ω and

$$d(\xi_n(\omega), \xi_{n+1}(\omega)) \leq [\lambda(\omega)]^n d(\xi_0(\omega), \xi_1(\omega)),$$

for every $\omega \in \Omega$. Now $\{\xi_n(\omega)\}$ is a Cauchy sequence for every $\omega \in \Omega$, as shown in the previous theorem. By completeness of the space X , there exists $\xi(\omega) \in X$ for each ω in Ω such that $d(\xi_n(\omega), \xi(\omega)) \rightarrow 0$, as $n \rightarrow \infty$ (The mapping $\xi: \Omega \rightarrow X$ is a pointwise limit of measurable mappings $\{\xi_n\}$, therefore it is measurable) since $\xi_{2n}(\omega) \in T_2(\omega, \xi_{2n-1}(\omega))$ for every $\omega \in \Omega$. Choosing $\{\zeta_n(\omega)\} \subseteq T_1(\omega, \xi(\omega))$ and employing the fact that $T_1(\omega, \cdot)$ and $T_2(\omega, \cdot)$ form a pair of random K -multivalued operators for each $\omega \in \Omega$, we have $d(\zeta_n(\omega), \xi(\omega)) \rightarrow 0$, as $n \rightarrow \infty$ since $T_1(\omega, \xi(\omega))$ is closed subset of X for each ω in Ω . So ξ is the random fixed point of T_1 . Now we show that $RF(T_1) = RF(T_2)$. Let $\xi_1: \Omega \rightarrow X$ be the random fixed point of T_1 , that is $\xi_1(\omega) \in T(\omega, \xi_1(\omega))$, for each $\omega \in \Omega$. Let $\xi_2: \Omega \rightarrow X$ be the measurable selection of $T_2(\omega, \xi_1(\omega))$, exploiting the fact that T_1 and T_2 form a random K -multivalued pair of operators, we have $\xi_1(\omega) = \xi_2(\omega)$, for every ω in Ω . Hence the result follows. □

THEOREM (4.2). *Let X be a separable complete metric space and let $T_1, T_2: \Omega \times X \rightarrow 2^X$ form a random R -multivalued pair of operators assuming closed values. Then T_1 and T_2 have a common random fixed point.*

Proof. Let $\xi_0: \Omega \rightarrow X$ be any fixed measurable mapping and $\xi_1: \Omega \rightarrow X$ be a measurable mapping such that $\xi_1(\omega) \in T_1(\omega, \xi_0(\omega))$, for each $\omega \in \Omega$. The existence of a measurable mapping $\xi_1: \Omega \rightarrow X$ is due to the selection theorem of Kuratowski and Ryll-Nardzewski [15]. Choose a measurable mapping $\xi_2: \Omega \rightarrow X$ such that $\xi_2(\omega) \in T_2(\omega, \xi_1(\omega))$, for each $\omega \in \Omega$ since $T_1(\omega, \cdot)$ and $T_2(\omega, \cdot)$ form a random R -multivalued pair of operators for each $\omega \in \Omega$, therefore

$$d(\xi_1(\omega), \xi_2(\omega)) \leq \lambda(\omega)d(\xi_0(\omega), \xi_1(\omega)),$$

for each $\omega \in \Omega$ where $0 \leq \lambda(\omega) = \frac{\alpha(\omega) + \beta(\omega)}{1 - \gamma(\omega)} < 1$ for every $\omega \in \Omega$. Continuing in this manner we obtain a sequence of measurable mappings $\xi_n: \Omega \rightarrow X$ such that $\xi_{2n-1}(\omega) \in T_1(\omega, \xi_{2n-2}(\omega))$ and $\xi_{2n}(\omega) \in T_2(\omega, \xi_{2n-1}(\omega))$ and

$$d(\xi_n(\omega), \xi_{n+1}(\omega)) \leq [\lambda(\omega)]^n d(\xi_0(\omega), \xi_1(\omega)),$$

for every $\omega \in \Omega$. Now $\{\xi_n(\omega)\}$ is a Cauchy sequence for every $\omega \in \Omega$. By completeness of the space X , there exists $\xi(\omega) \in X$ for each ω in Ω such that $d(\xi_n(\omega), \xi(\omega)) \rightarrow 0$ as $n \rightarrow \infty$ (The mapping $\xi: \Omega \rightarrow X$ being a pointwise limit of a sequence of measurable mappings $\{\xi_n\}$ is measurable). Since $\xi_{2n}(\omega) \in T_2(\omega, \xi_{2n-1}(\omega))$ for every $\omega \in \Omega$. Choosing $\{\zeta_n(\omega)\} \subseteq T_1(\omega, \xi(\omega))$ and employing the fact that $T_1(\omega, \cdot)$ and $T_2(\omega, \cdot)$ form a random R -multivalued pair of operators for each $\omega \in \Omega$, we have $d(\zeta_n(\omega), \xi(\omega)) \rightarrow 0$ as $n \rightarrow \infty$ since $T_1(\omega, \xi(\omega))$ is closed subset of X for each ω in Ω . So ξ is a random fixed point of T_1 . Now we show that $RF(T_1) = RF(T_2)$. Let $\xi_1: \Omega \rightarrow X$ be the random fixed point of T_1 , that is $\xi_1(\omega) \in T(\omega, \xi_1(\omega))$, for each $\omega \in \Omega$. Let $\xi_2: \Omega \rightarrow X$ be the measurable selection of $T_2(\omega, \xi_1(\omega))$, exploiting the fact that $T_1(\omega, \cdot)$ and

$T_2(\omega, \cdot)$ form a random K -multivalued pair of operators, we have $\xi_1(\omega) = \xi_2(\omega)$ for every ω in Ω . Hence the result follows. \square

Acknowledgment

The present version of the paper owes much to the precise and kind remarks of two anonymous referees.

Received May 8, 2007

Final version received April 27, 2008

CENTRE FOR ADVANCED STUDIES IN MATHEMATICS,
LAHORE UNIVERSITY OF MANAGEMENT SCIENCES,
54792-LAHORE,
PAKISTAN.
ibeg@lums.edu.pk

REFERENCES

- [1] J. P. AUBIN and H. FRANKOWSKA, *Set-Valued Analysis*, Birkhauser, Boston, (1990).
- [2] I. BEG, *Minimal displacement of random variables under Lipschitz random maps*, *Topol. Methods Nonlinear Anal.*, **19** (2002), 391–397.
- [3] I. BEG and M. ABBAS, *Iterative procedures for solution of random equations in Banach spaces*, *J. Math. Anal. Appl.*, **315** (1)(2006), 181–201.
- [4] I. BEG, A. R. KHAN and N. HUSSAIN, *Approximations of *-nonexpansive random multivalued operators on Banach spaces*, *J. Austral. Math. Soc.*, **76** (2004), 51–66.
- [5] T. D. BENAVIDES, G. L. ACEDO and H. K. XU, *Random fixed points of set valued operators*, *Proc. Amer. Math. Soc.*, **124** (3) (1996), 831–838.
- [6] A. T. BHARUCHA-REID, *Random Integral Equations*, Academic Press, New York and London, (1972).
- [7] A. T. BHARUCHA-REID, *Fixed point theorems in probabilistic analysis*, *Bull. Amer. Math. Soc.*, **82** (1976), 641–645.
- [8] J. DUGUNDJI, *Topology*, Wm. C. Brown Publisher, Dubuque, (1989).
- [9] M. FRIGON, *Fixed point results for generalized contraction in Gauge spaces and applications*, *Proc. Amer. Math. Soc.*, **128** (2000), 3275–3283.
- [10] L. GÓRNIOWICZ, *Topological Fixed Point Theory of Multivalued Mappings*, Kluwer, Dordrecht, (1999).
- [11] O. HANŠ, *Reduzierende zufällige transformationen*, *Czechoslovak Math. J.*, **7** (1957), 154–158.
- [12] C. J. HIMMELBERG, *Measurable relations*, *Fund. Math.*, **87** (1975), 53–72.
- [13] S. ITOH, *A random fixed point theorem for a multivalued contraction mapping*, *Pacific J. Math.*, **68** (1977), 85–90.
- [14] S. ITOH, *Random fixed point theorems with an application to random differential equations in Banach spaces*, *J. Math. Anal. Appl.*, **67** (1979), 261–273.
- [15] K. KURATOWSKI and C. RYLL-NARDZEWSKI, *A general theorem on selectors*, *Bull. Acad. Polon. Sci. Ser. Sci. Math. Astronom. Phys.*, **13** (1965), 397–403.
- [16] A. LATIF and I. BEG, *Geometric fixed points for single and multivalued mappings*, *Demonstratio Math.* **30** (1997), 791–800.
- [17] N. S. PAPAGEORGIU, *Random fixed point theorems for measurable multifunctions in Banach spaces*, *Proc. Amer. Math. Soc.*, **97** (1986), 507–514.
- [18] I. A. RUS, A. PETRUSEL and A. SINTAMARIAN, *Data dependence of the fixed point set of some multivalued weakly Picard operators*, *Nonlinear Analysis*, **52** (2003), 1947–1959.
- [19] S. P. SINGH and B. WATSON, *Proximity maps and fixed points*, *J. Approx. Theory*, **39** (1983), 72–76.
- [20] A. SPACEK, *Zufällige Gleichungen*, *Czechoslovak Math. J.*, **5** (1955), 462–466.
- [21] H. K. XU and I. BEG, *Measurability of fixed point sets of multivalued random operators*, *J. Math. Anal. Appl.*, **225** (1998), 62–72.

INEQUALITIES FOR A GENERALIZATION OF INTERSECTION BODIES

ZHAO LINGZHI AND SHEN YAJUN

ABSTRACT. In this paper, we establish the monotonicity for a generalized class of intersection bodies and give a generalization of the Funk section theorem.

1. Introduction

Let $L \subset \mathbb{R}^n$ be a star body, that is, a compact set which is star-shaped with respect to the origin and has a continuous radial function, $\rho(L, u) = \rho_L(u) = \max\{\lambda \geq 0 : \lambda u \in L\}$, $u \in S^{n-1}$. The intersection body, IL , of L is the star body whose radial function in the direction $u \in S^{n-1}$ is equal to the $(n - 1)$ -dimensional volume of the section of L by u^\perp , the hyperplane orthogonal to u . So, for $u \in S^{n-1}$,

$$(1.1) \quad \rho(IL, u) = \text{vol}(L \cap u^\perp),$$

where vol denotes $(n - 1)$ -dimensional volume.

The notion of intersection body has shown to be fundamentally connected to the Busemann-Petty problem (first posed in [2]): Given two centrally-symmetric star bodies K and L in \mathbb{R}^n satisfying:

$$(1.2) \quad \text{vol}(K \cap u^\perp) \leq \text{vol}(L \cap u^\perp)$$

for all $u \in S^{n-1}$. Does it follow that $V(K) \leq V(L)$?

The answer is affirmative if $n \leq 4$ and negative if $n \geq 5$. The solution appeared as the result of a sequence of papers [1], [2], [3], [5], [6], [7], [9], [10], [13], [16] (see [16] for historical details). In [11], Lutwak proved that the Busemann-Petty problem has a positive answer if K is an intersection body in \mathbb{R}^n :

THEOREM (A). *Let K be an intersection body and L be a star body in \mathbb{R}^n . If*

$$\text{vol}(K \cap u^\perp) \leq \text{vol}(L \cap u^\perp)$$

for all $u \in S^{n-1}$, then

$$V(K) \leq V(L),$$

with equality if and only if $K = L$.

2000 *Mathematics Subject Classification*: 52A20, 52A40.

Keywords and phrases: star body, generalized intersection body, Radon transform.

Research is supported in part by the Science and Technology Research Item of Zhejiang Provincial Department of Education. (No. 20070935).

The Funk section theorem [4], [8] shows that the operator I is injective when restricted to centered star bodies. that is, if K and L are centered star bodies, then

$$IK = IL \Rightarrow K = L.$$

In [12], Lv and Leng established an extension of the Funk section theorem as follows:

THEOREM (B). *Let K be centered star body and L be star body in \mathbb{R}^n . If*

$$IK = IL,$$

then

$$V(K) \leq V(L),$$

with equality if and only if $K = L$.

In [15], Zhang introduced a generalized class of intersection bodies: If L be is a star body in \mathbb{R}^n and $1 \leq i \leq n - 1$, the generalized class of intersection bodies of L are the centered star body I_iL such that

$$(1.3) \quad \rho_{I_iL}(u) = \frac{1}{n-1} \int_{S^{n-1} \cap u^\perp} \rho_L(v)^i dv$$

for all $u \in S^{n-1}$. By (1.1), (1.3) and the polar coordinate formula for volume, we have $I_{n-1}L = IL$.

In this paper, we extend above two theorems to the generalized class of intersection bodies. Let $\widetilde{W}_i(K)$ denote the dual quermassintegral of K (please see next section for definition). Our main results can be stated as follows:

THEOREM (1.4). *Let K be an intersection body and L be a star body in \mathbb{R}^n . If*

$$I_iK \subseteq I_iL,$$

then

$$\widetilde{W}_{n-1-i}(K) \leq \widetilde{W}_{n-1-i}(L), \quad \text{for } 1 \leq i \leq n - 1,$$

with equality if and only if $K = L$.

THEOREM (1.5). *Let K be centered star body and L be star body in \mathbb{R}^n . If*

$$I_iK = I_iL,$$

then

$$\widetilde{W}_{n-1-i}(K) \leq \widetilde{W}_{n-1-i}(L) \quad \text{for } 1 \leq i \leq n - 1,$$

with equality if and only if $K = L$.

Remark (1.6). Let $i = n - 1$ in theorem (1.4) and theorem (1.5), then we get theorem (A) and theorem (B) immediately.

2. Notation and preliminary works

As usual, S^{n-1} denotes the unit sphere, B_n the unit ball in Euclidean n -space \mathbb{R}^n . The set of real-valued, continuous functions on S^{n-1} will be denoted by $C(S^{n-1})$. The subset of $C(S^{n-1})$ that contains the even functions will be denoted by $C_e(S^{n-1})$. The subset of $C_e(S^{n-1})$ that contains the nonnegative functions shall be denoted by $C_e^+(S^{n-1})$. The subset of $C_e(S^{n-1})$ that contains the infinitely differentiable functions will be denoted by $C_e^\infty(S^{n-1})$.

If $f, g \in C(S^{n-1})$, then we define $\langle f, g \rangle$ by

$$(2.1) \quad \langle f, g \rangle = \frac{1}{n} \int_{S^{n-1}} f(u)g(u)du.$$

We shall use $|\cdot|_2$ to denote the norm on $C(S^{n-1})$ induced by this inner product; i.e., for $f \in C(S^{n-1})$, $|f|_2 = \sqrt{\langle f, f \rangle}$.

For a given function $f \in C_e(S^{n-1})$, the Radon transform [11] of f on S^{n-1} , Rf , defined by

$$(2.2) \quad (Rf)(u) = \frac{1}{n-1} \int_{S^{n-1} \cap u^\perp} f(v)dv$$

for $u \in S^{n-1}$.

It is well known that the linear transformation

$$R: C_e(S^{n-1}) \rightarrow C_e(S^{n-1}),$$

is self-adjoint, i.e., if $f, g \in C_e(S^{n-1})$, then

$$(2.3) \quad \langle Rf, g \rangle = \langle f, Rg \rangle.$$

From the definition of the generalized class of intersection bodies (1.3) and Radon transform we have $\rho_{I,K}$ equals the Radon transform of ρ_K^i , that is,

$$(2.4) \quad \rho_{I,K} = R\rho_K^i.$$

Let S^n denote the set of star bodies in \mathbb{R}^n . The subset of S^n that contains the centered star bodies shall be denoted by S_c^n . Two star bodies $K, L \in S^n$ are said to be dilatate (of each other) if $\rho(K, u)/\rho(L, u)$ is independent of $u \in S^{n-1}$.

Let $L_i \in S^n (1 \leq i \leq n)$. The dual mixed volume $\tilde{V}(L_1, \dots, L_n)$ is defined by

$$(2.5) \quad \tilde{V}(L_1, \dots, L_n) = \frac{1}{n} \int_{S^{n-1}} \rho_{L_1}(u) \dots \rho_{L_n}(u)du.$$

We use the notation $\tilde{V}(L_1, i_1; \dots; L_m, i_m)$ for the dual mixed volume in which L_j appears i_j times. The dual quermassintegral $\tilde{W}_i(L)$ of L is given by $\tilde{V}(L, n-i; B_n, i)$. Specially, $\tilde{W}_0(L) = V(L)$.

Let $K, L \in S^n$ and $0 \leq i < n-1$. The dual Aleksandrov-Fenchel inequality [8], p.421; in the form most suitable for our purposes, states that

$$(2.6) \quad \tilde{V}(K, n-i-1; B_n, i; L)^{n-i} \leq \tilde{W}_i(K)^{n-i-1} \tilde{W}_i(L),$$

with equality if and only if K is a dilatate of L .

Let $K \in \mathcal{S}^n$ and $i > 0$. The i -chordal symmetral $\widetilde{\nabla}_i K$ of K is the centered star body defined by [8], p.235

$$(2.7) \quad \rho_{\widetilde{\nabla}_i K}(u) = \left(\frac{\rho_K(u)^i + \rho_K(-u)^i}{2} \right)^{\frac{1}{i}}.$$

Applying Minkowski integral inequality, it follows immediately that for $K \in \mathcal{S}^n$ and $1 \leq i \leq n - 1$

$$(2.8) \quad \widetilde{W}_{n-1-i}(\widetilde{\nabla}_i K) \leq \widetilde{W}_{n-1-i}(K).$$

with equality if and only if K is centered.

From (2.5) and (2.7), it follows that for $K \in \mathcal{S}^n$ and $M \in \mathcal{S}_c^n$

$$(2.9) \quad \widetilde{V}(\widetilde{\nabla}_i K, i; B_n, n - 1 - i; M) = \widetilde{V}(K, i; B_n, n - 1 - i; M).$$

3. A generalization of the Busemann-Petty problem

We consider the following generalization of the Busemann-Petty problem: Consider two origin symmetric star bodies K and L in \mathbb{R}^n . Fix $1 \leq i \leq n - 1$ and suppose that

$$(3.1) \quad I_i K \subseteq I_i L,$$

Does it follow that $\widetilde{W}_{n-1-i}(K) \leq \widetilde{W}_{n-1-i}(L)$?

When $i = n - 1$, condition (3.1) is equivalent to (1.2), so the answer is affirmative if $n \leq 4$ and negative if $n \geq 5$. In this section, we prove that the generalized Busemann-Petty problem has an affirmative answer if K is an intersection body, and that the existence of the body which is not an intersection body leads to a counterexample. We shall use \mathcal{I} to denote the set of intersection bodies.

THEOREM (3.2). *Let $K \in \mathcal{I}$, $L \in \mathcal{S}^n$ and $1 \leq i \leq n - 1$. If*

$$(3.3) \quad I_i K \subseteq I_i L,$$

then

$$(3.4) \quad \widetilde{W}_{n-1-i}(K) \leq \widetilde{W}_{n-1-i}(L),$$

with equality if and only if $K = L$.

Proof. Since $K \in \mathcal{I}$, there exists a star body M , such that $K = IM$, that is

$$(3.5) \quad \rho_K = R\rho_M^{n-1}.$$

By (1.3), (2.3) and (3.5), we get

$$\langle \rho_{I_i K}, \rho_M^{n-1} \rangle = \langle R\rho_K^i, \rho_M^{n-1} \rangle = \langle \rho_K^i, R\rho_M^{n-1} \rangle = \langle \rho_K^i, \rho_K \rangle = \widetilde{W}_{n-1-i}(K).$$

and

$$\langle \rho_{I_i L}, \rho_M^{n-1} \rangle = \widetilde{V}(L, i; B_n, n - 1 - i; K).$$

By condition (3.3), we have

$$\widetilde{W}_{n-1-i}(K) \leq \widetilde{V}(L, i; B_n, n - 1 - i; K).$$

Therefore, by the dual Aleksandrov-Fenchel inequality (2.6) we get (3.4). By the equality condition of (2.6) and $I_i K = I_i L$, we know equality in (3.4) hold if and only if $K = L$. \square

A nature question to ask about theorem (3.2) is whether the class \mathcal{I} can be replaced by a larger subset of S^n . The following result shows that any such large subset would have to be a subset of S_c^n , even if in theorem (3.2) the class S^n were replaced by S_c^n .

THEOREM (3.6). *If $K \in S^n$ is a star body which is not centered and $1 \leq i \leq n - 1$, then there exists a centered star body L , such that*

$$I_i K \subset I_i L,$$

but

$$\widetilde{W}_{n-1-i}(K) > \widetilde{W}_{n-1-i}(L).$$

Proof. From (1.3) and (2.7), we know $\widetilde{\nabla}_i K$ is the unique centered star body such that

$$(3.7) \quad I_i(\widetilde{\nabla}_i K) = I_i K.$$

Since K is not centered and $1 \leq i \leq n - 1$, we know from (2.8) that

$$\widetilde{W}_{n-1-i}(\widetilde{\nabla}_i K) < \widetilde{W}_{n-1-i}(K).$$

Now put

$$L = \varepsilon \widetilde{\nabla}_i K,$$

where $2\varepsilon^n = 1 + \widetilde{W}_{n-1-i}(K)/\widetilde{W}_{n-1-i}(\widetilde{\nabla}_i K)$. Since $\varepsilon > 1$, we have

$$I_i L = \varepsilon^i I_i(\widetilde{\nabla}_i K) = \varepsilon^i I_i K \supset I_i K,$$

and

$$\widetilde{W}_{n-1-i}(L) = \varepsilon^{i+1} \widetilde{W}_{n-1-i}(\widetilde{\nabla}_i K) < \widetilde{W}_{n-1-i}(K).$$

this complete the proof. □

THEOREM (3.8). *Let $L \in S_c^n$ be a star body whose radial function is in $C_e^\infty(S^{n-1})$ and positive. If L is not the intersection body of a star body, then there is a centered star body K such that*

$$(3.9) \quad I_i K \subseteq I_i L,$$

but

$$\widetilde{W}_{n-1-i}(K) > \widetilde{W}_{n-1-i}(L).$$

Proof. Since $\rho_L \in C_e^\infty(S^{n-1})$, there exists (see [14]) an $f \in C_e(S^{n-1})$, such that

$$\rho_L = Rf.$$

Note that f must assume negative values, otherwise L would be the intersection body of star body whose radial function is $f^{1/n-1}$.

We choose a nonconstant function $F \in C_e^\infty(S^{n-1})$, such that

$$(3.10) \quad F(u) \geq 0, \quad \text{when} \quad f(u) < 0,$$

and

$$(3.11) \quad F(u) = 0, \quad \text{when} \quad f(u) \geq 0.$$

Since $F \in C_e^\infty(S^{n-1})$, there exists a function $g \in C_e(S^{n-1})$, such that

$$F = Rg.$$

Define a centered star body K by

$$\rho_K^i = \rho_L^i - \lambda g$$

where $\lambda > 0$ is chosen so that the right-hand side is always positive. Then

$$(3.12) \quad \rho_{I_i K} = R\rho_K^i = R(\rho_L^i - \lambda g) = \rho_{I_i L} - \lambda F.$$

Note that from (3.10), (3.11) and (3.12) we see that $I_i K \neq I_i L$ and

$$(3.13) \quad \rho_{I_i K}(u) \leq \rho_{I_i L}(u), \quad \text{textwhen} \quad (u) < 0,$$

and

$$(3.14) \quad \rho_{I_i K}(u) = \rho_{I_i L}(u), \quad \text{when} \quad f(u) \geq 0.$$

Now using the self-adjointness of R , we obtain

$$\begin{aligned} \widetilde{W}_{n-1-i}(L) - \widetilde{V}(K, i; B_n, n-1-i; L) &= \langle \rho_L^i - \rho_K^i, \rho_L \rangle = \langle \rho_L^i - \rho_K^i, Rf \rangle \\ &= \langle R(\rho_L^i - \rho_K^i), f \rangle = \langle \rho_{I_i L} - \rho_{I_i K}, f \rangle \end{aligned}$$

From (3.13) and (3.14), we have

$$\widetilde{W}_{n-1-i}(L) - \widetilde{V}(K, i; B_n, n-1-i; L) \leq 0$$

A simple application of dual Aleksandrov-Fenchel inequality (2.6) gives us

$$\widetilde{W}_{n-1-i}(K) > \widetilde{W}_{n-1-i}(L).$$

This establishes the statement of the theorem. □

The following theorem give another extension of the Funk section theorem.

THEOREM (3.15). *Let $K \in S_c^n$, $L \in S^n$ and $1 \leq i \leq n-1$. If*

$$I_i K = I_i L,$$

then

$$\widetilde{W}_{n-1-i}(K) \leq \widetilde{W}_{n-1-i}(L),$$

with equality if and only if $K = L$.

To prove the theorem (3.15), we first introduce the following lemma which characterizes the equality of the generalized class of intersection bodies in terms of dual mixed volumes.

LEMMA (3.16). *If $K, L \in S^n$ and $1 \leq i \leq n-1$, then*

$$(3.17) \quad I_i K = I_i L,$$

if and only if

$$(3.18) \quad \widetilde{V}(K, i; B_n, n-1-i; M) = \widetilde{V}(L, i; B_n, n-1-i; M)$$

for all $M \in S_c^n$.

Proof. From (2.9) and (3.7), we see that we may assume that $K, L \in S_c^n$.

Suppose that for all $M \in S_c^n$, (3.18) holds. Let $f \in C_e^+(S^{n-1})$, and define $M \in S_c^n$ by

$$\rho_M = Rf.$$

From (2.1) and (2.5), we have

$$\widetilde{V}(K, i; B_n, n-1-i; M) = \langle \rho_K^i, \rho_M \rangle = \langle \rho_K^i, Rf \rangle,$$

and

$$\tilde{V}(L, i; B_n, n - 1 - i; M) = \langle \rho_L^i, \rho_M \rangle = \langle \rho_L^i, Rf \rangle,$$

Hence, from (2.3), (2.4) and (3.18), we have

$$\langle \rho_{I_i K}, f \rangle = \langle \rho_{I_i L}, f \rangle.$$

Thus, for all $f \in C_e^+(S^{n-1})$

$$\langle \rho_{I_i K} - \rho_{I_i L}, f \rangle = 0.$$

But this must hold for all $f \in C_e(S^{n-1})$, since we can write an arbitrary function in $C_e(S^{n-1})$ as the difference of two functions in $C_e^+(S^{n-1})$. If we take $\rho_{I_i K} - \rho_{I_i L}$ for f , we get $|\rho_{I_i K} - \rho_{I_i L}|_2 = 0$, and hence $I_i K = I_i L$.

Now suppose (3.17) holds and $M \in S_c^n$. Suppose M is such that $\rho_M \in R(C_e(S^{n-1}))$ and hence there exists an $f \in C_e(S^{n-1})$, such that

$$\rho_M = Rf.$$

From (2.5), we have

$$\tilde{V}(K, i; B_n, n - 1 - i; M) = \langle \rho_K^i, \rho_M \rangle = \langle \rho_K^i, Rf \rangle,$$

and

$$\tilde{V}(L, i; B_n, n - 1 - i; M) = \langle \rho_L^i, \rho_M \rangle = \langle \rho_L^i, Rf \rangle,$$

If we use (2.3) and (2.4), we see that $I_i K = I_i L$ implies that (3.18) must hold for all $M \in S_c^n$ such that $\rho_M \in R(C_e(S^{n-1}))$. Since $R(C_e(S^{n-1}))$ is dense in $C_e(S^{n-1})$, and dual mixed volumes are continuous, it follows that (3.18) must hold for all $M \in S_c^n$. □

The proof of Theorem 3.5. Since $K \in S_c^n$, let $M = K$ in lemma (3.16), we have

$$\tilde{W}_{n-1-i}(K) = \tilde{V}(L, i; B_n, n - 1 - i; K)$$

By the dual Aleksandrov-Fenchel inequality (2.6), we have

$$\tilde{W}_{n-1-i}(K) \leq \tilde{W}_{n-1-i}(L),$$

The equality condition of (2.6) and $I_i K = I_i L$ yield the equality in theorem (3.15) if and only if $K = L$. □

Acknowledgment

The authors are most grateful to the referee for his valuable suggestions.

Received December 21, 2007

Final version received May 15, 2009

ZHAO LINGZHI
 DEPARTMENT OF MATHEMATICS
 NANJING XIAOZHUANG UNIVERSITY
 NANJING 211171
 P. R. CHINA
 lzhzhao@163.com

SHEN YAJUN
 DEPARTMENT OF APPLIED MATHEMATICS
 ZHEJIANG FORESTRY UNIVERSITY

HANGZHOU, 311300
P. R. CHINA
syjun168@163.com

REFERENCES

- [1] K. M. BALL, Some remarks on the geometry of convex sets, In Geometric Aspects of Functional Analysis, ed. by J. Lindenstrauss and V. D. Milman, Lecture Notes in Mathematics **1317**. Springer, Heidelberg, 1989. 224–331.
- [2] H. BUSEMANN AND C. M. PETTY, *Problems on convex bodies*, Math. Scand. **4** (1956), 88–94.
- [3] J. BOURGAIN, *On the Busemann-Petty problem for perturbations of the ball*, Geom. Funct. Anal. **1** (1991), 1–13.
- [4] P. FUNK, *Über Flächen mit lauter geschlossenen geodätischen Linien*, Math. Ann. **74** (1913), 278–300.
- [5] R. J. GARDNER, *On the Busemann-Petty problem concerning central sections of centrally symmetric convex bodies*, Bull. Amer. Math. Soc. **30** (1994), 222–226.
- [6] R. J. GARDNER, *Intersection bodies and the Busemann-Petty problem*, Trans. Amer. Math. Soc. **342** (1994), 435–445.
- [7] R. J. GARDNER, *A positive answer to the Busemann-Petty problem in three dimensions*, Ann. of Math. (2) **140** (1994), 435–447.
- [8] R. J. GARDNER, *Geometric Tomography*, second edition, Cambridge University Press, New York, 2006.
- [9] A. A. GIANNOPOULOS, *A note on a problem of H. Busemann and C. M. Petty concerning sections of symmetric convex bodies*, Mathematika, **37** (1990), 239–244.
- [10] D. G. LARMAN AND C. A. ROGERS, *The existence of a centrally symmetric convex body with central sections that are unexpectedly small*, Mathematika, **22** (1975), 164–175.
- [11] E. LUTWAK, *Intersection bodies and dual mixed volumes*, Adv. Math. **71** (1988), 232–261.
- [12] S. LV AND G. LENG, *Cross i -sections of star bodies and dual mixed volumes*, Proc. Amer. Math. Soc. **135** (2007), 3367–3373.
- [13] M. PAPADIMITRAKIS, *On the Busemann-Petty problem about convex, centrally symmetric bodies in \mathbb{R}^n* , Mathematika, **39** (1992), 258–266.
- [14] R. S. STRICHARTZ, *L^p estimates for Radon transforms in Euclidean and non-Euclidean spaces*, Duke Math. J. **48** (1981), 699–727.
- [15] G. Y. ZHANG, *Centered bodies and dual mixed volumes*, Tran. Amer. Math. **345** (1994), 777–801.
- [16] G. Y. ZHANG, *A positive solution to the Busemann-Petty problem in \mathbb{R}^4* , Annals of Math. **149** (1999), 535–543.

A NOTE ON NEARNESS SPREADS IN FRAMES

HLENGANI J. SIWEYA AND MARUTHANYANE J. MAKGERU

ABSTRACT. Mathematical structures called *spreads* are extended to nearness frames and a nearness spread completion associated with these structures is constructed. There is a *relative notion of uniform local connectedness* which enjoys notable properties many of which play an important part in this construction. In fact, it is also shown that if $h: (M, \mathfrak{N}M) \rightarrow (L, \mathfrak{N}L)$ is a dense surjection between nearness frames, then L is uniformly locally connected iff L is uniformly locally connected relative to h .

1. Introduction

In an effort to keep this note short as far as is possible, we assume familiarity with nearness and uniform frames. However, those that are uncomfortable are referred to [1], [3], [6]. A standard reference for general knowledge of frames is [7].

A frame is a complete lattice L in which the following generalized distributive law holds:

$$x \wedge (\bigvee M) = \bigvee \{x \wedge y \mid y \in M\},$$

for each $x \in L$ and $M \subset L$; and a *frame homomorphism* is a map $h: M \rightarrow L$ which preserves finitary meets (including the *top element* e and arbitrary joins (including the *bottom element* 0). A frame homomorphism is *dense* if whenever $h(x) = 0$.

With reference to connectedness, we say: $0 \neq x$ in a frame L *connected* if whenever $x = a \vee b$ with $a \wedge b = 0$ then either $a = 0$ or $b = 0$. The frame L is *connected* whenever its top e is connected, and L is *locally connected* if each $x \in L$ is a join of connected $y \in L$ with $y \leq x$. A *component* of $x \in L$ is a maximally connected $y \leq x$ in L . See Baboolal and Banaschewski [2] and Chen [5].

A *cover* of a frame L is a subset A of L for which $\bigvee A = e$. The collection of all covers of L is denoted $\text{cov}(L)$. Given $U, V \in \text{cov}(L)$ the cover U *refines* the cover V (written $U \leq V$) if for each $u \in U$ there exists $v \in V$ with $u \leq v$. For a $U \in \text{cov}(L)$, the *x-star* of an element $x \in L$ relative to U is the set $Ux = \bigvee \{y \in U \mid x \wedge y \neq 0\}$. A cover U *star refines* another cover $V \in \text{cov}(L)$ (written $U* \leq V$) if $UU \leq V$ where $UU = \{Ux \mid x \in U\}$.

If $x, y \in L$ and $\mathfrak{N} \subseteq \text{cov}(L)$, we say that x is \mathfrak{N} -*uniformly below* y (written $x \triangleleft_{\mathfrak{N}} y$) if $Ux \leq y$ for some $U \in \mathfrak{N}$. A filter on $\text{cov}(L)$ is called a *nearness* on L if

2000 *Mathematics Subject Classification*: 54D15, 54D20, 54E15.

Keywords and phrases: nearness frame spread, uniformly locally connected (relative to), locally connected frame.

it is an *admissible system of covers* in the sense that each $x \in L$ is expressible in the form

$$x = \bigvee \{y \in L \mid y \triangleleft_{\mathfrak{N}} x\}$$

Together with a nearness \mathfrak{N} on the frame L the pair (L, \mathfrak{N}) is a *nearness frame*. If in addition the nearness \mathfrak{N} satisfies the condition that: for each $U \in \mathfrak{N}$ there is a $V \in \mathfrak{N}$ satisfying $U^* \leq V$ then the pair (L, \mathfrak{N}) is a *uniform frame*.

For an element $x \in L$ we define its *pseudo-complement* x^* by

$$x^* = \bigvee \{y \in L \mid x \wedge y = 0\};$$

x is said to be *rather below* y (and we write $x \prec y$) if there exists a $z \in L$ such that $x \wedge z = 0$ and $y \vee z = e$ or, equivalently, if $x^* \vee y = e$. The frame L is *regular* if each $x \in L$ can be written as $x = \bigvee \{y \in L \mid y \prec x\}$. In connection with nearness, it is known that a frame has a nearness iff it is regular (Banaschewski and Pultr [3]).

A nearness frame $(L, \mathfrak{N}L)$ is *uniformly locally connected* if for each $A \in \mathfrak{N}L$ there exists a $B \in \mathfrak{N}L$ such that $B \leq A$ with each $b \in B$ connected (Baboolal and Banaschewski [4]). For a surjective homomorphism $h : (L, \mathfrak{N}L) \rightarrow (M, \mathfrak{N}M)$ between nearness frames, we say M is *uniformly locally connected relative to h* if there exists a nearness basis \mathfrak{B} for $\mathfrak{N}L$ for which $h[B]$ is connected for each $B \in \mathfrak{B}$.

PROPOSITION (1.1). *For any dense surjection $h : (M, \mathfrak{N}M) \rightarrow (L, \mathfrak{N}L)$ between nearness frames, the nearness frame L is uniformly locally connected iff L is uniformly locally connected relative to h .*

Proof. See [4], Proposition 2.6. □

2. Nearness Spreads on frames

Recall [8] that a *spread* is a frame homomorphism $h : M \rightarrow L$ between locally connected frames for which $x \in L$ is a component of $h(u)$ for some $u \in M$. (In the rest of the article we will write $x \leq_c h(u)$ to mean “ x is a component of $h(u)$ ”. In this article, we propose to work with a spread (M, h, L) between locally connected regular frames; M carries the fine nearness $Cov(M)$ consisting of all covers of M . For each $A \in Cov(M)$, set

$$C_A = \{x \in L \mid x \leq_c h(a), \text{ for some } a \in A\}.$$

Nearness spreads themselves were introduced into nearness spaces by Siweya [9]. We now generalize such spreads into the setting of nearness frames as follows. In fact, a nearness spread completion is constructed—and it comes with the uniform spread completion of Baboolal and Siweya [4] as a special case.

PROPOSITION (2.1). *The set $\{C_A \mid A \in Cov(M)\} =: \mathfrak{B}^h L$ form a basis for a nearness $\mathfrak{N}^h L$ on L relative to which L is uniformly locally connected, i.e. we have the following:*

- (i) $A \in Cov(M) \Rightarrow \bigvee C_A = e$;
- (ii) $C_{A_1}, C_{A_2} \in \mathfrak{B}^h L \Rightarrow \exists A_3 \in Cov(M), C_{A_3} \leq C_{A_1} \wedge C_{A_2}$.

Proof. Each $C_A \in Cov(L)$ since

$$\begin{aligned} e &= \bigvee h[A] \\ &= \bigvee_{a \in A} h(a) \\ &= \bigvee_{a \in A} (\bigvee w \quad (w \leq_c h(a))) \\ &= \bigvee C_A. \end{aligned}$$

Given C_A, C_B of the above form, we set $G = A \wedge B$. We will show that $C_G \leq C_A$ and $C_G \leq C_B$: If $x \in C_G$ then $x \leq_c h(u)$ for some $u = a \wedge b \in G$. Therefore $x \leq_c h(u) \leq h(a)$ and $x \leq_c h(u) \leq h(b)$. Thus for some $s, t \in L$ we have $x \leq s \leq_c h(a)$ and $x \leq t \leq_c h(b)$. In addition, for any $h[A]x \leq y$ in L we find that $C_A x \leq y$: For, if $z \in C_A$ with $z \wedge x \neq 0$ then $z \leq_c h(u_z)$ for some $u_z \in A$. Also, $h(u_z) \wedge x \neq 0$ implies that $h(u_z) \leq h[A]x \leq y$ so that $z \leq y$ and $C_A x \leq y$. Thus $y = \bigvee \{x \in L \mid C_A x \leq y, \text{ for some } A \in Cov(M)\}$. \square

We will denote the nearness structure so formed (called a *spread nearness*) by $\mathfrak{N}^h L$, and h will be called a *nearness spread (morphism)* on M .

Our definition of completeness of a nearness spread is inspired by that of a complete nearness frame [3]. In order to construct a nearness spread completion, we need

Definition (2.2). A nearness spread $f : (M, \mathfrak{N}M) \rightarrow (L, \mathfrak{N}^f L)$ is said to be *complete* if, whenever $g : (M, \mathfrak{N}M) \rightarrow (N, \mathfrak{N}^g N)$ is a nearness spread and $h : N \rightarrow L$ is a dense surjection with L uniformly locally connected relative to h such that $f = h \circ g$, then h is an isomorphism. A *nearness spread completion* of a nearness spread $f : M \rightarrow L$ is a complete nearness spread $g : M \rightarrow N$ with a dense surjection $h : N \rightarrow L$ for which L is uniformly locally connected relative to h such that $f = h \circ g$ holds.

The nearness spread completion discussed herein assumes familiarity with Banaschewski-Pultr nearness frame completion as well as the associated notation used in [3]. Some of these details are as follows: $\mathfrak{D}L$ denotes the frame of all non-empty downsets of L , that is, consisting of all $U \subset L$ such that $0 \in U, x \leq y, y \in U \Rightarrow x \in U$, partially ordered by inclusion, so that meet is intersection and join union. Then, let $\mathfrak{R}L$ denote the closure system in $\mathfrak{D}L$ such that $U \in \mathfrak{R}L$ holds iff $l_0 : \mathfrak{D}L \rightarrow \mathfrak{D}L$ defined by setting $l_0(U) = \{a \in L \mid \{x \in L \mid x \triangleleft a\} \subset U\} \cup \dots \cup \{a \in L \mid \{a \wedge X \mid X \in C\} \subset U \text{ for some } C \in \mathfrak{N}L\}$. (Here “ \triangleleft ” denotes the “strong” inclusion relative to $\mathfrak{N}L$.) Then l_0 satisfies:

- (i) $U \subset l_0(U)$;
- (ii) $U_1 \subset U_2 \Rightarrow l_0(U_1) \subset l_0(U_2)$;
- (iii) $U_1, U_2 \in \mathfrak{D}L \Rightarrow l_0(U_1) \cap U_2 \subset l_0(U_1 \cap U_2)$.

It follows then that the closure operator l on $\mathfrak{D}L$ determined by $\mathfrak{R}L$ preserves binary intersections, so that $\mathfrak{R}L$ is a frame.

Furthermore, the frame homomorphism $\bigvee : \mathfrak{D}L \rightarrow L$ given by taking join factors through the map $l_L : \mathfrak{D}L \rightarrow \mathfrak{R}L$. The map $\mathfrak{R}L \rightarrow L$ determined by the factorization of $\bigvee : \mathfrak{D}L \rightarrow L$ through $l : \mathfrak{D}L \rightarrow \mathfrak{R}L$ is the join map δ_L restricted

to $\mathfrak{R}L$. Thus, $\delta_L: \mathfrak{R}L \rightarrow L$ is a frame homomorphism. Since $l(\downarrow a)_L := (\downarrow a)_L$ for all $a \in L$, where $(\downarrow a)_L := \{x \in L \mid x \leq a\}$, it is obvious that the right adjoint $r_L: L \rightarrow \mathfrak{R}L$ to the join map $\mathfrak{R}L \rightarrow L$ is given by $r_L(a) := (\downarrow a)_L$. We shall use subscripts L to emphasize the closure operator $l_L: \mathfrak{O}L \rightarrow \mathfrak{R}L$, the join homomorphism $\delta_L: \mathfrak{R}L \rightarrow L$ and its right adjoint $r_L: L \rightarrow \mathfrak{R}L$ corresponding to the nearness frame L . In what follows then, unless specified otherwise, $h: (\mathfrak{R}M) \rightarrow (L, \mathfrak{R}^h L)$ is a nearness spread.

Now consider, for each $A \in \mathfrak{R}M$, the collection (in $\mathfrak{R}L$)

$$C^L[A] = \{(l \downarrow)_L(x) \in \mathfrak{R}L \mid (l \downarrow)_L(x) \leq \mathfrak{R}h(l \downarrow)_M(a), \text{ where } x \leq_c h(a)\},$$

for some $a \in A$.

PROPOSITION (2.3). *The collection*

$$\{C^L[A] \mid A \in \text{Cov}(M)\}$$

is a basis for a nearness structure relative to which $\mathfrak{R}L$ is uniformly locally connected.

Proof. (1) Since $A \in \text{Cov}(M)$ we have $\bigcup C^L[A] = e$.

(2) Given $C^L[A]$, $C^L[B]$, consider $C^L[D]$ where $D = A \wedge B$. We claim that $C^L[D] \leq C^L[A]$ and $C^L[D] \leq C^L[B]$. For, if $(l \downarrow)_L(x) \in C^L[D]$, it holds that $x \leq_c h(a)$ for some $A \in \text{Cov}(M)$ and $a = m \wedge n$ with $m \in A, n \in B$ from which it is not hard to prove that $(l \downarrow)_L(x) \leq \mathfrak{R}h(l \downarrow)_M(a)$ so that $(l \downarrow)_L(x) \in C^L[A]$ and $(l \downarrow)_L(x) \in C^L[B]$, which takes care of our claim.

(3) Given $y \in L$, we have

$$y = \bigvee \{x \in L \mid h[A]x \leq y, \text{ for some } A \in \text{Cov}(M)\}.$$

We claim that $C^L[A]x \leq y$: For, if $(l \downarrow)_L(z) \in C^L[A]$ with $(l \downarrow)_L(z) \wedge (l \downarrow)_L(x) \neq 0$ we can show that $z \leq_c h(a_z) \leq y$ because $h[A]x \leq y$ for some $a_z \in A$ and so $C^L[A]x \leq y$. □

COROLLARY (2.4). *The nearness map $\mathfrak{R}h: \mathfrak{R}M \rightarrow \mathfrak{R}L$ making the following rectangle commutative is a nearness spread:*

$$\begin{array}{ccc} \mathfrak{R}M & \xrightarrow{\mathfrak{R}h} & \mathfrak{R}L \\ \delta_M \downarrow & & \downarrow \delta_L \\ M & \xrightarrow{h} & L \end{array}$$

□

Remark (2.5). We note that a nearness frame L is complete iff whenever $e \in U, U \in \mathfrak{R}L$ then $\bigvee U = e$ holds. Moreover, any fine nearness frame is complete, hence the nearness frame $(L, \text{Cov}(L))$ is complete.

Returning to a nearness spread completion, recall that a fine nearness frame is complete [3], so the fine nearness frame $(L, \text{Cov}(L))$ is complete. Accordingly, the dense surjection $\delta_L: \mathfrak{R}L \rightarrow L$ is an isomorphism. Here is our main result.

THEOREM (2.6). *The triple $(M, \mathfrak{R}h \circ \delta_M^{-1}, L)$ together with the dense surjection $\delta_L: \mathfrak{R}L \rightarrow L$ is a nearness spread completion of the nearness spread $h: M \rightarrow L$ (with $g = \mathfrak{R}h \circ \delta_M^{-1}$ in the commutative triangle):*

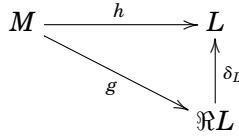

Proof. Also, the uniqueness of $\mathfrak{R}L$ implies that of $\mathfrak{R}h \circ \delta_M^{-1}$.

Now, we have:

1) Since L is uniformly locally connected (because h is a nearness spread) and since $\delta_L: \mathfrak{R}L \rightarrow L$ is a dense surjection, it follows that L is locally connected relative to δ_L (Proposition (1.1)).

2) For commutativity, we find that

$$\begin{aligned}
 \delta_L \circ (\mathfrak{R}h \circ \delta_M^{-1}) &= (\delta_L \circ \mathfrak{R}h) \circ \delta_M^{-1} \\
 &= (h \circ \delta_M) \circ \delta_M^{-1} \\
 &= h \circ (\delta_M \circ \delta_M^{-1}) \\
 &= h.
 \end{aligned}$$

3) We now show that $\mathfrak{R}h \circ \delta_M^{-1}$ is a complete nearness spread: let (M, k, N) be a nearness spread and let $f: N \rightarrow \mathfrak{R}L$ be a dense surjection where $\mathfrak{R}L$ is uniformly locally connected relative to f such that $g = f \circ k$ (with $g = \mathfrak{R}h \circ \delta_M^{-1}$):

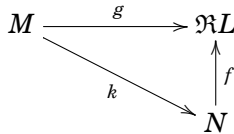

Then the dense surjection f is an isomorphism since $\mathfrak{R}L$ is completion, hence $\mathfrak{R}h \circ \delta_M^{-1}$ is complete.

4) It remains to show that this completion $\mathfrak{R}h \circ \delta_M^{-1}$ is unique up to equivalence. To this end, suppose that (r, P, s) were another nearness spread completion of (M, h, L) where P is a nearness completion of M . By uniqueness of $\mathfrak{R}L$ (being the nearness completion of L), there is an isomorphism $k: \mathfrak{R}L \rightarrow P$ such that $s \circ k = \delta_L$ (with $t = \mathfrak{R}h \circ \delta_M^{-1}$):

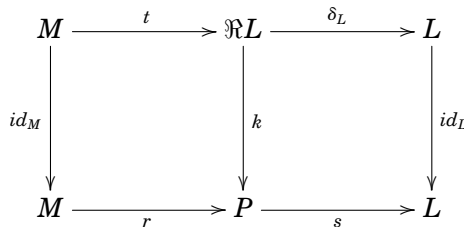

The following calculations follow:

$$\begin{aligned}
 s \circ (k \circ \mathfrak{R}h \circ \delta_M^{-1}) &= (s \circ k) \circ (\mathfrak{R}h \circ \delta_M^{-1}) \\
 &= \delta_L \circ (\mathfrak{R}h \circ \delta_M^{-1}) \\
 &= h \\
 &= s \circ r.
 \end{aligned}$$

Since s is a monomorphism, we have

$$k \circ (\mathfrak{R}h \circ \delta_M^{-1}) = r$$

so that $(\mathfrak{R}h \circ \delta_M^{-1}, \mathfrak{R}L, \gamma_L)$ is equivalent to (r, P, s) . \square

Acknowledgment

We are indebted to the unknown referee for comments and a suggestion that improved this version of the paper.

Received May 28, 2008

Final version received January 30, 2009

DEPARTMENT OF MATHEMATICS AND APPLIED MATHEMATICS
 UNIVERSITY OF LIMPOPO
 PRIVATE BAG X1106
 SOVENGA 0727
 SOUTH AFRICA
 siweyah@ul.ac.za

REFERENCES

- [1] D. BABOOLAL, *Local connectedness made uniform*, Appl. Categ. Structures **8** (1-2), (2000), 377–390.
- [2] D. BABOOLAL AND B. BANASCHEWSKI, *Compactification and local connectedness of frames*, J. Pure Appl. Algebra **70** (1991), 3–16.
- [3] B. BANASCHEWSKI AND A. PULTR, *Cauchy points of uniform and nearness frames*, Quaest. Math. **19** (1996), 101–127.
- [4] D. BABOOLAL AND H. J. SIWEYA, *Uniform spread completion for frames*, Sci. Math. Jpn. **56** (2) (2002), 401–412.
- [5] X. CHEN, *On local connectedness of frames*, Pure Appl. Algebra **79** (1992), 35–43.
- [6] T. A. DUBE, *Structures in frames*, PhD Thesis (University of Durban-Westville), 1993.
- [7] P. T. JOHNSTONE, *Stone Spaces*, Cambridge Studies in Advanced Mathematics, 3. Cambridge University Press, 1982.
- [8] H. J. SIWEYA, *Spreads in locales and uniform locales*, PhD Thesis (University of Durban-Westville), 2000.
- [9] H. J. SIWEYA, *Fox's spreads on Nearness Spaces*, Bol. Soc. Mat. Mexicana (3) **13**, (2007), 187–194.

EXPONENT AND CELL STRUCTURE OF THE v_1 -PERIODIC SPECTRA ASSOCIATED TO EXCEPTIONAL LIE GROUPS

XIAOXUE LI

ABSTRACT. Let ΦX be the v_1 -periodic spectrum associated to a topological space X , which satisfies $\pi_*(\Phi X) = v_1^{-1}\pi_*(X; p)$. Bousfield proved that the p -exponent of the spectrum ΦX is the same as the p -exponent of the group $K^1(\Phi X) = PK^1(X)/\psi^p$. We calculate the summand decomposition of $K^1(\Phi X)$ and get the p -exponent as the largest summand. We accomplish this for all exceptional Lie groups X and all odd primes p and compare them with the known p -exponent of the homotopy group $\pi_*(\Phi X)$. We found that most of the time they differ by 1 or 2.

Our second result is to interpret the way the spectrum ΦX is built. The spectrum ΦX can be built up from various ΦS^{2i+1} by fibrations. For all exceptional Lie groups at all odd primes p , we obtain a nice picture of how the ΦS^{2i+1} s are attached together to build ΦX .

1. Introduction

The v_1 -periodic spectrum ΦX , introduced by Bousfield, is a K/p_* -local spectrum associated to a topological space X , satisfying, for the spaces studied here, $\pi_*(\Phi X) \approx v_1^{-1}\pi_*(X; p)$, the v_1 -periodic homotopy groups ([6]). In this paper we analyze certain properties of ΦX when X is an exceptional Lie group and p is an odd prime.

The first property that we analyze is the p -exponent of the spectrum ΦX . In [6], 9.5; Bousfield conjectured the value of the p -exponent of $\Phi SU(n)$, and M. Fisher proved this conjecture [8]. We use a method, different from Fisher's, involving an algorithm on the Adams operations, which allows us to compute the p -exponent of ΦX for all exceptional Lie groups X at all odd primes p .

The second property we analyze is the cell structure of ΦX . We prove that a spectrum ΦX can be built up by fibrations from ΦS^{2i+1} s. How these ΦS^{2i+1} cells are attached together is quite interesting. We determine the attaching maps between the ΦS^{2i+1} s for all exceptional Lie groups X at all odd primes p by studying the Adams operations in the K-theory of ΦX and the v_1 -periodic homotopy groups in which the attaching maps lie.

This paper is divided into four sections. Our main theorems, (1.1), (1.2), and (1.3) are contained in the introductory first section. In Section 2 we begin by reviewing some results from Bousfield's paper [6]. We then calculate the p -exponent of ΦX for the pairs (X, p) with X an exceptional Lie group and p an odd prime. In Section 3 we first prove in Theorem 3.4 that the spectrum ΦX can be built up from various ΦS^{2i+1} . In building ΦX , the key is to find the

2000 *Mathematics Subject Classification*: Primary 55P42, secondary 55S25.

Keywords and phrases: exponents, K/p_* -local spectra, fibrations, Adams operations, exceptional Lie groups.

attaching maps between the cells. These attaching maps are detected by the Adams operations and $v_1^{-1}\pi_*(X)$. We first obtain the attaching maps for ΦX when X is torsion-free. These are simpler than the torsion cases because the exceptional Lie groups that are torsion-free decompose as products of spaces of the form $B(2n_1 + 1, \dots, 2n_r + 1)$ and odd dimensional spheres when localized at p . The torsion exceptional Lie groups consist of $(F_4, 3)$, $(E_6, 3)$, $(E_7, 3)$, $(E_8, 5)$, and $(E_8, 3)$. The cell structure of the associated spectra are carried out in Section 4. Each case is different and requires different techniques. Throughout this paper, p is an odd prime, and $q = 2(p - 1)$.

We state our main results in Theorem (1.1), (1.2), and (1.3).

The p -exponent of a spectrum E is the smallest e such that p^e times the identity map $E \rightarrow E$ is trivial. We denote it by $\text{exp}_p(E)$. We calculate the p -exponents of the v_1 -periodic spectra ΦX of exceptional Lie groups X for each odd prime p , and compare them with the known p -exponents of the homotopy groups $\pi_*(\Phi X)$. We also compute the whole group $K^1(\Phi X)$. Throughout this paper, the K -theory groups always have p -adic coefficients $\hat{\mathbb{Z}}_p$.

In Theorem (1.1), the third column, $\text{exp}_p(\Phi X)$, is the principal focus of this part of our work.

X	p	$\text{exp}_p(\Phi X)$	$\text{exp}_p(\pi_*(\Phi X))$	$K^1(\Phi X)$
G_2	3	6	6	6
	5	6	6	6
	> 5	5	5	1,5
F_4	3	12	12	4,8,12
	5	12	11	6,6,12
	7	12	11	8,4,12
	11	12	12	12,5,7
	> 11	11	11	1,5,7,11
E_6	3	12	12	3,4,8,9,12
	5	12	11	3,9,6,6,12
	7	12	11	8,4,12,4,8
	11	12	12	12,5,7,4,8
	> 11	11	11	1,4,5,7,8,11
E_7	3	22	19	4,9,12,16,22
	5	20	18	3,6,8,12,14,20
	7	19	17	3,7,9,11,14,19
	11	18	17	12,6,18,5,9,13
	13	18	17	14,4,18,7,9,11
	17	18	18	18,5,7,9,11,13
	> 17	17	17	1,5,7,9,11,13,17
E_8	3	39	30	3,11,16,23,28,39
	5	31	30	4,10,12,17,20,26,31
	7	32	29	6,18,12,24,18,30
	11	30	29	12,6,18,12,24,18,30
	13	30	29	14,6,20,10,24,16,30
	17	30	29	18,6,24,12,30,11,19
	19	30	29	20,10,30,7,13,17,23
	23	30	29	24,6,30,11,13,17,19
	29	30	30	30,7,11,13,17,19,23
	> 29	29	29	1,7,11,13,17,19,23,29

Table 1. Exponents of ΦX

THEOREM (1.1). *For the exceptional Lie groups X and odd primes p , the exponents of ΦX and of its homotopy groups are as listed in Table (1), which also includes the p -exponents of the summands of $K^1(\Phi X)$.*

The homotopy p -exponent of ΦX , which is the least power of p that annihilates the p -torsion in $\pi_*(\Phi X)$, is listed in the fourth column in this table. These homotopy exponents of ΦX are read off from Davis' papers ([7],[2],[3],[4]) and are included for comparison. The other main result is the cell structure of ΦX . Our results are shown in Theorem (1.2) for torsion free X and in Theorem (1.3) for torsion X .

THEOREM (1.2). *Let X be an exceptional Lie group that is torsion free. The spectrum ΦX can be built by fibrations from ΦS^{2i+1} according to the scheme in Table (2).*

X	p	Cell Structure of ΦX					
G_2	3	α_2					
	5						
F_4	5						
	7						
	11						
E_6	5						
	7						
	11						
E_7	5	α_2					
	7	α_2					
	11						
	13						
	17						
E_8	7	α_2					
	11						
	13						
	17						
	19						
	23						
	29						

Table 2. Cell Structure - Torsion free cases

In the above table and later in this paper, a straight line connecting two cells denotes an attaching map α_1 . The circled number notation is explained in the paragraph surrounding (3.10).

THEOREM (1.3). *Let X be a torsion exceptional Lie group. The spectrum ΦX can be built by fibrations from ΦS^{2i+1} according to the scheme in Table 3.*

X	p	Cell Structure of ΦX
F_4	3	
E_6	3	
E_7	3	
E_8	3	
	5	

Table 3. Cell Structure - torsion cases

2. The p -exponent of ΦX

In this section we prove Theorem (1.1). That is, we calculate the p -exponent of the v_1 -periodic spectrum ΦX for all the pairs (X, p) with X an exceptional Lie group and p an odd prime. We begin with the definition of the functor Φ and some mod p K -theory localization results due to Bousfield.

In [6], Bousfield introduced a functor from the homotopy category of pointed CW-complexes to the category of K/p_* -local spectra.

Definition (2.1) ([6], 7.2). There is a functor $\Phi: Ho_* \rightarrow \mathcal{S}$, where Ho_* is the homotopy category of pointed CW-complexes and \mathcal{S} is the category of K/p_* -local spectra, such that:

1. For a space $Y \in Ho_*$ and finite p -torsion spectrum $W \in \mathcal{S}$, there is a natural isomorphism $v_1^{-1}\pi_*(Y; W) \cong [W, \Phi Y]$;
2. ΦY is K/p_* -local for each $Y \in Ho_*$;
3. For a spectrum E , there is a natural equivalence $\Phi(\Omega^\infty E) \cong E_{K/p}$;
4. Φ preserves homotopy fiber sequences.

Definition (2.2) ([6], 2.6). A finite stable p -adic Adams module is a finite abelian p -group G with endomorphisms $\psi^k: G \rightarrow G$ for $k \in \mathbb{Z} - p\mathbb{Z}$ such that

1. $\psi^1 = Id$ and $\psi^j \psi^k = \psi^{jk}$ for all $j, k \in \mathbb{Z} - p\mathbb{Z}$;

2. there exists an integer $n \geq 1$ such that $\psi^k = \psi^{k+p^n}j$ on G for all $k \in \mathbb{Z} - p\mathbb{Z}$ and $j \in \mathbb{Z}$.

Here \mathbb{A} denote the abelian category of stable p -adic Adams modules.

For a stable p -adic Adams module M , there exists a homotopically unique K/p_* -local spectrum $\mathcal{M}(M, 1)$ with $K^1(\mathcal{M}(M, 1); \mathbb{Z}_p) \cong M$ and $K^0(\mathcal{M}(M, 1); \mathbb{Z}_p) \cong 0$. Bousfield also proved

THEOREM (2.3) ([6], 8.1). *If X is a connected K/p_* -durable space (e.g. a connected H -space) with $K^*(X; \hat{\mathbb{Z}}_p) \cong \hat{\Lambda}(M)$ for a regular torsion-free p -adic Adams module $M \subset K^1(X; \hat{\mathbb{Z}}_p)$, then ΦX is the homotopy fiber of the map $\mathcal{M}(\psi^p, 1): \mathcal{M}(M, 1) \rightarrow \mathcal{M}(M, 1)$. In particular, if $\psi^p: M \rightarrow M$ is monic, then $\Phi X \cong \mathcal{M}(M/\psi^p, 1)$.*

If X is a compact Lie group, Hodgkin ([9]) proved that

$$K^*(X) = \Lambda[\beta(\rho_1), \dots, \beta(\rho_l)].$$

This ensures that a compact Lie group X satisfies the hypothesis in Theorem (2.3). Therefore ΦX is a $K\hat{\mathbb{Z}}_p$ -Moore Spectrum $\mathcal{M}(M/\psi^p, 1)$, where $M = PK^1(X, \hat{\mathbb{Z}}_p) \subset K^1(X; \hat{\mathbb{Z}}_p)$. i.e, $\Phi X \cong \mathcal{M}(PK^1(X)/\psi^p, 1)$. Here P denotes the primitives. This equivalence suggests an algebraic way to obtain the p -exponent of the spectrum ΦX by finding the p -exponent of the stable Adams module in $\mathcal{M}(PK^1(X)/\psi^p, 1)$.

THEOREM (2.4) ([6], 8.2). *For a stable p -adic Adams module G and a spectrum E with $K^0(E; \hat{\mathbb{Z}}_p) = 0$, there is a splittable short exact sequence*

$$0 \rightarrow \text{Ext}_{\mathcal{A}}^2(G, K^1(\Sigma^2 E; \hat{\mathbb{Z}}_p)) \rightarrow [E, \mathcal{M}(G, 1)] \rightarrow \text{Hom}_{\mathcal{A}}(G, K^1(E, \hat{\mathbb{Z}}_p)) \rightarrow 0$$

and an isomorphism

$$(2.5) \quad [\Sigma E, \mathcal{M}(G, 1)] \cong \text{Ext}_{\mathcal{A}}^1(G, K^1(\Sigma^2 E; \hat{\mathbb{Z}}_p)).$$

This theorem implies that there is a surjective map:

$$[\Phi X, \Phi X] \longrightarrow \text{Hom}_{\mathcal{A}}(PK^1(X)/\psi^p, PK^1(X)/\psi^p).$$

Moreover, Bousfield observes on [6], p.1245; that this is an isomorphism as long as $PK^1(X)/\psi^p$ is torsion-free. If $p^e(PK^1(X)/\psi^p) = 0$ for some $e \geq 1$, then $p^e 1_{\Phi X} \cong 0$. This implies that the p -exponent of the spectrum ΦX is the same as the p -exponent of $PK^1(X)/\psi^p = K^1(\Phi X)$, which is a finite abelian p -group in our case. So we calculate the summand decomposition of $PK^1(X)/\psi^p = \bigoplus \mathbb{Z}/p^{e_i}$ and get the p -exponent of ΦX as the largest exponent.

We now proceed to calculate $\text{exp}_p(\Phi X)$ for all X that are exceptional Lie groups and all odd primes p . We consider first the quasi p -regular cases.

Calculation of $\text{exp}_p(\Phi X)$ for quasi p -regular cases.

Definition (2.6). Let $B(2n + 1, 2n + 1 + q)$ be the S^{2n+1} -bundle over $S^{2n+2p-1}$ such that

$$H^*(B(2n + 1, 2n + 1 + q); \mathbb{Z}_p) \cong \Lambda(x_{2n+1}, P^1 x_{2n+1}).$$

The Lie group G is called quasi p -regular iff there exists a map from a product of sphere-bundles over spheres of type $B(2n + 1, 2n + 1 + q)$ and spheres into G such that it induces isomorphisms of cohomology with \mathbb{Z}/p -coefficients.

Wilkerson [14], Mimura, Nishida, and Toda [11] gave the mod p decompositions of exceptional Lie groups when they are torsion-free. The result was stated in the splitting theorem [2], 1.1; upon which we will be relying through Section 2 and Section 3. By the above definition and [2], 1.1; quasi p -regular Lie groups, when localized at p , split into a product of $B(2n + 1, 2n + 1 + q)$ and/or spheres. These are G_2, F_4, E_6 when $p \geq 5$, and E_7, E_8 when $p \geq 11$. We find a formula for $\exp_p(\Phi B(2n + 1, 2n + 1 + q))$ for all n and odd p .

PROPOSITION (2.7). *Let $B = B(2n + 1, 2n + 1 + q)$, and $q = 2(p - 1)$. Then*

$$\exp_p(\Phi B) = n + p.$$

Proof. In the sphere bundle $S^{2n+1} \rightarrow B \rightarrow S^{2n+1+q}$, the inclusion map $S^{2n+1} \cup e^{2n+1+q} \rightarrow B$ induces an isomorphism $K^1(S^{2n+1} \cup e^{2n+1+q}) \rightarrow QK^1(B)$, where Q denotes the indecomposables. So the Adams operations on $QK^1(B)$ are the same as the Adams operations on $K^1(S^{2n+1} \cup e^{2n+1+q})$. Adams [1], 7.5; tells that ψ^p in $K(S^{2n} \cup e^{2n+q})$ is given by

$$\psi^p(x) = p^n x + \lambda(p^{n+p-1} - p^n)y,$$

$$\psi^p(y) = p^{n+p-1}y.$$

Here λ and the e -invariant are equal by [1], 7.8; and the e -invariant, in particular, is $\frac{1}{p}$ according to [1], 12.4. Hence the Adams operations in $B = B(2n + 1, 2n + 1 + q)$ are as below.

$$\psi^p(x) = p^n x + \frac{u}{p} p^n (p^{p-1} - 1)y$$

$$\psi^p(y) = p^{n+p-1}y.$$

Here the coefficient u/p , with u a unit, can result from a different choice of generator. To calculate the p -exponent of $\Phi B(2n + 1, 2n + 1 + q)$, we consider $QK^1(B)/\psi^p$, which is an abelian group represented by two generators x and y with relations

$$p^n x + u' p^{n-1} y = 0,$$

$$p^{n+p-1} y = 0,$$

where $u' = u(p^{p-1} - 1)$ is a unit.

Subtract from the second equation the first one multiplied by $\frac{1}{u'} p^p$. They become

$$p^{n-1} \left(\frac{1}{u'} p x + y \right) = 0,$$

$$-\frac{1}{u'} p^{n+p} x = 0.$$

This implies that the abelian group M/ψ^p is a direct sum of $\mathbb{Z}/p^{n-1} \oplus \mathbb{Z}/p^{n+p}$ generated by $\frac{1}{w}px + y$ and x . Therefore

$$\exp_p(\Phi B(2n + 1, 2n + 1 + q)) = n + p. \quad \square$$

The results for $\exp_p(\Phi X)$ in Theorem (1.1) follow from Proposition (2.7) and [2], 1.1. For example, F_4 when localized at 5 is split into $B(3, 11) \times B(15, 23)$. By Proposition (2.7), $\exp_5(\Phi B(3, 11)) = 6$, and $\exp_5(\Phi B(15, 23)) = 12$. Thus $\exp_5(\Phi F_4) = \max\{6, 12\} = 12$.

Calculation of $\exp_p(\Phi X)$ for non-quasi p -regular cases

The non-quasi p -regular cases consist of $(G_2; 3), (F_4; 3), (E_6; 3), (E_7; 3), (E_7; 5), (E_7; 7), (E_8; 3), (E_8; 5)$, and $(E_8; 7)$. We calculate the p -exponent for $(\Phi E_7; 5)$ to illustrate the method.

Since $K^1(\Phi E_7) = PK^1(E_7)/\psi^5$, we need the Adams operation ψ^5 in $PK^1(E_7)$ localized at 5. First, the matrix whose rows are the eigenvectors of ψ^2 acting on $PK^1(E_7)$ and written in terms of a standard basis such as that in [7], 2.6; is given in (2.8), an analogue of the transpose of [7], 3.2. The matrix (2.8) was calculated using LIE and Maple by Davis during his work on [7] but is not included in [7].

$$(2.8) \quad \begin{pmatrix} 78784 & 6480 & 272 & 1 & 56 & 3101 & 211904 \\ 303293288 & 11940642 & 504934 & 1529 & 71742 & 991353 & -1658990256 \\ -4734664 & 273264 & 8050 & 35 & 2088 & 126843 & -7835040 \\ 145672 & -59052 & -514 & 1 & 228 & 52497 & -1650624 \\ -154936 & -20664 & 2350 & 5 & 192 & -7683 & 184800 \\ 16072 & -852 & -274 & 1 & 108 & -2463 & 38016 \\ 1672 & -252 & -34 & 1 & -12 & 177 & -1344 \end{pmatrix}$$

The eigenvectors which satisfy $\psi^2 v_i = 2^i v_i$ correspond to the sphere factors in a rational product decomposition of E_7 , and hence also satisfy $\psi^k v_i = k^i v_i$. See [7], (3.1) and (3.4).

The determinant turns out to be

$$(2.9) \quad 2^{31} 3^{16} 5^7 7^4 11^2 13^2 17.$$

When localized at 5, the eigenvectors in (2.8) do not span $PK^1(E_7)$ since there is a factor of 5^7 in the determinant. The following algorithm is to get rid of the factor 5^7 .

Let v_i be the vector formed by the i^{th} row in (2.8). Since $w_2 := (4v_2 - v_4)/5, w_5 := (4v_3 - v_5)/5, w_4 := (v_4 - v_6)/5$, and $w_6 := (v_6 - v_7)/5$ are integral, we replace v_2, v_3, v_4 , and v_6 by w_2, w_3, w_4 , and w_6 . Let M_2 denote the matrix $([v_1, w_2, w_3, w_4, v_5, w_6, v_7])$, where v_1 , etc., denote rows. Its determinant equals (2.9) divided by 5^4 . We then repeat this process twice more to get rid of the remaining 5^3 factor of the determinant. Replacing w_2 and w_4 by $x_2 := (2w_2 + 3w_4 - v_7)/5$ and $x_4 := (w_4 - w_6)/5$ we get $M_3 := ([v_1, x_2, w_3, x_4, v_5, w_6, v_7])$. Then replace v_1 by $z_1 := (3v_1 + 2x_2 + x_4 + 2w_6 - v_7)/5$ to get $M_4 := ([z_1, x_2, w_3, x_4, v_5, w_6, v_7])$, whose determinant is not divisible by 5 and so is a unit over $\mathbb{Z}_{(5)}$. Therefore the rows of M_4 span $PK^1(E_7)_{(5)}$ and form a basis. With this basis, for instance,

$$\begin{aligned}
 \psi^k(x_4) &= \psi^k((w_4 - w_6)/5) \\
 &= \psi^k\left(\frac{1}{25}v_4 - \frac{2}{25}v_6 + \frac{1}{25}v_7\right) \\
 &= \frac{1}{25}\psi^k(v_4) - \frac{2}{25}\psi^k(v_6) + \frac{1}{25}\psi^k(v_7) \\
 &= \frac{1}{25}k^9v_4 - \frac{2}{25}k^{13}v_6 + \frac{1}{25}k^{17}v_7 \\
 &= \frac{1}{25}k^9(25x_4 + 10w_6 + v_7) - \frac{2}{25}k^{13}(5w_6 + v_7) + \frac{1}{25}k^{17}v_7 \\
 &= k^9x_4 + \frac{2}{5}(k^9 - k^{13})w_6 + \frac{1}{25}(k^9 - 2k^{13} + k^{17})v_7.
 \end{aligned}$$

So the matrix of ψ^k under our new basis $\{z_1, x_2, w_3, x_4, v_5, w_6, v_7\}$ has

$$[0, 0, 0, k^9, 0, \frac{2}{5}(k^9 - k^{13}), \frac{1}{25}(k^9 - 2k^{13} + k^{17})]^T$$

as the fourth column. We wrote a computer program to calculate the rest of the columns of ψ^k by repeatedly replacing vectors to the final set of vectors. Here is the matrix of ψ^k .

(2.10)

$$\begin{bmatrix}
 k & 0 & 0 & 0 & 0 & 0 & 0 \\
 -\frac{2}{5}(k - k^5) & k^5 & 0 & 0 & 0 & 0 & 0 \\
 0 & 0 & k^7 & 0 & 0 & 0 & 0 \\
 -\frac{k+2k^5-3k^9}{5} & -k^5 + k^9 & 0 & k^9 & 0 & 0 & 0 \\
 0 & 0 & \frac{k^7-k^{11}}{5} & 0 & k^{11} & 0 & 0 \\
 \frac{2k(k^4-5+3k^8+k^{12})}{25} & \frac{k^5+2k^9-3k^{13}}{5} & 0 & \frac{2(k^9-k^{13})}{5} & 0 & k^{13} & 0 \\
 m & \frac{k^5(7+k^4-3k^8-5k^{12})}{25} & 0 & \frac{k^9(1-2k^4+k^8)}{25} & 0 & \frac{k^{13}-k^{17}}{5} & k^{17}
 \end{bmatrix},$$

where $m = \frac{25k+14k^5+3k^9+2k^{13}-44k^{17}}{125}$.

Note that in proving [7], 3.10; Davis performed a similar algorithm for all primes to get a basis for integral $PK^1(E_7)$. Because the formula for ψ^k in [7], 3.10; is so complicated, we prefer the basis for just $PK^1(E_7)/\psi^5$.

After obtaining the Adams operations in $PK^1(X)$, we can determine the whole group structure of $K^1(\Phi X)$. We use $k = p$ in the matrix. Since $K^1(\Phi X)$ is a direct sum of cyclic p -groups, i.e, $PK^1(X)/\psi^p = \mathbb{Z}/p^{e_1} \oplus \dots \oplus \mathbb{Z}/p^{e_r}$, we want to know what the orders p^{e_1}, \dots, p^{e_r} of the summands are. The largest p^{e_i} is the order of the identity map, and gives us the p -exponent of ΦX . The procedure which was used to calculate the p -exponent of $B(2n + 1, 2n + 1 + tq)$ can be expressed in terms of matrices in the following way.

$$\begin{bmatrix} p^n & up^{n-1} \\ 0 & p^{n+t(p-1)} \end{bmatrix} \longrightarrow \begin{bmatrix} \frac{1}{u}p^n & p^{n-1} \\ 0 & p^{n+t(p-1)} \end{bmatrix} \longrightarrow \begin{bmatrix} \frac{1}{u}p^n & p^{n-1} \\ \frac{1}{u}p^{n+t(p-1)+1} & 0 \end{bmatrix}.$$

We pivot on the entry with smallest p -exponent. Eliminating the row and column where p^{n-1} stands, it splits off a \mathbb{Z}/p^{n-1} summand generated by $\frac{1}{u}px + y$. What is left is a $\mathbb{Z}/p^{n+t(p-1)+1}$ generated by x .

For a larger matrix, it is hard to do these by hand. We wrote a computer program to do the following algorithm: Go through the matrix and find the entry with smallest p -exponent. If there are several, choose the first. Pivot on it, record the exponent. Remove the row and column. Then repeat.

Applying the algorithm to the above matrix with $p = 5$, we obtain the exponents, 3, 6, 8, 12, 14, 20, which indicate that when localized at $p = 5$,

$$PK^1(E_7)/\psi^5 = \mathbb{Z}/5^3 \oplus \mathbb{Z}/5^6 \oplus \mathbb{Z}/5^8 \oplus \mathbb{Z}/5^{12} \oplus \mathbb{Z}/5^{14} \oplus \mathbb{Z}/5^{20}.$$

Therefore $\exp_5(\Phi E_7) = 20$.

For the spectrum $(\Phi E_7, 7)$, we do the similar algorithm to (2.8) to get rid of the 7^4 factor in (2.9) by the following steps. Replace v_1 and v_2 by $w_1 := (v_1 + 5v_3 - v_6)/7$ and $w_2 := (v_2 + v_5 - v_7)/7$, then replace v_5 by $x_5 := (3v_5 - v_7)/7$, and finally replace w_2 by $z_2 := (w_2 + 3x_5 - v_7)/7$. Now the matrix $M_4 = [w_1, z_2, v_3, v_4, x_5, v_6, v_7]$ span $PK^1(E_7)_{(7)}$ and form a basis. With this basis, we obtain ψ^k and then run the computer program to get the exponents of the summands to be 3, 7, 9, 11, 14, 19.

For $(E_8, 3)$, $(E_8, 5)$, and $(E_8, 7)$, the matrix of eigenvectors is [7], 3.2. We use Maple to repeatedly replace vectors v by $(av_i + bv_j)/p$, where $(av_i + bv_j)$ is a linear combination of vectors of [7], 3.2; and $p = 3, 5, 7$ respectively to get rid of the 3^{32} , 5^{10} , 7^9 factors in the determinant of [7], 3.2. After we get nice bases to obtain ψ^k in each of these three cases we obtain the exponents of summands. The results for all cases appear in the table of Theorem (1.1). The procedure and all information regarding the Adams operations ψ^k for each case can be found in the Appendix of [10] or at <http://science.hec.edu/~xli/AdamsOperations.pdf>.

3. Cell structure of ΦX : torsion-free cases

We begin by proving that ΦX , the v_1 -periodic spectrum of an exceptional Lie group X , can be built up by fibrations from ΦS^{2i+1} .

The p -local exceptional Lie groups that are torsion-free, listed in [2], (1.1); can be built up by fibrations from odd dimensional spheres. Such spaces are called spherically resolved [5]. For instance, the space $(F_4, 5)$ is built up from spheres S^3, S^{11}, S^{15} , and S^{23} by fibrations. Since Φ preserves homotopy fibrations, the v_1 -periodic spectrum of these exceptional Lie groups can be built up by fibrations from ΦS^{2i+1} .

Definition (3.1) ([3], 11.2). An object of \mathbb{A} is algebraically spherically resolved (ASR) if there exist short exact sequences in \mathbb{A} ,

$$(3.2) \quad 0 \longrightarrow QK^1(S^{2n_i+1}) \longrightarrow M_i \longrightarrow M_{i-1} \longrightarrow 0$$

for $0 \leq i \leq k$, with $M_{-1} = 0$ and $M_k = M$.

The following result of Bendersky and Thompson is very useful.

LEMMA (3.3) ([5], 2.1). *Let*

$$0 \longrightarrow M_1 \longrightarrow M_2 \longrightarrow M_3 \longrightarrow 0$$

be a short exact sequence of stable p -adic Adams modules. Then

$$\mathcal{M}(M_3, 1) \longrightarrow \mathcal{M}(M_2, 1) \longrightarrow \mathcal{M}(M_1, 1)$$

is a fiber sequence of spectra.

Using Lemma (3.3), we prove

THEOREM (3.4). *If X is a compact simple Lie group and p is an odd prime, then ΦX is spherically resolved in the sense that it is built from various ΦS^{2i+1} by fibrations.*

Proof. For a compact simple Lie group X , the matrix of Adams operations on $QK^1(X)$ can be brought to triangular form as in the above example. This implies that it is ASR; i.e., there are short exact sequences of Adams modules

$$0 \rightarrow S_i \rightarrow M_i \rightarrow M_{i-1} \rightarrow 0$$

with $S_i = QK^1(S^{2n_i+1})$ and $M_k = QK^1(X)$. Modding out by ψ^p ,

$$0 \rightarrow S_i/\psi^p \rightarrow M_i/\psi^p \rightarrow M_{i-1}/\psi^p \rightarrow 0$$

is a short exact sequence of stable Adams module by the Snake Lemma since ψ^p acts injectively on M_i . This follows from (3.2) and the injectivity of the action of ψ^p on $QK^1(S^{2n_i+1})$. Then by Lemma (3.3),

$$(3.5) \quad \mathcal{M}(M_{i-1}/\psi^p, 1) \rightarrow \mathcal{M}(M_i/\psi^p, 1) \rightarrow \mathcal{M}(S_i/\psi^p, 1)$$

is a fiber sequence of spectra. Here $\mathcal{M}(M, 1)$ refers to the spectrum defined in (2.3). Since $\mathcal{M}(S_i/\psi^p, 1) = \Phi S^{2n_i+1}$, we obtain the desired conclusion. \square

We illustrate our method of detecting attaching maps for torsion-free cases by analyzing the cell structure in $(\Phi E_7, 7)$.

The matrix of the Adams operation ψ^7 in $K^*(\Phi E_7, 7)$, computed by Davis during his work on [7], is given by

$$(3.6) \quad \begin{pmatrix} 7 & 0 & 0 & 0 & 0 & 0 & 0 \\ 0 & 7^5 & 0 & 0 & 0 & 0 & 0 \\ -\frac{5(7-7^7)}{7} & 0 & 7^7 & 0 & 0 & 0 & 0 \\ 0 & 0 & 0 & 7^9 & 0 & 0 & 0 \\ 0 & -\frac{10}{21}(7^5 - 7^{11}) & 0 & 0 & 7^{11} & 0 & 0 \\ \frac{7-7^{13}}{7} & 0 & 0 & 0 & 0 & 7^{13} & 0 \\ 0 & \frac{7^5(23+10\cdot 7^6-33\cdot 7^{12})}{147} & 0 & 0 & \frac{7^{11}-7^{17}}{7} & 0 & 7^{17} \end{pmatrix}$$

This matrix is analogous to (2.10) with $k = 7$, except that some more change of basis has been performed to obtain a better splitting.

Let M_i be the upper $i \times i$ submatrix of (3.6). As in the proof of Theorem (3.4), there are fibrations of spectra

$$(3.7) \quad \mathcal{M}(M_2/\psi^p, 1) \rightarrow \mathcal{M}(M_3/\psi^p, 1) \rightarrow \mathcal{M}(S_3/\psi^p, 1).$$

Here $\mathcal{M}(S_3/\psi^p, 1) = \Phi S^{15}$ by [6], 3.4 and Theorem (2.3). By Proposition (3.8), $\mathcal{M}(M_2/\psi^p, 1) = \Phi S^3 \vee \Phi S^{11}$.

Let $X(3, 11, 15)$ denote the spectrum $\mathcal{M}(M_3/\psi^p, 1)$. In general, the notation $X(-, \dots, -)$ just refers to a spectrum built from ΦS^{2n+1} of the indicated dimensions by fibrations. Then (3.7) becomes

$$\Phi S^3 \vee \Phi S^{11} \rightarrow X(3, 11, 15) \rightarrow \Phi S^{15}.$$

In the category of spectra, fibrations and cofibrations are the same thing. Therefore we have a cofiber sequence

$$\Sigma^{-1}\Phi S^{15} \xrightarrow{\alpha} \Phi S^3 \vee \Phi S^{11} \rightarrow X(3, 11, 15) \rightarrow \Phi S^{15} \rightarrow \Sigma(\Phi S^3 \vee \Phi S^{11})$$

The spectrum $X(3, 11, 15)$ is the cofiber of the map α . By Theorem (2.4), the map α is classified by

$$\begin{aligned} & \text{Ext}_A^1 (PK^1(S^3)/\psi^p \oplus PK^1(S^{11})/\psi^p, PK^1(S^{15})) \\ &= \text{Ext}_A^{1,15} (PK^1(S^3)/\psi^p) \oplus \text{Ext}_A^{1,15} (PK^1(S^{11})/\psi^p) \\ &= v_1^{-1}\pi_{14}(S^3) \oplus v_1^{-1}\pi_{14}(S^{11}) \\ &= \mathbb{Z}/7 \text{ generated by } \alpha_1 \end{aligned}$$

Our concern is which element of this group does our attaching map α equal? Does $\alpha = 0$ or $\alpha = \alpha_1$? We answer this question and generalize the above analysis in the following proposition.

Here and later, we will denote the linear transformation ψ^k by its matrix with respect to a certain basis.

PROPOSITION (3.8). *For a fibration $\Phi S^{2n+1} \rightarrow E \rightarrow \Phi S^{2n+2p-1}$, either $E = \Phi S^{2n+1} \vee \Phi S^{2n+2p-1}$, in which case*

$$\psi^k = \begin{bmatrix} k^n & 0 \\ 0 & k^{n+p-1} \end{bmatrix},$$

or $E = \Phi B(2n + 1, 2n + 2p - 1)$ with α_1 attaching map, in which case

$$(3.9) \quad \psi^k = \begin{bmatrix} k^n & 0 \\ \frac{u}{p}k^n(k^{p-1} - 1) & k^{n+p-1} \end{bmatrix}$$

where u is a unit in $\mathbb{Z}_{(p)}$.

Proof. By an argument similar to that used just above, there is a cofiber sequence

$$\Sigma^{-1}\Phi S^{2n+2p-1} \xrightarrow{f} \Phi S^{2n+1} \rightarrow E \rightarrow \Phi S^{2n+2p-1}.$$

So E is the cofiber of a map f . Possible maps f are classified by (2.5) with $\Sigma^2 E = \Phi S^{2n+2p-1}$. Explicitly, they are classified by

$$\begin{aligned} \text{Ext}_A^1(PK^1(S^{2n+1})/\text{im } \psi^p, PK^1(S^{2n+2p-1})) &= \text{Ext}_A^{1,2n+2p-1}(PK^1(S^{2n+1})/\text{im } \psi^p) \\ &= v_1^{-1}\pi_{2n+2p-2}(S^{2n+1}) \\ &= \mathbb{Z}/p \text{ generated by } \alpha_1 \end{aligned}$$

There are two possibilities: either $f = 0$ or $f = \alpha_1$. If $f = 0$, then E is a product of ΦS^{2n+1} and $\Phi S^{2n+2p-1}$ and the Adams operations in $K^*(E)$ split, i.e. $\psi^k = \begin{bmatrix} k^n & 0 \\ 0 & k^{n+p-1} \end{bmatrix}$. If $f = \alpha_1$, then $E = \Phi B(2n + 1, 2n + 2p - 1)$ and the Adams operations in $K^*(-)$ are as in (3.9) by the same argument as in the proof of Proposition (2.7). □

In the case when $k = p$ with which we deal, (3.9) becomes

$$\psi^p = \begin{bmatrix} p^n & 0 \\ u'p^{n-1} & p^{n+p-1} \end{bmatrix}$$

where $u' = u(p^{p-1} - 1)$.

Whereas in ordinary homotopy theory, a cell complex such as $S^3 \cup_\alpha e^7$ is sometimes denoted by $(3) \frown (7)$, here we are dealing with spectrum forms

such as $\Phi S^3 \cup C(\Sigma^{-1}\Phi S^7)$ and will denote this by $\textcircled{3} \overset{\curvearrowright}{\textcircled{7}}$. If $C(\Sigma^{-1}\Phi S^7)$ is attached trivially, this becomes $\Phi S^3 \vee \Sigma \Sigma^{-1}\Phi S^7$ which is just $\Phi S^3 \vee \Phi S^7$. For example, the spectrum $\Phi E_{6(7)}$ decomposes as

$$\Phi S^3 \cup_{\alpha_1} C(\Sigma^{-1}\Phi S^{15}) \vee (\Phi S^{11} \cup_{\alpha_1} C(\Sigma^{-1}\Phi S^{23})) \vee \Phi S^9 \vee \Phi S^{17}$$

will be denoted as

$$(3.10) \quad \textcircled{3} \text{---} \textcircled{15} \quad \textcircled{11} \text{---} \textcircled{23} \quad \textcircled{9} \quad \textcircled{17}$$

By the property stated in Proposition (3.8), the number $-\frac{5}{7}(7 - 7^7)$ in row 3, column 1 in (3.6) indicates that the cells $\textcircled{3}$ and $\textcircled{15}$ are attached by α_1 . The cell $\textcircled{11}$ does not attach to the $\textcircled{3}$ cell because the Adams operation splits. So the spectrum $X(3, 11, 15)$ is built as

$$\textcircled{3} \text{---} \textcircled{15} \quad \textcircled{11}$$

The cell $\textcircled{19}$ does not attach to any cell since the Adams operation splits on the top generator in M_4 .

By a similar analysis, the cell $\textcircled{23}$ is attached to the cell $\textcircled{11}$ by α_1 because the number in row 5, column 2 is $-\frac{10}{21}(7^5 - 7^{11})$. And because of the zeros in row 5, column 1 and in row 5, column 3, the cell $\textcircled{23}$ is not attached to either $\textcircled{3}$ or $\textcircled{15}$. The cell structure for $\Phi E_{7(7)}$ we may see so far is as below,

$$\textcircled{3} \text{---} \textcircled{15} \quad \textcircled{11} \text{---} \textcircled{23} \quad \textcircled{19}$$

The attaching map β for the $\textcircled{27}$ cell is an element of

$$\text{Ext}_A^1(M_5/\text{im } \psi^p, K^1\Phi(S^{27})),$$

where $\mathcal{M}(M_5/\text{im } \psi^p, 1) = X(3, 15, 11, 23, 19)$.

$$\begin{aligned} & \text{Ext}_A^1(M_5/\text{im } \psi^p, PK^1(S^{27})) \\ &= \text{Ext}_A^{1,27}(PK^1(B(3, 15))/\psi^p) \oplus \text{Ext}_A^{1,27}(PK^1(B(11, 23))/\psi^p) \\ & \quad \oplus \text{Ext}_A^{1,27}(PK^1(S^{19})/\psi^p) \\ &= v_1^{-1}\pi_{26}(B(3, 15)) \oplus v_1^{-1}\pi_{26}(B(11, 23)) \oplus v_1^{-1}\pi_{26}(S^{19}) \\ &= \mathbb{Z}/7 \oplus 0 \oplus 0, \text{ with } \mathbb{Z}/7 \text{ generated by } \alpha_2 \end{aligned}$$

The calculation of these v_1 -periodic homotopy groups are according to [5], 1.2, 1.3.

Again we are concerned with which element of the group $\mathbb{Z}/7$ does our attaching map β equal? It is detected by ψ^k in the following proposition, which is proved similarly to Proposition (3.8).

PROPOSITION (3.11). *For a fibration $\Phi S^{2n+1} \rightarrow E \rightarrow \Phi S^{2n+1+4(p-1)}$, either $E = \Phi S^{2n+1} \vee \Phi S^{2n+1+2q}$ where*

$$\psi^k = \begin{bmatrix} k^n & 0 \\ 0 & k^{n+2q} \end{bmatrix}$$

or $E = \Phi B(2n + 1, 2n + 1 + 2q)$ with α_2 the attaching map. In this case

$$(3.12) \quad \psi^k = \begin{bmatrix} k^n & 0 \\ \frac{u}{p} k^n (k^{2(p-1)} - 1) & k^{n+2q} \end{bmatrix}$$

where u is a unit in $\mathbb{Z}_{(7)}$.

When $k = p$, (3.12) becomes

$$\psi^p = \begin{bmatrix} p^n & 0 \\ u' p^{n-1} & p^{n+2q} \end{bmatrix}$$

where $u' = u(p^{2q} - 1)$ is a unit.

By this proposition, the number $\frac{1}{7}(7 - 7^{13})$ in row 6, column 1 tells that the cell (27) is attached to (3) by α_2 . So far, $\Phi E_{7(\tau)}$ has been built up as

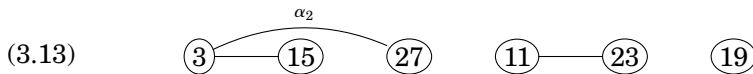

The attaching map for the (35) -cell is an element of

$$\text{Ext}_A^1(M_6/\psi^p, K^1(\Phi S^{35}))$$

where $\mathcal{M}(M_6/\psi^p, 1) = X(3, 15, 27, 11, 23, 19)$. We calculate this group in the following.

$$\begin{aligned} & \text{Ext}_A^1(M_6/\psi^p, K^1(\Phi S^{35})) \\ &= \text{Ext}_A^{1,35}(PK^1(B(3, 15, 27))/\psi^p) \oplus \text{Ext}_A^{1,35}(PK^1(B(11, 23))/\psi^p) \\ & \oplus \text{Ext}_A^{1,35}(PK^1(S^{19})/\psi^p) \\ &= v_1^{-1}\pi_{34}(B(3, 15, 27)) \oplus v_1^{-1}\pi_{34}(B(11, 23)) \oplus v_1^{-1}\pi_{34}(S^{19}) \\ &= 0 \oplus \mathbb{Z}/p^2 \oplus 0 \\ &= \mathbb{Z}/p^2 \end{aligned}$$

The calculation of the v_1 -periodic homotopy groups are according to [5], 1.2, 1.3, and 1.4.

Since the number in the last row and 5th column in (3.6) is $\frac{1}{7}(7^{11} - 7^{17})$, the attaching map for (35) -cell is an α_1 following Proposition (3.8).

Therefore, the cell structure for the spectrum $\Phi E_{7(\tau)}$ is as below:

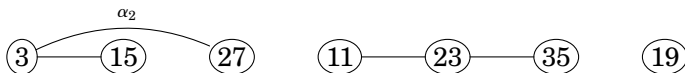

By similar analysis, we obtain cell structure for all the other $(\Phi X, p)$ when X is a torsion-free exceptional Lie group. Our result is in Theorem (1.2).

4. Cell Structure of $\Phi(X)$: torsion cases

In this section, we analyze the attaching maps between cells in ΦX for X a torsion exceptional Lie group using a change-of-basis method. The correspondence between certain coefficients and the attaching map between associated cells is given in the next two propositions.

PROPOSITION (4.1). *Let $f: S^{2n+tq} \rightarrow S^{2n+1}$ be any map and $t \not\equiv 0 \pmod{p}$. The matrix of Adams operations in $PK^1(S^{2n+1} \cup_f e^{2n+1+tq})$ is of the form*

$$(4.2) \quad \psi^k = \begin{bmatrix} k^n & 0 \\ a(k^n - k^{n+t(p-1)}) & k^{n+t(p-1)} \end{bmatrix}$$

for any integer k , where $a \in \mathbb{Q}$ is

1. either a number in $\mathbb{Z}_{(p)}$
2. or $\frac{1}{p} \cdot u$ with $u \in \mathbb{Z}_{(p)}$ a unit.

In the first case, we can change the basis to get $\psi^k = \begin{bmatrix} k^n & 0 \\ 0 & k^{n+t(p-1)} \end{bmatrix}$ and the attaching map f is then trivial. In the second case, the attaching map is α_t and we cannot get a diagonal matrix.

Proof. Let n and p be fixed. Suppose that $\psi^k = \begin{bmatrix} k^n & 0 \\ c_k & k^{n+t(p-1)} \end{bmatrix}$ for any k .

From $\psi^k \psi^l = \psi^l \psi^k$ it follows

$$(4.3) \quad c_l(k^n - k^{n+t(p-1)}) = c_k(l^n - l^{n+t(p-1)}), \text{ for all } k, l.$$

Thus the number $\frac{c_k}{k^n - k^{n+t(p-1)}}$ is independent of k ; we call it a . Then $c_k = a(k^n - k^{n+t(p-1)}) = -a \cdot k^n(k^{t(p-1)} - 1)$ for any k . We choose k as a generator of $(\mathbb{Z}/p^2)^\times$, which is a cyclic group of order $p(p-1)$. Then $k^{p-1} \not\equiv 1 \pmod{p^2}$ and moreover $k^{t(p-1)} \not\equiv 1 \pmod{p^2}$ for any $t \not\equiv 0 \pmod{p}$. This says that $k^{t(p-1)} - 1$ is not a multiple of p^2 . However, $k^{t(p-1)} - 1$ is a multiple of p by Fermat's Little Theorem.

Since ψ^k is the Adams operation in $K_{(p)}(-)$, $c_k = -a \cdot k^n(k^{t(p-1)} - 1)$ is in $\mathbb{Z}_{(p)}$. To ensure this, the number a has to be either in $\mathbb{Z}_{(p)}$ or equal to $\frac{1}{p}$ unit, that is, a has at most one factor of p in its denominator. \square

A quick application of this proposition is to see the cell structure for $\Phi F_{4(3)}$. Davis [7], 3.8; gives the Adams operations ψ^k on $PK^1(\Phi F_4)_{(3)}$ as

$$(4.4) \quad \begin{bmatrix} k & 0 & 0 & 0 \\ -\frac{1}{10}(k - k^5) & k^5 & 0 & 0 \\ -\frac{k}{70} + \frac{k^5}{120} + \frac{k^7}{168} & \frac{1}{12}(k^5 - k^7) & k^7 & 0 \\ -\frac{k}{4620} + \frac{k^5}{6720} + \frac{k^7}{13440} - \frac{k^{11}}{147840} & \frac{k^5}{672} - \frac{k^7}{960} - \frac{k^{11}}{2240} & \frac{k^7 - k^{11}}{80} & k^{11} \end{bmatrix}$$

With twice change-of-basis, (4.4) becomes

$$(4.5) \quad \begin{bmatrix} k & 0 & 0 & 0 \\ 0 & k^5 & 0 & 0 \\ 0 & \frac{k^5 - k^7}{12} & k^7 & 0 \\ \frac{k - k^{11}}{147840} & 0 & 0 & k^{11} \end{bmatrix}$$

The zeros tell that the spectrum $\Phi F_{4(3)}$ splits into a wedge of two parts, which are built from the cells (3) and (23) and the cells (11) and (15), respectively. By Proposition (4.1), the spectrum $\Phi F_{4(3)}$ is built up as

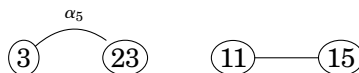

Here we also use the fact that $\mathcal{M}(M_1 \oplus M_2, 1) \approx \mathcal{M}(M_1, 1) \vee \mathcal{M}(M_2, 1)$.

Proposition (4.1) gives the information of how the coefficient in the Adams operations relates to the attaching map between cells $(2n + 1)$ and $(2n + 1 + tq)$ when t is not a multiple of p . In the case when t is a multiple of p , the result is given by the following proposition, which is proved similarly to Proposition (4.1). We let $t = jp$ for convenience, where j is not a multiple of p . We use the standard notation [13], 1.3.11; that α_t is the element of order p in the $(tq - 1)$ -stem.

PROPOSITION (4.6). *Let $f : S^{2n+jpq} \rightarrow S^{2n+1}$ be any map, with $j \not\equiv 0(p)$.*

1. *Let $n > 1$. Then the homotopy group $\pi_{2n+jpq}(\Phi S^{2n+1})$ is \mathbb{Z}/p^2 , and the matrix of Adams operations in $PK^1(S^{2n+1} \cup_f e^{2n+1+jpq})$ is of the form*

$$(4.7) \quad \psi^k = \begin{bmatrix} k^n & 0 \\ \lambda(k^n - k^{n+jp(p-1)}) & k^{n+jp(p-1)} \end{bmatrix}.$$

The number λ has the form $\frac{u}{p^e}$, where u is a unit in $\mathbb{Z}_{(p)}$ and $e = 0, 1$, or 2 . The attaching map is of one of the three cases

- i. If $\lambda = \frac{u}{p^2}$, the attaching map f is a generator of \mathbb{Z}/p^2 called $\frac{1}{p}\alpha_t$.
- ii. If $\lambda = \frac{u}{p}$, the attaching map f is $p \cdot$ gen, called α_t (since it is the element of order p).
- iii. If $\lambda \in \mathbb{Z}_{(p)}$, the attaching map is trivial.

2. *If $n = 1$, the homotopy group is \mathbb{Z}/p . The coefficient λ can only be of type (ii) or (iii) and so the attaching map is the generator or trivial as in cases (ii) or (iii) above.*

According to [7], 6.1; the matrix of Adams operations in $PK^1(E_8, \mathbb{Z}_{(3)})$ on a certain basis is given by (4.8) below.

$$(4.8) \quad \begin{bmatrix} 3 & 0 & 0 & 0 & 0 & 0 & 0 & 0 & 0 \\ \frac{730(3^7-3)}{3} & 3^7 & 0 & 0 & 0 & 0 & 0 & 0 & 0 \\ m & 9(3^{11} - 3^7) & 3^{11} & 0 & 0 & 0 & 0 & 0 & 0 \\ \# & n & \frac{3^{11}-3^{13}}{3} & 3^{13} & 0 & 0 & 0 & 0 & 0 \\ \# & \# & \# & \frac{3^{13}-3^{17}}{3} & 3^{17} & 0 & 0 & 0 & 0 \\ \# & \# & \# & \# & \frac{3^{19}-3^{17}}{3} & 3^{19} & 0 & 0 & 0 \\ \# & \# & \# & \# & \# & \frac{2(3^{19}-3^{23})}{3} & 3^{23} & 0 & 0 \\ \# & \# & \# & \# & \# & \# & \frac{3^{23}-3^{29}}{9} & 3^{29} & 0 \end{bmatrix}$$

Here $m = \frac{6560}{3} \cdot 3 - 2190 \cdot 3^7 + \frac{10}{3} \cdot 3^{11}$ and $n = -\frac{34}{9} \cdot 3^7 + 3 \cdot 3^{11} + \frac{7}{9} \cdot 3^{13}$. The #'s are numbers given in [7], 6.1; which are not relevant to our discussion.

The attaching map for the (15)-cell lies in $v_1^{-1}\pi_{14}(S^3) = \mathbb{Z}/p$, which is generated by α_3 . The first number in the second row, $-\frac{730}{3}(k - k^7)$, has a coefficient of type (ii) in Proposition (4.6). So α_3 is present. The attaching map for the (23)-cell is in $v_1^{-1}\pi_{22}(B(3, 15)) = \mathbb{Z}/p$ ([7], 6.4,c). By a change of basis

$$\begin{bmatrix} 3 & 0 & 0 \\ -\frac{730}{3}(3 - 3^7) & 3^7 & 0 \\ \frac{6560}{3} \cdot 3 - 2190 \cdot 3^7 + \frac{10}{3} \cdot 3^{11} & -9(3^7 - 3^{11}) & 3^{11} \end{bmatrix}$$

becomes

$$\begin{bmatrix} 3 & 0 & 0 \\ -\frac{730}{3}(3-3^7) & 3^7 & 0 \\ -\frac{10}{3}(3-3^{11}) & 0 & 3^{11} \end{bmatrix}.$$

The first number in the third row has a coefficient of type (ii) in Proposition (4.1) so α_5 is the attaching map between the $\textcircled{23}$ -cell and the $\textcircled{3}$ -cell.

In general, the group $\pi_{2k}(\Phi X)$ is presented by the matrix

$$\begin{bmatrix} (\psi^p)^T \\ (\psi_r - r^k)^T \end{bmatrix}$$

where r is a generator of the group of units mod p^2 ([6]).

The attaching map for the $\textcircled{27}$ -cell is in $\pi_{26}(\Phi B(3, 15, 23))$. This group is presented by the matrix

$$(4.9) \quad \begin{bmatrix} 3 & -\frac{730}{3}(3-3^7) & \frac{6560}{3} \cdot 3 - 2190 \cdot 3^7 + \frac{10}{3} \cdot 3^{11} \\ 0 & 3^7 & -9(3^7 - 3^{11}) \\ 0 & 0 & 3^{11} \\ 2 - 2^{13} & -\frac{730}{3}(2-2^7) & \frac{6560}{3} \cdot 2 - 2190 \cdot 2^7 + \frac{10}{3} \cdot 2^{11} \\ 0 & 2^7 - 2^{13} & -9(2^7 - 2^{11}) \\ 0 & 0 & 2^{11} - 2^{13} \end{bmatrix}$$

Computer calculation of an algorithm described in Section 2 shows that the group is a cyclic group of $\mathbb{Z}/3^3$. The number in position (4, 3) of matrix (4.8) tells that $\textcircled{27}$ is attached to $\textcircled{23}$ by α_1 by Proposition (4.1). So far, the cell structure for the first four cells is as below.

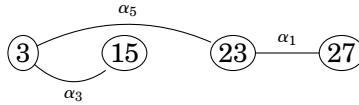

The cell $\textcircled{23}$ is not attached to $\textcircled{15}$ because the off-diagonal number below 3^7 in (4.8) is of type (i) in Lemma (4.1), which can be removed after a change of basis. Because the $\textcircled{23}$ and $\textcircled{15}$ are not attached to each other, it can happen that the cell $\textcircled{27}$ is attached to both $\textcircled{23}$ and $\textcircled{15}$. If we do a change of basis, the submatrix

$$\begin{bmatrix} 3^7 & 0 & 0 \\ -9(3^7 - 3^{11}) & 3^{11} & 0 \\ -\frac{34}{9} \cdot 3^7 + 3 \cdot 3^{11} + \frac{7}{9} \cdot 3^{13} & \frac{1}{3}(3^{11} - 3^{13}) & 3^{13} \end{bmatrix}$$

becomes

$$\begin{bmatrix} 3^7 & 0 & 0 \\ 0 & 3^{11} & 0 \\ -\frac{34}{9}(3^7 - 3^{13}) & \frac{1}{3}(3^{11} - 3^{13}) & 3^{13} \end{bmatrix}$$

The coefficient $-\frac{34}{3^2}$ is of type (i) in Proposition (4.6), which indicates that $\textcircled{27}$ is attached to $\textcircled{15}$ by $\frac{1}{3}\alpha_3$. Here we apply Proposition (4.6) since the difference between the exponent 13 and 7 is $p(p-1)$.

In the homotopy exact sequence point of view, there is an exact sequence for the inclusions $\Phi S^3 \hookrightarrow \Phi X(3, 15, 23)$,

$$\begin{array}{ccccc} \pi_{26}(\Phi S^3) & \xrightarrow{i} & \pi_{26}(\Phi X(3, 15, 23)) & \xrightarrow{\partial} & \pi_{26}(\Phi S^{15}) \oplus \pi_{26}(\Phi S^{23}) \\ \mathbb{Z}/3 & & \mathbb{Z}/27 & & \mathbb{Z}/9 \oplus \mathbb{Z}/3 \\ g_1 & & g_2 & & g_3 \quad g_4 \end{array}$$

The g_i 's below each group denote the generator of that group. We know that α_1 is present between (23) and (27) by the number $\frac{1}{3}(3^{11} - 3^{13})$. The attaching map for the (27) cell is a generator of $\mathbb{Z}/27$. The generator of $\mathbb{Z}/27$ must also map to the generator of $\mathbb{Z}/9$ because $3 \cdot g_2$ is not in the $\text{Im}(i) = \ker(\partial)$. So an element in $\pi_{26}(\Phi X(3, 15, 23))$ which is attached to (23) by α_1 is also attached to (15) by $\frac{1}{3}\alpha_3$.

The cell structure for the first four cells is therefore

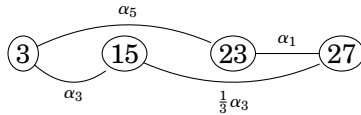

For the remaining attaching maps, we do the same algorithm as we did for $\pi_{26}(\Phi X(3, 15, 23))$. It turns out all the groups, $\pi_{34}(\Phi X(3, 15, 23, 27))$, $\pi_{38}(\Phi X(3, 15, 23, 27, 35))$, $\pi_{46}(\Phi X(3, 15, 23, 27, 35, 49))$, and $\pi_{58}(\Phi X(3, 15, 23, 27, 35, 39, 47))$ are cyclic. By Proposition 4.1, there is an α_2 attaching (35) to (27), an α_1 attaching (39) and (35), and another α_2 attaching (47) to (39). By Proposition (4.6), the cell (59) is attached to (47) by $\frac{1}{3}\alpha_3$.

Therefore the spectrum $(\Phi E_8, 3)$ can be built by fibrations from ΦS^n according to the scheme in diagram (4.10)

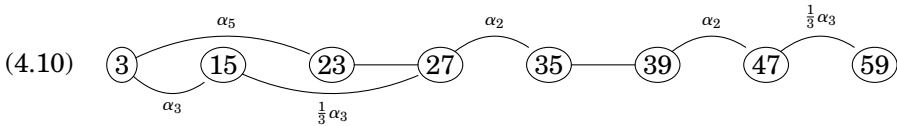

In [7], Davis speculated about a cell structure for this case. The reader may notice that there is some difference between [7], Diagram 6.2; and Diagram (4.10). A slight difference, explicitly, is that the attaching map between (3) and (15) is called $3\alpha_3$ and the attaching map between (47) and (59) is α_3 in [7], Diagram 6.2. This is because Davis used a different notation at the time. He interpreted α_k to mean the generator of the homotopy group, while we denote it as the element of order p . Another difference is that in Diagram (4.10) the (27) cell is also attached to (15) by $\frac{1}{3}\alpha_3$, which was apparently overlooked in [7].

The other cases of Theorem (1.3) are proved similarly.

5. Acknowledgements

Most of the results presented in this paper appear in the author's Ph.D. Dissertation. The author would like to thank Professor Davis for his guidance and help during preparation of the dissertaton and this work. The author

would also like to thank Emory & Henry College's Summer Starter Grant for support on this work.

Received July 8, 2008

Final version received May 14, 2009

EMORY & HENRY COLLEGE
EMORY, VA 24327
USA
xli@ehc.edu

REFERENCES

- [1] J. F. ADAMS, *On the groups $J(X)$, IV*, *Topology* **5** (1966) 21–71.
- [2] M. BENDERSKY, D. M. DAVIS, AND M. MIMURA, *v_1 -periodic homotopy groups of exceptional Lie groups: torsion-free cases*, *Trans. Amer. Math. Soc.* **333** (1992).
- [3] M. BENDERSKY AND D. M. DAVIS, *v_1 -periodic homotopy groups of $SO(n)$* , *Mem. Amer. Math. Soc.* **815** (2004).
- [4] M. BENDERSKY AND D. M. DAVIS, *3-primary v_1 -periodic homotopy groups of F_4 and E_6* , *Trans. Amer. Math. Soc.* **344**, (1994) 291–306.
- [5] M. BENDERSKY AND R. THOMPSON, *Some properties of the K -theory Completion*, *Contemp. Math.*, **293** (2002) 35–40.
- [6] A. K. BOUSFIELD, *The K -theory localizations and v_1 -periodic homotopy groups of H -spaces*, *Topology* **38** (1999) 1239–1264.
- [7] D. M. DAVIS, *From representation theory to homotopy groups*, *Mem. Amer. Math. Soc.* **759** (2002).
- [8] M. J. FISHER, *The p -exponent of the $K(1)_*$ -Local Spectrum $\Phi SU(n)$* , *Proc. Amer. Math. Soc.* **131**, (2003) 3617–3621.
- [9] L. HODGKIN, *On the K -theory of Lie groups*, *Topology* **6** (1967), 1–35.
- [10] X. LI, *Some properties of the v_1 -periodic spectrum associated to exceptional Lie groups*, Ph.D. Dissertation, Lehigh University, 2007.
- [11] M. MIMURA, G. NISHIDA, AND H. TODA, *Mod p decomposition of compact Lie groups*, *Publ. Res. Inst. Math. Sci.* **13** (1977), 627–680.
- [12] K. POTOCKA, *The number of summands in v_1 -periodic homotopic groups of $SU(n)$* , *Topology App.*, **153**, Issue 4, (2005), 647–677.
- [13] D. C. RAVENEL, *Complex cobordism and the stable homotopy groups of spheres*, *Pure and Applied Mathematics*, 121 Academic Press, Inc., Orlando, FL, 1986.
- [14] C. WILKERSON, *Self-maps of classifying spaces*, *Lecture Notes in Math.*, **418**, 150–157, Springer Verlag, Berlin, 1974.

THE VECTOR FIELD PROBLEM FOR PROJECTIVE STIEFEL MANIFOLDS

Dedicado afectuosamente a la memoria de Guillermo Moreno—un entusiasta de las álgebras de Cayley-Dickson y sus aplicaciones en topología

JÚLIUS KORBAŠ AND PETER ZVENGROWSKI

ABSTRACT. Results for the vector field problem on projective Stiefel manifolds $X_{n,r} \cong O(n)/(O(n-r) \times \mathbb{Z}_2)$, $2 \leq r < n$, are derived here; $X_{n,1}$ is $(n-1)$ -dimensional real projective space, for which these results are classical. In particular, $\text{span}(X_{n,r})$ for $r = 2, 3, 4$, for suitable (infinitely many) values of n is calculated. If $r = 2$ and n is odd, then additional difficulties present themselves, and one approach to dealing with this case using the Browder-Dupont invariant is discussed. Furthermore, when $n = 8m - 1$, by using an explicit version of the Hurwitz-Radon multiplications, we improve the lower bound for $\text{span}(X_{n,2})$ to $\text{span}(S^n)$. Two general results and some conjectures on the span of $X_{n,r}$ are also presented.

1. Introduction

The span of a finite dimensional real vector bundle α over a space X , denoted $\text{span}(\alpha)$, is k if α admits k , but no more than k , everywhere linearly independent cross-sections. If X is paracompact, then $\text{span}(\alpha) \geq k$ means that $\alpha \approx \eta \oplus k\varepsilon$ for some vector bundle η ; here and in the sequel ε is the trivial line bundle and $k\varepsilon$ denotes the k -fold Whitney sum of ε with itself.

For a q -dimensional smooth connected manifold M^q , one defines its span to be $\text{span}(M^q) := \text{span}(TM^q)$, where TM is the tangent bundle of M . The manifold M^q is parallelizable if its span is q . The problem of determining the number $\text{span}(M)$ is referred to as the vector field problem on M (further information can be found in [16], [18], [19], [20], [34]).

Besides the span of a manifold one can consider its stable span ([16], [18], [19], [20]):

$$(1.1) \quad \text{span}^0(M) := \text{span}(TM \oplus \varepsilon) - 1.$$

We remark that the stable span of a given smooth closed manifold M is interesting even if one is not able to find its span, in the context of fold maps (a smooth map $f: M^q \rightarrow N^p$ with $q \geq p$ is a fold map if all of its singular points are of fold type; a singular point $x \in M$ is of fold type if for some local coordinates around x and $f(x)$ one can write f as the assignment $(x_1, \dots, x_q) \mapsto (x_1, \dots, x_{p-1}, \pm x_p^2 \pm x_{p+1}^2 \pm \dots \pm x_q^2)$; in particular if $N^p = \mathbb{R}$, then a fold map is a Morse function on M). By Y. Ando (cf. [30]), if $\dim(M) = q$ and $\text{span}^0(M) \geq p - 1$ for some p such that $q \geq p \geq 2$, then there exists a fold map

2000 *Mathematics Subject Classification*: Primary 57R25; Secondary 55S40; 57R19; 57R20.

Keywords and phrases: vector field problem; projective Stiefel manifold; span; characteristic class; cohomology operation.

$M \rightarrow \mathbb{R}^p$. In addition to this, as proved by O. Saeki ([29]), if $q - p$ is even and there exists a fold map $M \rightarrow \mathbb{R}^p$, then $\text{span}^0(M) \geq p - 1$.

Stably parallelizable manifolds (known also as π -manifolds) are those for which the stable span is the same as the dimension; the Bredon-Kosinski theorem ([10]) effectively determines the span of such manifolds. The projective Stiefel manifolds $X_{n,r}$, $1 \leq r < n$, obtained from the ordinary Stiefel manifolds $V_{n,r}$ of orthonormal r -frames in \mathbb{R}^n by identifying $(v_1, \dots, v_r) \in V_{n,r}$ with $(-v_1, \dots, -v_r)$, form a family of closed, connected, smooth manifolds, among which relatively few are stably parallelizable (see [5]). Note that $X_{n,1} = P^{n-1}$, $(n - 1)$ -dimensional real projective space, for which the span question was solved by Adams [1]. The study of $X_{n,r}$ for $r > 1$ was inaugurated by P. Baum and W. Browder [8] and S. Gitler and D. Handel [11] in the 1960's, and has been a subject of ongoing interest since then ([4], [5], [6], [7], [31], [32], [35], [36] etc.).

This paper (mentioned as a "later paper" in [31]), in combination with [31], is an attempt to present the current state of knowledge concerning the span question for the projective Stiefel manifolds $X_{n,r}$, $r \geq 2$. This question is related to the same problem for other important spaces. For instance, for the flag manifold $O(n)/((O(1))^r \times O(n - r))$ we have that $\text{span}(X_{n,r}) \geq \text{span}(O(n)/((O(1))^r \times O(n - r)))$. We note that the information available on the span of the above mentioned flag manifold is in general quite weak (see [18]; an exception: for $r = 2$, quite a bit is known; see [3], [12], [15]).

In the sequel, the number $\dim(X_{n,r}) = nr - \binom{r+1}{2}$ will be denoted by $d_{n,r}$; we shall write just d instead of $d_{n,r}$ when (n, r) is clear from the context. For the tangent bundle we have ([22], [38])

$$(1.2) \quad \tau_{n,r} := TX_{n,r} \approx r\xi_{n,r} \otimes \beta_{n,r} \oplus \binom{r}{2} \varepsilon,$$

and stably

$$(1.3) \quad \tau_{n,r} \oplus \binom{r+1}{2} \varepsilon \approx nr\xi_{n,r},$$

where $\xi_{n,r}$ (sometimes denoted just by ξ) is the line bundle associated to the obvious double covering $V_{n,r} \rightarrow X_{n,r}$, and $\beta_{n,r}$ is the "orthogonal complement" bundle characterized by $r\xi_{n,r} \oplus \beta_{n,r} \approx n\varepsilon$. Note that $\xi_{n,1} = \xi_{n-1}$, the familiar Hopf line bundle over $X_{n,1} = P^{n-1}$.

Of course, $(\text{stable})\text{span}(X_{n,r})$ can be at least i only if the Stiefel-Whitney classes $w_{d-i+j}(\tau_{n,r}) := w_{d-i+j}(X_{n,r})$, $j \geq 1$, vanish. The isomorphism (1.3) implies that

$$(1.4) \quad w(X_{n,r}) = (1 + w_1(\xi_{n,r}))^{nr}.$$

For deciding whether or not $w_i(X_{n,r})$ vanishes, it is also necessary to know the \mathbb{Z}_2 -cohomology ring of $X_{n,r}$. By [11], 1.6;

$$(1.5) \quad H^*(X_{n,r}; \mathbb{Z}_2) = \mathbb{Z}_2[y]/(y^N) \otimes V(y_{n-r}, \dots, \hat{y}_{N-1}, \dots, y_{n-1}),$$

where $y = w_1(\xi_{n,r})$, $N = \min\{j; j \geq n - r + 1, \binom{n}{j} \equiv 1 \pmod{2}\}$, and

$$V(y_{n-r}, \dots, \hat{y}_{N-1}, \dots, y_{n-1})$$

is the \mathbb{Z}_2 -vector space having the monomials $\prod_{i=n-r}^{n-1} y_i^{t_i}$ with $i \neq N - 1$ and $t_i \in \{0, 1\}$ as \mathbb{Z}_2 -basis. For later use, we note that (1.5) immediately implies the formula for the mod 2 Poincaré polynomial:

$$P_t(X_{n,r}; \mathbb{Z}_2) = \frac{(1 + t + \dots + t^{N-1})(1 + t^{n-r}) \dots (1 + t^{n-1})}{1 + t^{N-1}}.$$

Additionally, (1.5) determines all cup products in $H^*(X_{n,r}; \mathbb{Z}_2)$ except for y_i^2 , which can be found using [4] since $y_i^2 = \text{sq}^i(y_i)$. Correcting misprints of [4], we reproduce the formulae for Steenrod squares here (these formulae were also published in [39]). Let $t := \nu_2(N)$ denote the exponent of the largest power of 2 dividing N . Then one has

$$\text{sq}^i(y_{q-1}) = \sum_{k=0}^i A_k y^k y_{q+i-1-k} + \sum_{0 \leq k < j \leq i} B_{k,j} y^{q+k+i-N-j} y_{N+j-k-1} + \epsilon y^{q+i-1},$$

where

$$\epsilon = \begin{cases} \binom{n}{q+2^{t-1}-N} \binom{q+2^t-1-N}{i-1} & \text{if } t \geq 3, \\ 0 & \text{if } t < 3, \end{cases}$$

$$A_k = A(q, i, k) = \binom{q-1-k}{q-1-i} \binom{n}{k},$$

$$B_{k,j} = B(q, i, k, j) = \binom{n}{q} \binom{N-1-k}{N-1-j} \binom{q-N}{i-j} \binom{n}{k}.$$

Apart from $X_{12,8}$, the parallelizability question for $X_{n,r}$, $r \geq 2$, is settled in [5] and in [6]. In addition to this, a complete solution to the vector field problem on $X_{n,r}$ is known for some families of (n, r) . More precisely, for $X_{n,1} = P^{n-1}$, one has, as a consequence of the solution of the vector field problem for spheres [1], that $\text{span}(X_{n,1}) = \text{span}(S^{n-1}) = \rho(n) - 1$, where $\rho(n) = 2^c + 8d$ for n expressed as $(2a + 1)2^{c+4d}$, $a, d \geq 0$, $0 \leq c \leq 3$. One calls $\rho(n)$ the Hurwitz-Radon number of n , and this will also be useful later in this work. At one extreme, for r close to n , it has long been known ([5]) that $X_{n,n-1}$ and $X_{2m,2m-2}$ (with m arbitrary) are parallelizable. Around 1998, Zvengrowski [39] has determined $\text{span}(X_{2m+1,2m-1})$ and $\text{span}(X_{n,n-3})$; thus $\text{span}(X_{n,n-j})$ is also known for $j \leq 3$. Our aim in this paper is to study the other extreme, r close to 2, and calculate the span of $X_{n,r}$ for some families with $r = 2, 3, 4$, as well as to prove some general results on $\text{span}(X_{n,r})$.

From the formula (1.2), one immediately has that $\text{span}(X_{n,r}) \geq 1$ when $r \geq 2$. In [18] and [19] we derived the strong lower bound

$$(1.6) \quad \text{span}^0(X_{n,r}) \geq k_{n,r}$$

for $\text{span}^0(X_{n,r})$, where $k_{n,r}$ is defined as follows:

Definition (1.7). $k_{n,r} := \text{span}(nr\xi_{n-1}) - \binom{r+1}{2}$.

Note that we always have $k_{n,r} \geq d_{n,r} - n + 1$, since $\text{span}(nr\xi_{n-1}) \geq nr - (n - 1)$ by standard stability properties of vector bundles. Since $d_{n,r}$ is in general much larger than $n - 1$, this shows that the resulting inequality $d_{n,r} - n + 1 \leq \text{span}^0(X_{n,r}) \leq d_{n,r}$ already gives relatively sharp estimates for $\text{span}^0(X_{n,r})$, which of course can be improved by applying cohomology theory to reduce the upper bound.

As was shown in [19], $k_{n,r}$ is in fact a lower bound for $\text{span}(X_{n,r})$ as well, except possibly when n is odd and $r = 2$. This seems to be the most intractable case and is studied in some detail in §2. We also prove Theorem 2.3 in §2, which improves the known lower bound for $\text{span}(X_{n-1,2})$ when n is divisible by 8. This involves using an explicit version of the Hurwitz-Radon multiplications, and an Appendix (§5) is added giving an elegant construction of these multiplications based on ideas of Moreno [27] and Lam-Yiu [23], [24].

Then in §3 we prove that if $2 \leq r \leq \rho(n)$, then

$$\text{span}(X_{n,r}) = \text{span}^0(X_{n,r}) = k_{n,r},$$

and we shall calculate $\text{span}(X_{n,r})$ for $r = 2, 3$ or 4 , for suitable (infinitely many) values of n , using the lower bound $k_{n,r}$ and other results.

In §4 we prove the following useful inequalities:

$$(1.8) \quad \begin{aligned} & \text{span}(X_{n,r+1}) \geq \text{span}(X_{n,r}), \\ & \text{and, for } s \geq 2, \text{span}(X_{n,r+s}) \geq \text{span}^0(X_{n,r}) + \binom{s}{2}. \end{aligned}$$

We close §4 with several conjectures about $\text{span}(X_{n,r})$, for which the results in this paper and its predecessors provide strong evidence.

2. On stable span and span of $X_{n,2}$

The projective Stiefel manifold $X_{n,2}$ has an interesting geometric interpretation, as the tangent sphere bundle to P^{n-1} ; but this fact will not be used here. Its dimension is of course $2n - 3$.

For $\text{span}^0(X_{n,2})$ we have the lower bound given in (1.6),

$$\text{span}^0(X_{n,2}) \geq k_{n,2} = \text{span}(2n\xi_{n,1}) - 3.$$

In fact, as mentioned in the Introduction, $k_{n,2}$ is known to also be a lower bound for $\text{span}(X_{n,2})$ when n is even. Indeed, the span and stable span of $X_{n,2}$ with n even coincide ([18], [19]), and we shall show, in §3, that $\text{span}(X_{n,2}) = k_{n,2}$ in such cases. Of course, determining $k_{n,r}$ (or in particular $k_{n,2}$) is a special case of the “generalized vector field problem” (this is the question of what is the span of any multiple of ξ_{n-1} over P^{n-1} , for any n). The latter is not yet completely known, but the results of Lam [21], Theorems 1.1, 3.1, Remark 3.5; and of Lam and Randall [25], 5.14; [26] give the answer in the majority of cases and imply the following proposition. The fact that the binomial coefficient $\binom{2m}{m}$ for $m \geq 1$ is even is implicitly used in those cases where no binomial coefficient is explicitly given; see also §3 for some further details and (in many cases) strengthened results.

PROPOSITION (2.1). *We have the following lower bounds.*

$$n = 8m \ \& \ m \geq 1 \ \& \ \binom{2m}{m-1} \text{ odd} \Rightarrow \text{span}(X_{n,2}) \geq k_{n,2} = n + 5.$$

$$n = 8m \ \& \ m \geq 2 \ \& \ \binom{2m}{m-1} \text{ even} \Rightarrow \text{span}(X_{n,2}) \geq k_{n,2} \geq n + 6, \\ \text{span}(X_{16,2}) \geq k_{16,2} = 23.$$

$$n = 8m + 1 \ \& \ m \geq 1 \Rightarrow \text{span}^0(X_{n,2}) \geq k_{n,2} \geq n,$$

$$\text{span}^0(X_{9,2}) \geq k_{9,2} = 13, \text{span}^0(X_{17,2}) \geq k_{17,2} \geq 22.$$

$$n = 8m + 2 \ \& \ m \geq 1 \Rightarrow \text{span}(X_{n,2}) \geq k_{n,2} \geq n + 2.$$

- $n = 8m + 3 \ \& \ m \geq 1 \Rightarrow \text{span}^0(X_{n,2}) \geq k_{n,2} \geq n + 1.$
- $n = 8m + 4 \ \& \ m \geq 0 \ \& \ \binom{2m+1}{m} \text{ odd} \Rightarrow \text{span}(X_{n,2}) \geq k_{n,2} = n + 1.$
- $n = 8m + 4 \ \& \ m \geq 2 \ \& \ \binom{2m+1}{m} \text{ even} \Rightarrow \text{span}(X_{n,2}) \geq k_{n,2} \geq n + 2.$
- $n = 8m + 5 \ \& \ m \geq 0 \ \& \ \binom{2m+1}{m} \text{ odd} \Rightarrow \text{span}^0(X_{n,2}) \geq k_{n,2} = n.$
- $n = 8m + 5 \ \& \ m \geq 2 \ \& \ \binom{2m+1}{m} \text{ even} \Rightarrow \text{span}^0(X_{n,2}) \geq k_{n,2} \geq n + 1.$
- $n = 8m + 6 \ \& \ m \geq 0 \ \& \ \binom{2m+1}{m} \text{ odd} \Rightarrow \text{span}(X_{n,2}) \geq k_{n,2} = n - 1.$
- $n = 8m + 6 \ \& \ m \geq 2 \ \& \ \binom{2m+1}{m} \text{ even} \Rightarrow \text{span}(X_{n,2}) \geq k_{n,2} \geq n + 3.$
- $n = 8m + 7 \ \& \ m \geq 0 \ \& \ \binom{2m+1}{m} \text{ odd} \Rightarrow \text{span}^0(X_{n,2}) \geq k_{n,2} = n - 2.$
- $n = 8m + 7 \ \& \ m \geq 2 \ \& \ \binom{2m+1}{m} \text{ even} \Rightarrow \text{span}^0(X_{n,2}) \geq k_{n,2} \geq n + 2. \quad \square$

By a special case of [14], Theorem 1.6; there are one or two isomorphism-classes of $d_{n,2}$ -plane bundles over $X_{n,2}$ which are stably isomorphic to the tangent bundle $\tau_{n,2}$; in other words, the James-Thomas number $I(X_{n,2})$ is 1 or 2, respectively. Clearly, $\text{span}^0(X_{n,2}) = \text{span}(X_{n,2})$ if $I(X_{n,2}) = 1$. But, as we shall see in Theorem (2.6), the equality $I(X_{n,2}) = 1$ is a rare phenomenon. In a remark after the proof of Theorem (2.6), we shall outline an idea which *perhaps* can lead to solving the question of whether or not $\text{span}^0(X_{n,2}) = \text{span}(X_{n,2})$ if $I(X_{n,2}) = 2$ and n is odd; but we did not succeed in applying this idea up to now. In view of this, since for n odd Proposition (2.1) gives lower bounds for $\text{span}^0(X_{n,2})$, but not for $\text{span}(X_{n,2})$, the following theorem is useful.

THEOREM (2.2). *For the projective Stiefel manifolds $X_{n,2}$ with $n \geq 7$ odd one has $\text{span}(X_{n,2}) \geq 4$. In addition to this, one has $\text{span}(X_{3,2}) = 3$ and $\text{span}(X_{5,2}) = 5$.*

Proof. Suppose that $n \geq 7$ is odd. Then $d_{n,2} = 2n - 3 \equiv 3 \pmod{4}$; since $n \geq 7$, we have $d_{n,2} \geq 11$. It is clear, for instance from the formula (1.4), that each of the manifolds $X_{n,2}$ is orientable. So by [20], 15.13; in order to prove $\text{span}(X_{n,2}) \geq 4$, it is enough to verify that now $w_2^2(X_{n,2})$ does not vanish, while $w_{d-3}(X_{n,2}) = 0$.

From the formula (1.4) we obtain $w_2^2(X_{n,2}) = y^4$, and this is not zero (see the description of $H^*(X_{n,r}; \mathbb{Z}_2)$ in the Introduction), because $N = n - 1 > 4$. In addition to this, $w_{d-3}(X_{n,2}) = \binom{2n}{6} y^{2n-6} = 0$, because we obviously have $2n - 6 > N$. So the theorem is proved for all $n \geq 7$ odd.

Consider the two remaining spaces. Since any orientable 3-dimensional manifold is parallelizable ([34]), span of $X_{3,2}$ is 3. Finally, from Proposition (2.1) we have that $\text{span}^0(X_{5,2}) \geq 5$. But, since $d_{5,2} = 7$, the James-Thomas number of this manifold is 1 (see [14], Theorem 1.7), and therefore its stable span and span coincide. So we also have $\text{span}(X_{5,2}) \geq 5$. On the other hand, $\text{span}(X_{5,2}) \geq 6$ is impossible; indeed, we have $w_2(X_{5,2}) = y^2 \neq 0$. As a consequence, $\text{span}(X_{5,2}) = 5. \quad \square$

Before proving the next theorem, which improves to $\text{span}(S^{n-1})$ the lower bound of 4 (given in Theorem (2.2)) for $\text{span}(X_{n-1,2})$ whenever $n \equiv 0 \pmod{8}$, some notation needs to be set up. For $r = \rho(n)$, let e_0, e_1, \dots, e_{r-1} be the canonical orthonormal basis in \mathbb{R}^r and $\varepsilon_0, \dots, \varepsilon_{n-1}$ be the canonical orthonormal basis in \mathbb{R}^n ; \mathbb{R}^{n-1} will be the subspace spanned by $\varepsilon_1, \dots, \varepsilon_{n-1}$. For any vector $c \in \mathbb{R}^n$

we shall write c' for its projection into \mathbb{R}^{n-1} . Thus, if $c = (c_0, \dots, c_{n-1})$, then $c' = (0, c_1, \dots, c_{n-1}) = c - c_0\varepsilon_0$.

Now let $\mathbb{R}^r \otimes_{\mathbb{R}} \mathbb{R}^n \rightarrow \mathbb{R}^n$ be a norm preserving multiplication, denoted $u \otimes v \mapsto u \cdot v := \phi_u(v)$, where $\phi_u \in O(n)$ whenever $\|u\| = 1$. In particular we write $\phi_i(v) = e_i \cdot v$, $0 \leq i \leq r-1$, and by replacing ϕ_i by $\phi_0^{-1} \circ \phi_i$ (which has no effect on the norm preserving property), we may suppose without loss of generality that $\phi_0 = I$. Construction of such norm preserving forms is carried out via [23], [24], [37], and briefly described in the appendix to this paper. As is shown there, it enjoys the following additional properties, of which (ii) is classical and (iii) describes the first coordinate of $\phi_j(a)$:

P(i): $e_0 \cdot v = v$, i.e. $\phi_0 = I$,

P(ii): for $i, j > 0$, $i \neq j$, $\phi_i^2 = -I$, $\phi_i\phi_j + \phi_j\phi_i = 0$,

P(iii): for $j \geq 1$, $a = (a_0, \dots, a_{n-1}) \in \mathbb{R}^n$, $e_j \cdot a - (e_j \cdot a)' = \pm a_{J(j)}\varepsilon_0$,

where the map $J: \{1, \dots, r-1\} \mapsto \{1, \dots, n-1\}$ is injective.

Since, for $i \geq 1$, the orthogonal skew symmetric transformation ϕ_i can be replaced by $-\phi_i$ with no effect on the norm preserving property, we may assume in P(iii) that $e_j \cdot a - (e_j \cdot a)' = -a_{J(j)}\varepsilon_0$, $j \geq 1$.

THEOREM (2.3). *One has $\text{span}(X_{n-1,2}) \geq \text{span}(S^{n-1})$.*

Proof. For $(a, b) \in V_{n-1,2}$, i.e. $a, b \in \mathbb{R}^{n-1}$, $\|a\| = \|b\| = 1$, $\langle a, b \rangle = 0$, define $w_j(a, b) = ((e_j \cdot a)', (e_j \cdot b)') \in \mathbb{R}^{n-1} \oplus \mathbb{R}^{n-1}$, $1 \leq j \leq r-1$.

First we show $w_j(a, b)$ is a tangent vector to $V_{n-1,2}$ at (a, b) . We use the explicit description of the tangent bundles to $V_{n,r}$ and $X_{n,r}$ given in [5], Lemma 2.2 (also in [38]). Let $v = (a, b)$ denote a point of the Stiefel manifold $V_{n-1,2}$, and let $[v] = \{v, -v\}$ be the corresponding point in the projective Stiefel manifold $X_{n-1,2}$. Then the tangent space $T_{[v]}(X_{n-1,2})$ consists of pairs $[v, w]$, where $w = (x, y)$ with $x, y \in \mathbb{R}^{n-1}$ is such that

$$\langle a, x \rangle = \langle b, y \rangle = \langle a, y \rangle + \langle b, x \rangle = 0, [v, w] = [-v, -w].$$

The tangent space $T_v(V_{n-1,2})$ is similar (without identifications).

Noting that $\langle x, y' \rangle = \langle x, y \rangle$ whenever $x \in \mathbb{R}^{n-1}$, $y \in \mathbb{R}^n$, we then have $\langle a, (e_j \cdot a)' \rangle = \langle a, e_j \cdot a \rangle = 0$, similarly for b , and finally

$$\langle a, (e_j \cdot b)' \rangle + \langle b, (e_j \cdot a)' \rangle = \langle a, e_j \cdot b \rangle + \langle b, e_j \cdot a \rangle = \langle a, e_j \cdot b \rangle + \langle -e_j \cdot b, a \rangle = 0.$$

Second, since $w_j(-a, -b) = -w_j(a, b)$, the w_j induce well defined vector fields on $X_{n-1,2}$.

Finally, let us show that $w_1(a, b), \dots, w_{r-1}(a, b)$ are linearly independent. So suppose $\sum_{j=1}^{r-1} \lambda_j w_j(a, b) = 0$, with not all λ_j zero. Write $\lambda = \sum_{j=1}^{r-1} \lambda_j \varepsilon_j \in \mathbb{R}^{n-1}$. We also write, for later use, $\tilde{\lambda} = \sum_{j=1}^{r-1} \lambda_j \varepsilon_j \in \mathbb{R}^r$. Without loss of generality assume $\|\lambda\| = 1$, so also $\|\tilde{\lambda}\| = 1$. By definition $\sum_{j=1}^{r-1} \lambda_j (e_j \cdot a)' = \sum_{j=1}^{r-1} \lambda_j (e_j \cdot b)' = 0$. Working with a , and using the equation for c' as well as the property of $e_j \cdot a$ mentioned above, this gives $\sum_{j=1}^{r-1} \lambda_j (e_j \cdot a + a_{J(j)}\varepsilon_0) = 0$, where we now write $J = J(j)$ for convenience. Thus

$$(2.4) \quad \sum_{j=1}^{r-1} \lambda_j e_j \cdot a = -\left(\sum_{j=1}^{r-1} \lambda_j a_{J(j)}\right)\varepsilon_0.$$

Trivially, $|\langle \lambda, \sum_{j=1}^{r-1} a_j \varepsilon_j \rangle| = |\sum_{j=1}^{r-1} \lambda_j a_j| = \| -\sum_{j=1}^{r-1} (\lambda_j a_j) \varepsilon_0 \|$. Now, applying successively (2.4) followed by the norm preserving property, this equals $\| \sum_{j=1}^{r-1} (\lambda_j e_j) \cdot a \| = \| \tilde{\lambda} \| \| a \| = 1 \cdot 1 = 1$. Since the inner product of two vectors, the first being a unit vector and the second having norm at most 1, can have absolute value 1 if and only if they are parallel and the second has norm 1, we have then that $\lambda = \pm \sum_{j=1}^{r-1} a_j \varepsilon_j$. Exactly the same applies to b , so $\lambda = \pm \sum_{j=1}^{r-1} b_j \varepsilon_j$. Finally, since $J = J(j)$ is injective by P(iii), this implies that a, b are also parallel, giving the desired contradiction and completing the proof. \square

COROLLARY (2.5). *We have $\text{span}(X_{7,2}) = 7$.*

Proof. The lower bound 7 is obtained from the theorem, and Stiefel-Whitney classes easily give the same upper bound. \square

Our next theorem shows that the manifolds $X_{n,2}$ mostly have James-Thomas number 2.

THEOREM (2.6). *While the James-Thomas number is 1 for $X_{3,2}$ and $X_{5,2}$, it equals 2 for the remaining projective Stiefel manifolds $X_{n,2}$, except possibly for $n = 2^t + 1, t \geq 3$.*

Proof. In the proof, we shall suppose $n \neq 2^t + 1$. Let BO be the classifying space of the stable orthogonal group O , and let

$$\sigma: H^{i+1}(BO; \mathbb{Z}_2) \longrightarrow H^i(\Omega BO; \mathbb{Z}_2)$$

be the suspension homomorphism. In applying [14], Theorem 1.6; we shall replace the loop space ΩBO by O (see e.g. [2], 2.3.1 (iv)). Then instead of $\sigma(w_{i+1})$, where w_j is the j -th universal Stiefel-Whitney class, we shall for convenience write $v_i \in H^i(O; \mathbb{Z}_2), i \geq 1$. Now, by [14], it suffices to show that for any map $\beta: X_{n,2} \longrightarrow O$ one has

$$\Delta(\beta) := \beta^*(v_{2n-3}) + \sum_{i=2}^{2n-3} \beta^*(v_{i-1}) w_{2n-2-i}(X_{n,2}) = 0 \in H^{2n-3}(X_{n,2}; \mathbb{Z}_2).$$

We have (see (1.5))

$$(2.7) \quad H^*(X_{n,2}; \mathbb{Z}_2) = \mathbb{Z}_2[y]/(y^N) \otimes V(y_q),$$

as an algebra, where $N = n - 1, n$ according as n is respectively odd, even, and $q = n - 1, n - 2$ according as n is respectively odd, even (note q is thus always even). Since (1.4) implies

$$w_{2n-2-i}(X_{n,2}) = \binom{2n}{2n-2-i} y^{2n-2-i},$$

we have

$$\Delta(\beta) = \beta^*(v_{2n-3}) + \sum_{i=2}^{2n-3} \beta^*(v_{i-1}) \binom{2n}{2+i} y^{2n-2-i}.$$

To show this is 0 it will certainly suffice, since $y^{2n-3} = 0$, to prove that $\beta^*(v_j) \in \mathbb{Z}_2[y]/(y^N)$, $j \geq 1$. Now we recall that by [9], (8.7); one has for the Steenrod squares

$$Sq^i(v_j) = \binom{j}{i} v_{i+j}$$

for $i \leq j$. Hence it is sufficient to show that

$$\beta^*(v_{2^k-1}) \in \mathbb{Z}_2[y]/(y^N), \quad k \geq 1.$$

This task is trivial if $2^k - 1 < q$, so one only has to consider the range for k where $2^k - 1 \geq q$. Then one has

$$(2.8) \quad \beta^*(v_{2^k-1}) = \lambda y_q y^{2^k-1-q}$$

for some $\lambda \in \mathbb{Z}_2$. Using [4], 2.1 (see the Introduction), one readily checks that $Sq^1(y_q) = 0$, and applying Sq^1 to (2.8), we obtain

$$(2.9) \quad \lambda y_q y^{2^k-q} = \beta^*(v_{2^k}).$$

Observe that the top class in $H^*(X_{n,2}; \mathbb{Z}_2)$ is $y_q y^{n-2}$ if n is odd or $y_q y^{n-1}$ if n is even. Hence in all the cases which we need to consider we have $2^k - q < N$; therefore $y_q y^{2^k-q} \neq 0$. On the other hand,

$$\beta^*(v_{2^k}) \in \mathbb{Z}_2[y]/(y^N),$$

because

$$v_{2^k} = Sq^{2^{k-1}} \dots Sq^2 Sq^1(v_1).$$

Finally, since $2^k \geq q + 2 \geq N$, we have $\beta^*(v_{2^k}) = 0$ and (2.9) implies that $\lambda = 0$. □

We remark that for $X_{2^t+1,2}$ ($t \geq 3$) the problem of determining James-Thomas numbers remains open. To close this section, we outline (as we promised before the statement of Theorem (2.2) a possible way of thinking (in the spirit of [18], p. 8-9) about the relation between stable span and span of any odd-dimensional smooth closed manifold M with $I(M) = 2$, in particular for $M = X_{n,2}$ when n is odd and $I(X_{n,2}) = 2$. In this case, for any $d_{n,2}$ -plane bundle α stably isomorphic to $\tau_{n,2}$ one has (see [33]) a number $b_B(\alpha) \in \mathbb{Z}_2$, called the Browder-Dupont invariant. This b_B distinguishes between those two classes of $d_{n,2}$ -plane bundles stably isomorphic to $\tau_{n,2}$, and $b_B(\tau_{n,2})$ is precisely the Kervaire mod 2 semi-characteristic

$$(2.10) \quad \chi_2(X_{n,2}) = \sum_{i=0}^{n-2} \dim(H^i(X_{n,2}; \mathbb{Z}_2)) \pmod{2}.$$

Observe that for any odd-dimensional $X_{n,r}$, the Kervaire semi-characteristic is nothing but $\frac{1}{2}P_1(X_{n,r}; \mathbb{Z}_2) \pmod{2}$. From the formula for the Poincaré polynomial $P_t(X_{n,r}; \mathbb{Z}_2)$ it is easy to see that P_1 is divisible by 4 for $r \geq 2$; thus the Kervaire semi-characteristic vanishes in all such cases. Now suppose that we are given some $X_{n,2}$ with n odd and $I(X_{n,2}) = 2$ about which we know that $\text{span}^0(X_{n,2})$ is some number s ; then there is a vector bundle η such that $\tau_{n,2} \oplus \varepsilon \approx \eta \oplus (s + 1)\varepsilon$. Since, as we have seen, $b_B(\tau_{n,2}) = 0$, it is enough to be able to show that $b_B(\eta \oplus s\varepsilon) = 0$ in order to conclude that $\tau_{n,2} \approx \eta \oplus s\varepsilon$, and $\text{span}(X_{n,2}) = s = \text{span}^0(X_{n,2})$. One can try to proceed analogously knowing

that $\text{span}^0(X_{n,2}) \geq k$ for some k (for instance $k = k_{n,2}$), when one wants to show that also $\text{span}(X_{n,2}) \geq k$.

3. The span of $X_{n,r}$ for $r \leq \rho(n)$ and for $r \leq 4$

The following theorem and its corollary allow us to calculate the stable span and also the span of those projective Stiefel manifolds $X_{n,r}$ satisfying $r \leq \rho(n)$, at least to within the knowledge of $k_{n,r}$.

THEOREM (3.1). *If $r \leq \rho(n)$, then we have $\text{span}^0(X_{n,r}) = k_{n,r}$.*

Proof. If $r \leq \rho(n)$, then (as shown in the Appendix) there exists a \mathbb{Z}_2 -equivariant (indeed linear) cross section of the fibre bundle $V_{n,r} \rightarrow V_{n,1} = S^{n-1}$. This therefore induces a cross section s of the fibre bundle $\pi: X_{n,r} \rightarrow X_{n,1} = P^{n-1}$ such that $s^*(\xi_{n,r}) \approx \xi_{n,1}$. Since also $\pi^*(\xi_{n,1}) \approx \xi_{n,r}$, it follows that $\text{span}(m\xi_{n,r}) = \text{span}(m\xi_{n,1})$ for any m . This yields (see (1.3) and Definition (1.7))

$$\text{span}^0(X_{n,r}) = \text{span}(nr\xi_{n,r}) - \binom{r+1}{2} = \text{span}(nr\xi_{n,1}) - \binom{r+1}{2} = k_{n,r} .$$

□

COROLLARY (3.2). *If $2 \leq r \leq \rho(n)$ then we have $\text{span}(X_{n,r}) = k_{n,r}$.*

Proof. The hypotheses imply n is even. Then, as a special case of [19], Theorem p. 100; $\text{span}(X_{n,r}) \geq k_{n,r}$. Theorem (3.1) therefore implies now that $\text{span}(X_{n,r}) \geq \text{span}^0(X_{n,r})$, and, as a consequence, $\text{span}(X_{n,r}) = \text{span}^0(X_{n,r})$. □

We next calculate the span for several infinite families of projective Stiefel manifolds $X_{n,r}$ with $2 \leq r \leq 4$; we shall use various methods for showing, in each case under question, that the lower and upper bounds coincide. For cases (a)-(d), which are strengthenings of results in Proposition (2.1), the following special binomial coefficients are used. All follow readily from Kummer’s formula

$$\nu_2 \binom{s+t}{t} = \alpha(s) + \alpha(t) - \alpha(s+t),$$

where ν_2 was defined in §1 and $\alpha(t)$ is the number of 1’s in the dyadic expansion of t .

$$\nu_2 \binom{2m}{m} = \alpha(m) \begin{cases} = 1, & m = 2^a, a \geq 0, \\ \geq 2, & \text{otherwise,} \end{cases}$$

$$\nu_2 \binom{2m+1}{m} = \alpha(m+1) - 1 \begin{cases} = 0, & m = 2^a - 1, a \geq 0, \\ = 1, & m = 2^a + 2^b - 1, 0 \leq a < b, \\ \geq 2, & \text{otherwise,} \end{cases}$$

$$\nu_2 \binom{2m}{m-1} = \alpha(m-1) + \alpha(m+1) - \alpha(m) \begin{cases} = 0, & m = 2^a - 1, a > 0, \\ = 1, & m = 2^a + 2^b - 1, 0 < a < b, \\ \geq 2, & \text{otherwise.} \end{cases}$$

THEOREM (3.3). *We have that $\text{span}(X_{2t,2}) = k_{2t,2}$, in particular:*

(a) *If $n = 8m$, then $\text{span}(X_{n,2}) = n + 5$ for $m = 2^a - 1$, i.e. $n = 2^{a+3} - 8$ ($a > 0$). Also $\text{span}(X_{16,2}) = 23$.*

(b) *If $n = 8m + 2$, then $\text{span}(X_{n,2}) = n + 2$ for $m = 2^a$, i.e. $n = 2^{a+3} + 2$ ($a \geq 0$).*

(c) *If $n = 8m + 4$, then $\text{span}(X_{n,2}) = n + 1$ for $m = 2^a - 1$, i.e. $n = 2^{a+3} - 4$ ($a \geq 0$), and $\text{span}(X_{n,2}) = n + 2$ for $m = 2^a + 2^b - 1$, i.e. $n = 2^{a+3} + 2^{b+3} - 4$ ($0 \leq a < b$).*

(d) *If $n = 8m + 6$, then $\text{span}(X_{n,2}) = n - 1$ for $m = 2^a - 1$, i.e. $n = 2^{a+3} - 2$ ($a \geq 0$), and $\text{span}(X_{n,2}) = n + 3$ for $m = 2^a + 2^b - 1$, i.e. $n = 2^{a+3} + 2^{b+3} - 2$ ($0 \leq a < b$).*

In addition, we have:

(e) *For $m \geq 3$, $\text{span}(X_{2^m-2,3}) = 2^{m+1} - 6$.*

(f) *For $m \geq 2$, $\text{span}(X_{2^m+1,3}) = 2^{m+1} - 3$.*

(g) *For $m \geq 3$, $\text{span}(X_{2^m-2,4}) = 3 \cdot 2^m - 10$.*

Proof. The fact that $\text{span}(X_{2t,2}) = k_{2t,2}$ is an immediate consequence of Corollary (3.2), and (a)-(d) are then clear from Proposition (2.1) together with the above formulae for binomial coefficients.

(e) and (g) From [21], Theorem 1.1; combined with [19], Theorem, p. 100; (note that for $X_{n,3}$ we could derive a result similar to Proposition (2.1), we obtain that $\text{span}(X_{2^m-2,3}) \geq 2^{m+1} - 6 = k_{2^m-2,3}$. In addition to this, $k_{2^m-2,3}$ is an upper bound, too, because $w_{d-2^{m+1}+6}(X_{2^m-2,3}) = y^{2^m-6}$ does not vanish (note that now $N = 2^m - 4$). This proves (e); part (g) can be proved in an analogous way.

(f) Since $k_{2^m+1,3} = 3 \cdot 2^m + 3 - 2^m - 6 = 2^{m+1} - 3$, we have (applying again [19], Theorem, p. 100) that $\text{span}(X_{2^m+1,3}) \geq 2^{m+1} - 3$. Now $w_{d-2^{m+1}+3}(X_{2^m+1,3}) = 0$, so more delicate techniques are needed to show that $2^{m+1} - 3$ is also an upper bound for the span. Indeed, in this case both primary and secondary cohomology operations will be used.

We know (see e.g. [18]) that $\text{span}(X_{2^m+1,3}) \geq 2^{m+1} - 2$ would imply the existence of a map $f: X_{2^m+1,3} \rightarrow X_{3,2^m+3,2^{m+1}+4}$ such that $f^*(\xi) \approx \xi$. Hence, in cohomology, we would then have that $f^*(Y) = y$, where

$$H^*(X_{2^m+1,3}; \mathbb{Z}_2) = \mathbb{Z}_2[y]/(y^{2^m}) \otimes V(y_{2^m-2}, y_{2^m})$$

and

$$H^*(X_{3,2^m+3,2^{m+1}+4}; \mathbb{Z}_2) = \mathbb{Z}_2[Y]/(Y^{2^m}) \otimes V(Y_{2^m}, Y_{2^m+1}, Y_{2^m+2}, \dots, Y_{3,2^m+2}).$$

Using the squaring operations as given in §1, the following are easily calculated and will be recorded here for future use in this proof.

$$(3.4) \quad \text{sq}^1(Y_{2^m}) = 0, \text{sq}^1(y_{2^m}) = 0,$$

$$(3.5) \quad \text{sq}^1(y_{2^m-2}) = yy_{2^m-2},$$

$$(3.6) \quad \text{sq}^2(y_{2^m}) = y^2y_{2^m},$$

$$(3.7) \quad \text{sq}^2(Y_{2^m}) = 0.$$

To now show that such a map f cannot exist, we will use the Steenrod algebra \mathcal{A}_2 and also the secondary Bockstein cohomology operation β_2 corresponding to the relation $\text{sq}^1 \text{sq}^1 = 0$. We know (see [11]) that, up to homotopy type, there

is a Serre fibration $\pi: X_{n,r} \rightarrow P^\infty$, with fibre the Stiefel manifold $V_{n,r}$. Let $i: V_{n,r} \rightarrow X_{n,r}$ be fibre inclusion; recall that $H^*(V_{n,r}; \mathbb{Z}_2) = V(x_{n-r}, \dots, x_{n-1})$, and we have $i^*(y_j) = x_j$.

If ξ is the Hopf line bundle over P^∞ , one has $\pi^*(\xi) \approx \xi$; if we write $H^*(P^\infty; \mathbb{Z}_2) = \mathbb{Z}_2[x]$ with $x = w_1(\xi)$, the equivalent of $\pi^*(\xi) \approx \xi$ is $\pi^*(x) = y$.

In the Serre spectral sequence of the fibration $\pi: X_{2^m+1,3} \rightarrow P^\infty$, the element x_{2^m-1} is transgressive with $\tau(x_{2^m-1}) = \text{sq}^1(x_{2^m-1})$. It follows, by the third Peterson-Stein formula [28], Chap. 16, Theorem 3; and [4], that

$$i^*(\beta_2(\pi^*(x_{2^m-1}))) = \text{sq}^1(x_{2^m-1}) = x_{2^m},$$

modulo indeterminacy $i^*(\text{sq}^1(H^{2^m-1}(X_{2^m+1,3}; \mathbb{Z}_2)))$. In $H^{2^m-1}(X_{2^m+1,3}; \mathbb{Z}_2)$ we take $\{y^{2^m-1}, y y_{2^m-2}\}$ as basis. Now $\text{sq}^1(y^{2^m-1}) = y^{2^m} = 0$, also (3.5) and the Cartan formula imply $\text{sq}^1(y \cdot y_{2^m-2}) = y^2 \cdot y_{2^m-2} + y \cdot y y_{2^m-2} = 0$. Hence the indeterminacy vanishes, and we have

$$(3.8) \quad i^* \beta_2(y^{2^m-1}) = x_{2^m}$$

as an ‘‘honest equation’’.

Using the same reasoning in $X_{3 \cdot 2^m+3, 2^{m+1}+4}$, one finds similarly that

$$(3.9) \quad i^* \beta_2(Y^{2^m-1}) = x_{2^m},$$

again with zero indeterminacy.

It follows that $\beta_2(y^{2^m-1}) = a \cdot y^2 y_{2^m-2} + b \cdot y_{2^m}$, for some $a, b \in \mathbb{Z}_2$, and $\beta_2(Y^{2^m-1}) = c \cdot Y_{2^m}$, for some $c \in \mathbb{Z}_2$, both with zero indeterminacy. Noting that $i^*(y) = i^* \pi^*(x) = 0$, and using (3.8), the first equation gives

$$x_{2^m} = i^* \beta_2(y^{2^m-1}) = a \cdot i^*(y^2 y_{2^m-2}) + b \cdot i^*(y_{2^m}) = 0 + b \cdot x_{2^m},$$

and therefore $b = 1$. Similarly, using (3.9), one finds $c = 1$ and thus $\beta_2(Y^{2^m-1}) = Y_{2^m}$.

The naturality of β_2 is expressed by the equation

$$(3.10) \quad f^*(\beta_2(Y^{2^m-1})) = \beta_2(f^*(Y^{2^m-1})),$$

where the indeterminacy is

$$f^* \text{sq}^1(H^{2^m-2}(X_{3 \cdot 2^m+3, 2^{m+1}+4}; \mathbb{Z}_2)) + \text{sq}^1(H^{2^m-2}(X_{2^m+1,3}; \mathbb{Z}_2)) = 0,$$

as we have seen above. It follows that

$$f^*(Y_{2^m}) = f^*(\beta_2(Y^{2^m-1})) = \beta_2(f^*(Y^{2^m-1})) = \beta_2(y^{2^m-1}) = a \cdot y^2 y_{2^m-2} + y_{2^m}.$$

We show that $a = 0$. Indeed, we have $0 = f^*(0) = f^*(\text{sq}^1(Y_{2^m})) = \text{sq}^1(f^*(Y_{2^m})) = \text{sq}^1(y_{2^m}) + a \cdot \text{sq}^1(y^2 y_{2^m-2}) = a \cdot y^3 y_{2^m-2}$, the last equality following from (3.4), (3.5) and the Cartan formula, and thus $a = 0$.

So we have shown

$$f^*(Y_{2^m}) = y_{2^m}.$$

But this implies, using (3.6), that $\text{sq}^2(f^*(Y_{2^m})) = \text{sq}^2(y_{2^m}) = y^2 y_{2^m+1}$ does not vanish. On the other hand, using (3.7), the same element $f^*(\text{sq}^2(Y_{2^m})) = f^*(0)$ vanishes. Of course, this is a contradiction, and we have shown that $\text{span}(X_{2^m+1,3}) \leq 2^{m+1} - 3$ for $m \geq 2$. The proof of part (f), and of the whole Theorem (3.3), is complete. \square

We remark that the same techniques used above to compute the secondary Bockstein operation can be used to compute any secondary cohomology operation Φ of degree t on x^{N-t} , $x \in H^1(X_{n,r}; \mathbb{Z}_2)$, assuming of course x^{N-t} is in the domain of Φ .

4. Inequalities for the span and some conjectures

A useful piece of information on the span of projective Stiefel manifolds is also the following.

THEOREM (4.1). *One has $\text{span}(X_{n,r+1}) \geq \text{span}(X_{n,r})$, and, for $s \geq 2$,*

$$\text{span}(X_{n,r+s}) \geq \text{span}^0(X_{n,r}) + \binom{s}{2}.$$

Proof. The first assertion is an immediate consequence of the existence of a smooth fibration $p: X_{n,r+1} \rightarrow X_{n,r}$. For the second, using the notation of [19], note that vector bundle isomorphisms $\tau_{n,r+1} \approx p^* \tau_{n,r} \oplus \beta'_{n,r+1}$ ((iii) in [19], p. 98) and $p^* \beta'_{n,r} \approx \beta'_{n,r+1} \oplus \varepsilon$ ((ii) in [19], p. 98) describe the effect of the pull-back p^* on the tangent bundle $\tau_{n,r}$ and on the twisted orthogonal complement bundle $\beta'_{n,r} \approx \beta_{n,r} \otimes \xi_{n,r}$ ($\beta_{n,r}$ is described in §1). Iterating these isomorphisms s times, one easily establishes inductively, for the fibration $q: X_{n,r+s} \rightarrow X_{n,r}$, that

$$\tau_{n,r+s} \approx q^*(\tau_{n,r}) \oplus \binom{s}{2} \varepsilon \oplus s\beta'_{n,r+s}.$$

If $s \geq 2$ then the right hand side can be rewritten

$$q^*(\tau_{n,r} \oplus \varepsilon) \oplus \left(\binom{s}{2} - 1 \right) \varepsilon \oplus s\beta'_{n,r+s},$$

which has span at least as great as $(\text{span}^0(X_{n,r}) + 1) + (\binom{s}{2} - 1) = \text{span}^0(X_{n,r}) + \binom{s}{2}$, completing the proof. □

By saying that r is in the lower range of n we roughly mean that $r < n/2$; see [7] for precise information on the lower range. Based on the results of this paper, [17], and other predecessors we make the following conjectures.

- Conjectures (4.2).* (A) $\text{span}(X_{n,r}) \geq k_{n,r}$.
- (B) $\text{span}(X_{n,r}) = \text{span}^0(X_{n,r})$.
- (C) In the lower range, $\text{span}(X_{n,r}) = k_{n,r}$.

Remarks (4.3). (1) Conjecture (4.2)(A) is proved in [19] for all n, r except n odd, $r = 2$.

(2) Conjecture (4.2)(B) implies Conjecture (4.2)(A), and (B) is proved for roughly 70% of all (n, r) pairs using the results in [20], Ch. 20; see also [18], [19].

(3) Conjecture (4.2)(C) is supported by various results in the present paper, especially Corollary (3.2) and Theorem (3.3), and all other calculations to date. For $n \leq 18$ a small number of exceptions can and do occur, because the product rn can be divisible by $\phi(n-1)$ when $n \leq 18$; here as usual $\phi(n)$ is the number of integers j satisfying $1 \leq j \leq n$ and $j \equiv 0, 1, 2, 4 \pmod{8}$. In the upper range, it is usually the case that $\text{span}(X_{n,r}) > k_{n,r}$.

(4) All Conjectures (4.2)(A),(B),(C), are true when $r = 1$. This is trivial for (A), (C). For (B), when n is odd, it follows because the Euler characteristic $\chi(X_{n,1}) = \chi(\mathbb{R}P^{n-1}) = 1$ is odd. For n even it is proved in [14].

5. Appendix, Hurwitz-Radon Multiplications

In this appendix a construction of the Hurwitz-Radon multiplications

$$F: \mathbb{R}^r \otimes \mathbb{R}^n \rightarrow \mathbb{R}^n, \quad r = \rho(n),$$

is briefly outlined. As in §1, we write $n = (2a + 1)2^{c+4d}$, $a, d \geq 0$, $0 \leq c \leq 3$, and $\rho(n) = 2^c + 8d$. The method is that of Lam and Yiu [24], [23], uses Cayley-Dickson algebras (cf. Moreno [27]), and could be considered a shorter and more elegant version of [37]. The facts essential to the proof of Theorem (2.3 will also be established. These multiplications all have the norm-preserving property $\|F(u \otimes v)\| = \|u\| \cdot \|v\|$.

For details of the construction of the Cayley-Dickson algebra \mathbb{A}_n , of real dimension 2^n , we refer to [27]. To commence it suffices to recall that $\mathbb{A}_0 = \mathbb{R}$, $\mathbb{A}_1 = \mathbb{C}$, $\mathbb{A}_2 = \mathbb{H}$, $\mathbb{A}_3 = \mathbb{O}$ (respectively the reals, complex numbers, quaternions, and octonions), well known algebras with norm-preserving multiplications. The sedenions \mathbb{A}_4 will be discussed and applied in the following paragraph. The algebras \mathbb{A}_i , $0 \leq i \leq 3$, with multiplication denoted F , suffice to construct the Hurwitz-Radon multiplications for the case $d = 0$, i.e. $n = (2a + 1)2^c$, $0 \leq c \leq 3$ (note that then $r = \rho(n) = 2^c$) by means of the composition

$$\mathbb{R}^r \otimes \mathbb{R}^n = \mathbb{R}^r \otimes (\mathbb{R}^r \otimes \mathbb{R}^{2a+1}) \approx (\mathbb{R}^r \otimes \mathbb{R}^r) \otimes \mathbb{R}^{2a+1} \xrightarrow{F \otimes id} \mathbb{R}^r \otimes \mathbb{R}^{2a+1} = \mathbb{R}^n.$$

The corresponding orthogonal transformations $\phi_0, \phi_1, \dots, \phi_{r-1}$ (defined in §2) are well known to satisfy properties P(i), P(ii) stated in §2. They are also clearly given by signed permutation matrices with an equal number of plus and minus signs (apart from $\phi_0 = I_n$), since this is true for the multiplication F in \mathbb{A}_i . In addition, for $1 \leq i < j \leq r - 1$ let us write $v = (x_1, \dots, x_n) \in \mathbb{R}^n$, and $\phi_i(v) = (\pm x_{\sigma(1)}, \dots, \pm x_{\sigma(n)})$, $\phi_j(v) = (\pm x_{\tau(1)}, \dots, \pm x_{\tau(n)})$ for some permutations σ, τ , and some choice of signs. Since $\phi_i(v) \perp \phi_j(v)$, it is clear that $\sigma(k) \neq \tau(k)$, $1 \leq k \leq n$, giving (by taking $k = 1$) property P(iii). This completes the case $d = 0$.

The Lam-Yiu construction, for $d > 0$, gives an inductive procedure such that replacing n by $16n$ will increase r to $r + 8$, this being precisely what the Hurwitz-Radon formula asserts. To this end we turn to the sedenions \mathbb{A}_4 . According to the Cayley-Dickson construction they consist of ordered pairs (u, v) , where $u, v \in \mathbb{O}$, added coordinate-wise and multiplied by the rule $(u, v)(x, y) = (ux - \bar{y}v, yu + v\bar{x})$. Unlike the norm-preserving multiplication in \mathbb{A}_j , $j = 0, 1, 2, 3$, \mathbb{A}_4 has divisors of zero. However, restricting the multiplication of \mathbb{A}_4 to $\mathbb{R}^9 \otimes \mathbb{R}^{16} \rightarrow \mathbb{R}^{16}$, where $\mathbb{R}^9 = \mathbb{R}^{\rho(16)}$ is taken to be the subspace

$$\{(a_0, a_1, a_2, a_3, a_4, a_5, a_6, a_7, a_8, 0, 0, 0, 0, 0, 0, 0, 0); a_i \in \mathbb{R}, i = 0, \dots, 8\},$$

it is easy to show that this restricted multiplication is norm-preserving. We denote it Φ , and it can also be found written in tabular form in [13], p. 4. Taking the standard basis e_0, e_1, \dots, e_8 for \mathbb{R}^9 , one defines orthogonal transformations $\gamma_i \in O(16)$, $0 \leq i \leq 8$, by $\gamma_i(v) = \Phi(e_i \otimes v)$. As usual $\gamma_0 = I$, and for

$1 \leq i, j \leq 8$, γ_i is skew symmetric, $\gamma_i^2 = -I$, and $\gamma_i\gamma_j + \gamma_j\gamma_i = 0$, $i \neq j$, it is also standard that these properties are equivalent to the multiplication being norm-preserving. In addition it is clear, using the definition or the table in [13], that each γ_i , $i > 0$, is a signed permutation matrix with an equal number of plus and minus signs.

To effect the Lam-Yiu construction, one also defines $\Gamma = \gamma_1 \cdots \gamma_8$. One can easily verify that Γ is symmetric, $\Gamma^2 = I$, and for $i > 0$ one has $\Gamma\gamma_i + \gamma_i\Gamma = 0$. Being a product of signed permutation matrices it must also be a signed permutation matrix, indeed, it is easy to check that for $x = (x_1, \dots, x_{16})$, $\Gamma(x) = (-x_9, x_{10}, x_{11}, \dots, x_{16}, -x_1, x_2, x_3, \dots, x_8)$.

Now suppose one has a norm-preserving multiplication $F: \mathbb{R}^r \otimes \mathbb{R}^n \rightarrow \mathbb{R}^n$, then just as for Φ one defines $r = \rho(n)$ orthogonal transformations $\theta_0, \dots, \theta_{r-1} \in O(n)$. As in §2 (just before P(i)-P(iii)), we may suppose that $\theta_0 = I$. Then the remaining θ_i , $1 \leq i \leq r-1$, are skew symmetric and satisfy the same identities as the γ_i above. In addition, we assume (inductively) that they are signed permutation matrices. Then we construct a norm-preserving multiplication $G: \mathbb{R}^{\rho(n)+8} \otimes \mathbb{R}^{16n} \rightarrow \mathbb{R}^{16n} \approx \mathbb{R}^n \otimes \mathbb{R}^{16}$ by defining the corresponding $\rho(n) + 8 = \rho(16n)$ orthogonal transformations in $O(16n)$ as

$$\begin{aligned}\phi_0 &= I, \quad \phi_1 = \theta_1 \otimes \Gamma, \quad \dots, \quad \phi_{\rho(n)-1} = \theta_{\rho(n)-1} \otimes \Gamma, \\ \phi_{\rho(n)} &= I \otimes \gamma_1, \quad \dots, \quad \phi_{\rho(n)+7} = I \otimes \gamma_8.\end{aligned}$$

One easily checks that the ϕ_i satisfy the same identities as the γ_i , θ_i , and hence define a norm-preserving multiplication on \mathbb{R}^{16n} . Furthermore, the tensor product of signed permutation matrices is obviously again a signed permutation matrix. Starting from the already completed case $d = 0$, this construction inductively produces the Hurwitz-Radon multiplications, as a family of skew symmetric signed permutation matrices (and the first being I). This establishes properties P(i), P(ii) used in the proof of Theorem (2.3), and an argument similar to that used above in the $d = 0$ case, also gives property P(iii).

The fact established above, that the Hurwitz-Radon multiplications are given by signed permutation matrices, is also of interest in the combinatorial study of Hadamard matrices. Although this fact is likely known, perhaps even since the time of Hurwitz and Radon, to the best of the authors' knowledge it (or its proof) does not appear in the literature.

Acknowledgments

The authors thank the referees for their helpful comments leading to an improved presentation. Part of this research was carried out while J. Korbaš was a member of two research teams supported in part by the grant agency VEGA and a member of two bilateral (Slovak-Czech 0081-07 and Slovak-Slovenian 0005-08) teams supported in part by the grant agency APVV.

Received November 3, 2008

Final version received March 21, 2009

JÚLIUS KORBAŠ

DEPARTMENT OF ALGEBRA, GEOMETRY, AND MATHEMATICAL EDUCATION
FACULTY OF MATHEMATICS, PHYSICS, AND INFORMATICS
COMENIUS UNIVERSITY, MLYNSKÁ DOLINA
SK-842 48 BRATISLAVA 4
SLOVAKIA

OR

MATHEMATICAL INSTITUTE, SLOVAK ACADEMY OF SCIENCES
ŠTEFÁNIKOVA 49
SK-814 73 BRATISLAVA 1
SLOVAKIA
korbas@fmph.uniba.sk

PETER ZVENGROWSKI

DEPARTMENT OF MATHEMATICS AND STATISTICS,
THE UNIVERSITY OF CALGARY
CALGARY ALBERTA T2N 1N4
CANADA
zvengrow@ucalgary.ca

REFERENCES

- [1] J. F. ADAMS, *Vector fields on spheres*, Ann. of Math. **75** (1962), 603–632.
- [2] J. F. ADAMS, *Infinite Loop Spaces*, Princeton Univ. Press, Princeton, N. J. 1978.
- [3] D. AJAYI, S. ILORI, *Stiefel-Whitney classes of the flag manifold $\mathbb{R}F(1, 1, n - 2)$* , Czechoslovak Math. J. **52** (2002), 17–21.
- [4] E. ANTONIANO, *La acción del álgebra de Steenrod sobre las variedades de Stiefel proyectivas*, Bol. Soc. Mat. Mexicana (2) **22** (1977), 41–47.
- [5] E. ANTONIANO, S. GITLER, J. UCCI, P. ZVENGROWSKI, *On the K -theory and parallelizability of projective Stiefel manifolds*, Bol. Soc. Mat. Mexicana (2) **31** (1986), 29–46.
- [6] N. BARUFATTI, D. HACON, *K -theory of projective Stiefel manifolds*, Trans. Amer. Math. Soc. **352** (2000), 3189–3209.
- [7] N. BARUFATTI, D. HACON, K. Y. LAM, P. SANKARAN, P. ZVENGROWSKI, *The order of real line bundles*, Bol. Soc. Mat. Mexicana (3) **10** (2004), 149–158.
- [8] P. BAUM, W. BROWDER, *The cohomology of quotients of classical groups*, Topology **3** (1965), 305–336.
- [9] A. BOREL, *Sur l'homologie et la cohomologie des groupes de Lie compacts connexes*, Amer. J. Math. **76** (1954), 273–342.
- [10] G. BREDON, A. KOSINSKI, *Vector fields on π -manifolds*, Ann. of Math. **84** (1966), 86–90.
- [11] S. GITLER, D. HANDEL, *The projective Stiefel manifolds - I*, Topology **7** (1968), 39–46.
- [12] S. ILORI, D. AJAYI, *Vector fields on the real flag manifolds $\mathbb{R}F(1, 1, n - 2)$* , Math. Slovaca **58** (2008), 127–129.
- [13] I. M. JAMES, *The Topology of Stiefel Manifolds*, Cambridge University Press, Cambridge 1976.
- [14] I. JAMES, E. THOMAS, *An approach to the enumeration problem for non-stable vector bundles*, J. Math. Mech. **14** (1965), 485–506.
- [15] J. KORBAŠ, *On the vector field problem for $O(n)/O(1) \times O(1) \times O(n - 2)$* , Acta Math. Hungarica **105** (2004), 123–131.
- [16] J. KORBAŠ, *Distributions, vector distributions, and immersions of manifolds in Euclidean spaces*, Chapter 13 (pp. 665-724) in: Handbook of Global Analysis (edited by D. Krupka and D. Saunders), Elsevier, Amsterdam 2008.
- [17] J. KORBAŠ, P. SANKARAN, P. ZVENGROWSKI, *Span of projective Stiefel manifolds*, Preprint, Univ. of Calgary Yellow Series 704 (1991).
- [18] J. KORBAŠ, P. ZVENGROWSKI, *The vector field problem: a survey with emphasis on specific manifolds*, Exposition. Math. **12** (1994), 3–30.

- [19] J. KORBAŠ, P. ZVENGROWSKI, *On sectioning tangent bundles and other vector bundles*, Proc. Winter School Geometry and Physics, Srní (Czech Republic) 1994, Rend. Circ. Mat. Palermo (II), Supplemento **39** (1996), 85–104.
- [20] U. KOSCHORKE, *Vector Fields and Other Vector Bundle Morphisms - A Singularity Approach*, Lecture Notes in Math. **847**, Springer-Verlag, Berlin 1981.
- [21] K. Y. LAM, *Sectioning vector bundles over real projective space*, Quart. J. Math. Oxford (2) **23** (1972), 97–106.
- [22] K. Y. LAM, *A formula for the tangent bundle of flag manifolds and related manifolds*, Trans. Amer. Math. Soc. **213** (1975), 305–314.
- [23] K. Y. LAM, *Topological methods in the study of bilinear forms*, Perspectives in Geometry and Topology, Proc. of the Ind. Inst. Tech, Bombay Golden Jubilee International Workshop/Conference in Geometry and Topology, to appear.
- [24] K. Y. LAM, P. Y. H. YIU, *Sums of squares formulae near the Hurwitz-Radon range*, Contemp. Math. **58** part II (1987), 51–56.
- [25] K. Y. LAM, D. RANDALL, *Geometric dimension of bundles on real projective spaces*, Contemp. Math. **188** (1995), 137–160.
- [26] K. Y. LAM, D. RANDALL, *Periodicity of Geometric Dimension for Real Projective Spaces*, Progress in Mathematics, **136** (1996), 223–234.
- [27] G. MORENO, *The zero-divisors of the Cayley-Dickson algebras over the real numbers*, Bol. Soc. Mat. Mex. (3) **4** (1998), 13–27.
- [28] R. MOSHER, M. TANGORA, *Cohomology Operations and Applications in Homotopy Theory*, Harper & Row, Publishers, New York 1968.
- [29] O. SAEKI, *Notes on the topology of folds*, J. Math. Soc. Japan **44** (1992), 551–566.
- [30] O. SAEKI, *Fold maps on 4-manifolds*, Comment. Math. Helvetici **78** (2003), 627–647.
- [31] P. SANKARAN, P. ZVENGROWSKI, *Upper bounds for the span of projective Stiefel manifolds*, Recent developments in algebraic topology, 173–181, Contemp. Math. **407**, Amer. Math. Soc., Providence, RI, 2006.
- [32] L. SMITH, *Some remarks on projective Stiefel manifolds, immersions of projective spaces and spheres*, Proc. Amer. Math. Soc. **80** (1980), 663–669.
- [33] W. SUTHERLAND, *The Browder-Dupont invariant*, Proc. London Math. Soc. (3) **33** (1976), 94–112.
- [34] E. THOMAS, *Vector fields on manifolds*, Bull. Amer. Math. Soc. **75** (1969), 643–683.
- [35] K. YAMAGUCHI, *Spaces of free loops on real projective spaces*, Kyushu J. Math. **59** (2005), 145–153.
- [36] K. YAMAGUCHI, *The homotopy of spaces of maps between real projective spaces*, J. Math. Soc. Japan **58** (2006), 1163–1184.
- [37] P. ZVENGROWSKI, *Canonical vector fields on spheres*, Comment. Math. Helvetici **43** (1968), 341–347.
- [38] P. ZVENGROWSKI, *Über die Parallelisierbarkeit von Stiefel Mannigfaltigkeiten*, Preprint, Forschungsinst. für Math. Zürich (1976).
- [39] P. ZVENGROWSKI, *Remarks on the span of $X_{n,r}$* , XI Brazilian Topology Meeting (Rio Claro 1998), 85–98, World Sci. Publishing, River Edge, NJ 2000.